

Sept.

25 Cents

# Science and Invention

IN PICTURES

FLAME THROWER  
PROTECTS EXPLORERS

See Page 446

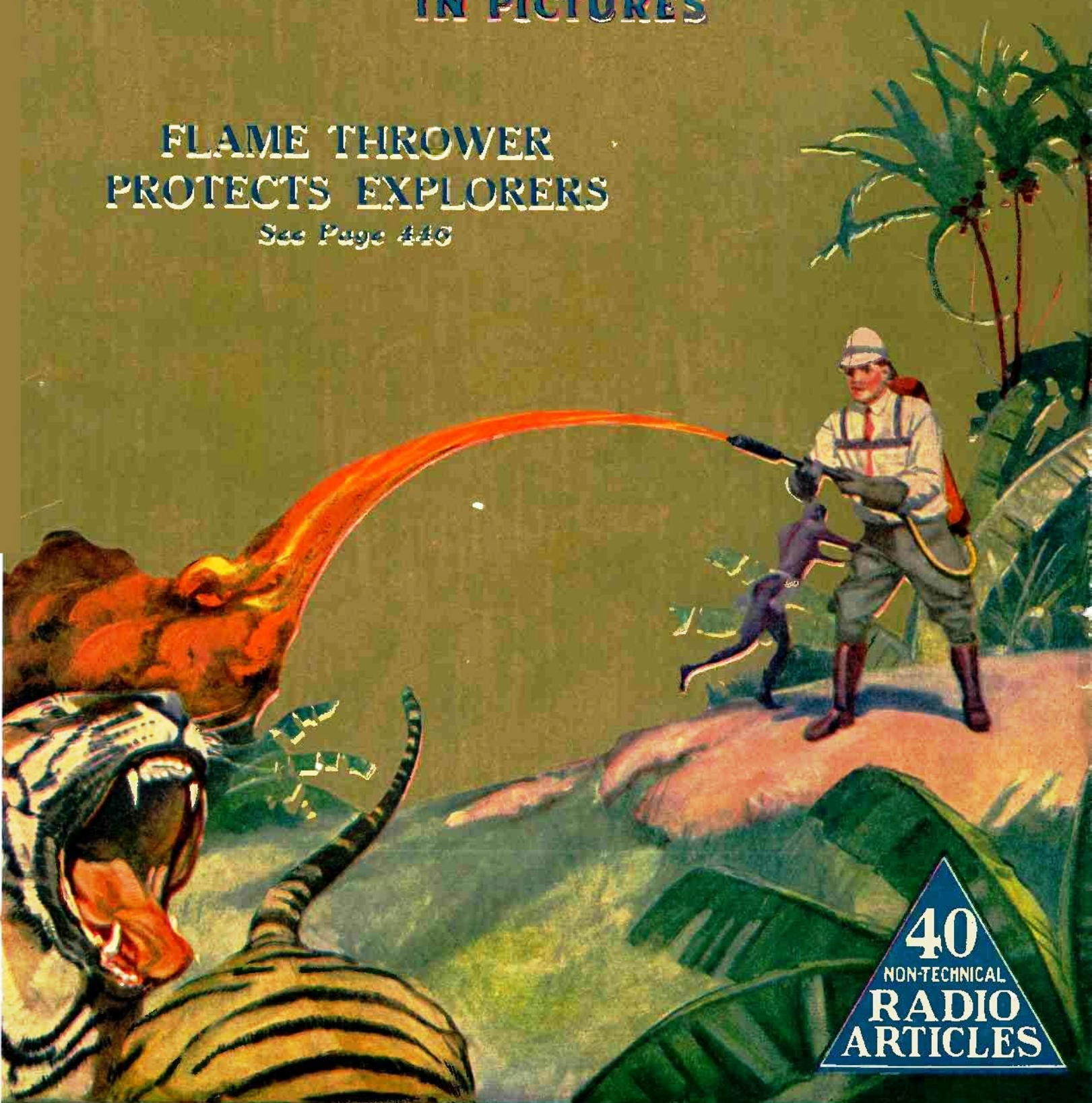

40  
NON-TECHNICAL  
RADIO  
ARTICLES

# I Can Qualify You as a Radio Expert in a Few Months!

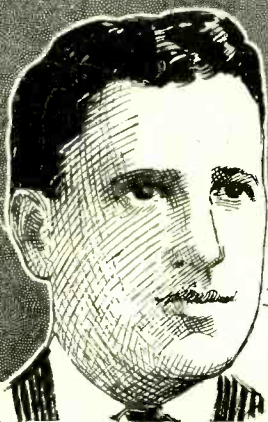

## Learn at Home Earn \$2500 to \$10,000 a Year

**E. R. HAAS**  
Director, National  
Radio Institute.

Merle Wetzal, one of my students, reports that he is now making *three times* what he did before becoming a radio expert. Emmett Welch writes that after finishing my training, he made \$300 a month and all expenses. George Jones says: "To your course I credit my present position as manager of this Radio Department." Another graduate is now an operator of a broadcasting station, PWX of Havana, Cuba, and earns \$250 a month.

Still another graduate, only 16 years old, is averaging \$70 a week in a radio store. Hundreds of other former students enthusiastically tell of their successes as radio experts! The field of Radio today is a real treasure house of wonderful opportunities. It offers rewards beyond your fondest dreams! Mail coupon today for my Free Book just out—which explains in detail the amazing opportunities in this World's Fastest-Growing Industry.

## Hundreds of Big Paying Positions Waiting

Do you want to earn far more money than you ever dreamed possible? Do you want to be your own boss?—to have a profitable business of your own? Do you want to travel the whole world over—and make big money while doing so?

Radio offers you all of these opportunities—and more! Radio, the new infant industry; Radio, growing with leaps and bounds; Radio, the field of endeavor with the most promising future of all!

Hardly a week goes by without our receiving urgent calls for our graduates. "We need the services of a competent Radio Engineer"—"We want men with executive ability in addition to radio knowledge to become our local managers"—"We require the services of several resident demonstrators"—these are just a few small indications of the great variety of opportunities open to our graduates.

### This Wonderful FREE BOOK Has Shown Thousands The Way To Bigger Money

This Free Book has opened the eyes of thousands to the glorious opportunities in Radio. Never in all history has an industry jumped into prominence so rapidly! Millions of dollars now spent yearly on Radio. Hundreds of big money positions have been created almost overnight. Thousands of men trained in Radio are needed. If you are ambitious—if you are looking for a field which offers *big money, fascinating work, advancement, and a real future*, send for this Free Book. It costs you nothing. You obligate yourself in no way. Yet this book can easily mean all the difference between the work you are doing now and wonderful success! Before you forget—mail the coupon NOW!

**NATIONAL  
RADIO  
INSTITUTE**

Dept. 14-JA  
Washington, D.C.



**E. R. HASS,**  
NATIONAL RADIO INSTITUTE,  
Dept. 14-JA, Washington, D. C.

Without obligation on my part, please send me the free book "Rich Rewards in Radio," with full details as to how I can quickly train for the position of "Certified Radiotician" in my spare hours at home. Also tell me how your free Employment Service will help me secure a good paying position, and about your special short-time offer. Please write plainly.

Name ..... Age.....  
Street ..... Occupation.....  
City..... State.....



**Pay Increases  
Over \$100 a month**  
I am averaging anywhere from \$75 to \$150 a month more than I was making before enrolling with you. I would not consider \$10,000 too much for the course.  
(signed) A. N. Long,  
120 No. Main St.,  
Greensburg, Pa.

**Doubles Salary**

I can very easily make double the amount of money now than before I enrolled with you. Your course has benefited me approximately \$3,000 over and above what I would have earned had I not taken it.

T. Winder,  
731 Belford Ave.,  
Grand Junction, Colo.



**From \$15 to \$80 a Week**  
Before I enrolled with you I was making \$15 a week on a farm. Now I earn from \$2,080 to \$4,420 a year, and the work is a hundred times easier than before. Since graduating a little over a year ago, I have earned almost \$4,000 and I believe the course will be worth at least \$100,000 to me.  
(signed)  
Geo. A. Adams,  
Route 1, Box 10,  
Tamaqua, Pa.



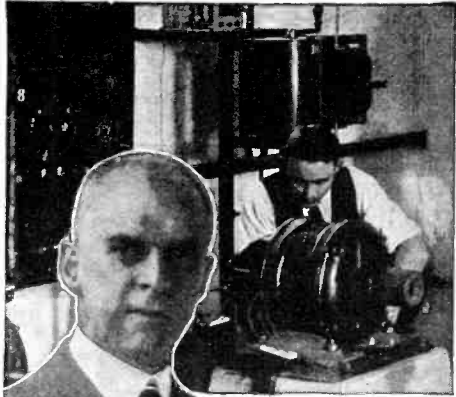

Herbert Dickerson, Warrenton, Va., makes \$7,500 a year



Automotive Electricity pays W. E. Pence, Albany, Oregon, over \$9,000 a year

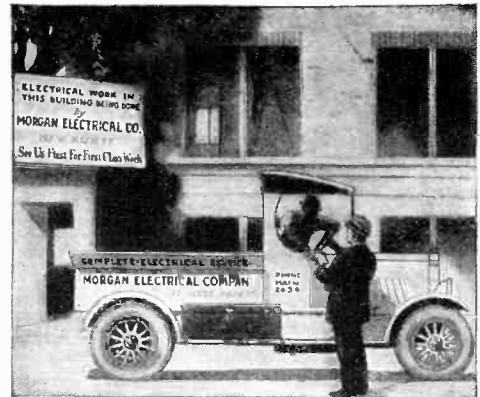

J. R. Morgan, Columbus, Ohio, makes \$30 to \$50 a day in business for himself



# Electrical Experts Are in Big Demand I Will Train You at Home To Fill a Big Pay Job

## Electricity — the World's Big Pay Field

Electricity is the field of the greatest opportunities. In all other trades and professions competition is so keen from over-crowding that only the exceptional man can get to the top.

Not so in the Electrical line.

Here is a profession that is fairly bubbling with possibilities — with thousands of chances for wonderful success. We stand today on the very threshold of the real Electrical Age—an Age when everything now operated by steam or gas or horses, will be moved by Electricity. But it is an Age demanding specialists—trained men—Electrical Experts. Such men can easily earn from \$12 to \$30 a day.

Money is being poured into the Electrical Industry at the rate of a billion dollars a year. Think of it—a thousand million dollars a year for electrical expansion. This means—men—jobs—opportunities.

My big book the "Vital Facts" of the electrical industry and the wonderful opportunities that await "Cooke Trained Men" tells you all about this Big Pay Field.

**Mail Coupon for the Free Vital FACTS**

It's a shame for you to earn \$15 or \$20 or \$30 a week, when in the same six days as an Electrical Expert you can make \$70 to \$200 a week—and do it easier—not work half so hard. Why then remain in the small-pay game, in a line of work that offers no chance, no big promotion, no big income? Fit yourself for a real job in the great electrical industry. I'll show you how.

## Be an Electrical Expert Earn \$3,500 to \$10,000 a Year

Today even the ordinary Electrician—the "screw driver" kind—is making money—big money. But it's the trained man—the man who knows the whys and wherefores of Electricity—the "Electrical Expert"—who is picked out to "boss" the ordinary Electricians—to boss the Big Jobs—the jobs that pay \$3,500 to \$10,000 a Year. Get in line for one of these "Big Jobs" by enrolling now for my easily learned, quickly grasped, right-up-to-the-minute, Spare-Time Home-Study Course in Practical Electricity.

### Age or Lack of Experience No Drawback

You don't have to be a College Man; you don't have to be a High School Graduate. As Chief Engineer of the Chicago Engineering Works, I know exactly the kind of training you need, and I will give you that training. My Course in Electricity is the most simple, thorough and successful in existence, and offers every man, regardless of age, education, or previous experience, the chance to become, in a very short time, an "Electrical Expert," able to make from \$70 to \$200 a week.

### FREE Electrical Working Outfit FREE

With me, you do practical work—at home. You start right in after your first few lessons to work at your profession in the regular way. For this you need tools, and I give them to you absolutely free—a whole kit, a complete outfit, one that would cost you \$12 to \$15.

### Your Satisfaction Guaranteed

So sure am I that you can learn Electricity—so sure am I that after studying with me, you, too, can get into the "big money" class in electrical work, that I will guarantee under bond to return every single penny paid me in tuition, if, when you have finished my Course, you are not satisfied it was the best investment you ever made.

### Guarantee Backed by a Million Dollar Institution

Back of me in my guarantee, stands the Chicago Engineering Works, Inc., a million dollar institution, thus assuring to every student enrolled, not only a wonderful training in Electricity, but an unsurpassed Student Service as well.

It's this Service that makes "Cooke" training different from any other training. It's this Service, plus "Cooke" Training, that makes the "Cooke" Trained Man the "Big-Pay Man," everywhere.

Be a "Cooke" Trained Man and earn \$12 to \$30 a day—\$70 to \$200 a week—\$3,500 to \$10,000 a year.

### Get Started Now—Mail Coupon

I want to send you my Electrical Book and Proof Lessons both Free. These cost you nothing and you'll enjoy them. Make the start today for a bright future in Electricity. Send in Coupon—NOW.

L. L. Cooke, Chief Engineer

**Chicago Engineering Works**  
2150 Lawrence Ave., Dept. 26 Chicago

### Use this Free Outfit Coupon!

L. L. COOKE, The Man Who Makes "Big-Pay" Men  
Dept. 26  
2150 Lawrence Ave., Chicago

Dear Sir: Send at once, Sample Lessons, your Big Book, and full particulars of your Free Outfit and Home Study Course, also the Free Radio Course—all fully prepaid without obligation on my part.

Name .....

Address .....

Occupation .....

**The "Cooke" Trained Man is the "Big Pay" Man**

# Science and Invention

FORMERLY  
**ELECTRICAL EXPERIMENTER**

Member Audit Bureau of Circulations

EDITORIAL & GENERAL OFFICES: 53 Park Place, New York City  
Published by Experimenter Publishing Company, Inc. (H. Gernsback, Pres.; S. Gernsback, Treas.; R. W. DeMott, Sec'y).  
Publishers of SCIENCE AND INVENTION, RADIO NEWS, PRACTICAL ELECTRICS and MOTOR CAMPER & TOURIST.

## Table of Contents for September

POPULAR SCIENTIFIC ARTICLES		AUTOMOBILES		
EDITORIAL	By H. Gernsback	445	CIGAR LIGHTER AND HELP FOR AUTOISTS	453
FLAME THROWER IN AFRICAN JUNGLES	By J. G. Frederick	446	SOLVING TRAFFIC PROBLEM	455
ELECTRICITY FROM THE WIND	By C. A. Oldroyd	447	ODD USES FOR TRACTORS	468
WHAT CAUSES THE AURORA BOREALIS?	By Donald H. Menzel, Ph.D.	448	NEW AUTO SHOCK ABSORBER	468
CAN PANAMA CANAL BE DEFENDED?	By Graser Schornstheimer, Staff Naval Editor	449	PNEUMATIC WHEEL	469
THE FLY—ITS EXTERMINATION	By Dr. Ernest Bade	450	<b>ELECTRICITY</b>	
WIDELY DIVERSIFIED APPLICATIONS OF SCIENCE	By Dr. Ernest Bade	451	ELECTRICITY FROM THE WIND	By C. A. Oldroyd
FLYING OVER A VOLCANO	By Dr. Ernest Bade	452	WHAT CAUSES THE AURORA BOREALIS?	By Donald H. Menzel, Ph.D.
CIGAR LIGHTER AND HELP FOR AUTOISTS	By L. Fournier	453	CAN PANAMA CANAL BE DEFENDED?	By Graser Schornstheimer, Staff Naval Editor
BLOOD CIRCULATION SYSTEM MODELS	By Dr. Albert Neuburger	453	A SUPER-SENSITIVE MICROPHONE	By Ernest Keil
COLLAPSIBLE TOWER FOR LANDING DIRIGIBLE	By Lucien Fournier	454	VACUUM FINDS MANY USES	By H. Winfield Secor, E.E.
MIRROR DISTORTED MOVIES	By Ernest Keil	454	STOPPING PHONOGRAPH STOPS MOTOR	By C. A. Oldroyd
EUROPEAN ADVANCES IN SCIENCE	By Ernest Keil	455	ELECTRICITY—DESTROYER OF AIRSHIPS	By C. A. Oldroyd
SUPER-SENSITIVE MICROPHONE	By Ernest Keil	455	<b>RADIO ARTICLES</b>	
SOLVING TRAFFIC PROBLEM	By Ernest Keil	455	VACUUM FINDS MANY USES	By H. Winfield Secor, E.E.
ROCKET LIFE-LINE ANCHOR	By Ernest Keil	456	TELEGRAPH CIRCUIT RECEIVES RADIO	By H. Winfield Secor, E.E.
THE OYSTER'S BODY	By Ernest Keil	456	HOW RADIO DRAMA IS MADE	By H. Winfield Secor, E.E.
VACUUM FINDS MANY USES	By Ernest Keil	457	PHILADELPHIA'S RADIO ENTERTAINERS	By H. Winfield Secor, E.E.
THE MAN ON THE METEOR	By H. Winfield Secor, E.E.	458 and 459	THE MONTH'S RADIO NOVELTIES	By H. Winfield Secor, E.E.
(Ninth and final installment)	By H. Winfield Secor, E.E.	458 and 459	A RADIO KISS	By H. Winfield Secor, E.E.
DR. HACKENSAW'S SECRETS	By Ray Cummings	460	RECORD MAKING STATION	By H. Winfield Secor, E.E.
WONDERFUL ROMAN BATHS AND WATER SYSTEMS	By Clemente Fezandic	460	EUROPEAN RADIO APPARATUS	By H. Winfield Secor, E.E.
EVERYDAY CHEMISTRY	By Charles Beecher Bunnell	462	THE RITZ SUPER-NEUTRODYNE	By H. Winfield Secor, E.E.
GAME INCORPORATES DX THRILL	By Raymond B. Wailes	464	A THREE TUBE RECEIVER	By Leon L. Adelman
STOPPING PHONOGRAPH STOPS MOTOR	By Raymond B. Wailes	465	THE RADIO ORACLE	By W. L. Pearce
NEW JAZZ INSTRUMENT	By Alexander Kolbe	465	RADIO WRINKLES	By W. L. Pearce
ELECTRICITY—DESTROYER OF AIRSHIPS	By Alexander Kolbe	467	<b>CONSTRUCTOR ARTICLES</b>	
THE TELEMETER	By C. A. Oldroyd	467	CANVAS CANOE CONSTRUCTION	By Dr. Ernest Bade
ODD USES FOR TRACTORS	By Ernest Brennecke	468	USES FOR BROKEN TOOLS	By Dr. Ernest Bade
MAGIC FOR EVERYBODY	By Ernest Brennecke	471	USES FOR OLD SPOOLS	By T. B. Sage
MORE GAMBLERS' TRICKS EXPOSED	By Prof. Joseph Dunninger	472	HOSE KINK	By Walter Markowski
SCIENTIFIC PROBLEMS AND PUZZLES	By Mark Mellen	473	MICROSCOPIC DRAWING	By Walter Markowski
THIS MONTH'S NEW DEVICES	By Ernest K. Chapin	474	HAIRPIN SURGICAL INSTRUMENTS	By Walter Markowski
THE HEAVENS IN SEPTEMBER	By Ernest K. Chapin	475	HOW-TO-MAKE-IT DEPARTMENT	By W. C. Michel
READERS FORUM	By Ernest K. Chapin	476	WRINKLES, RECIPES AND FORMULAS	By W. C. Michel
SCIENCE ODDS AND ENDS	By Ernest K. Chapin	477	<b>CHEMISTRY ARTICLES</b>	
AWARDS IN \$100.00 PHONOGRAPH NEEDLE CONTEST	By Ernest K. Chapin	478	FLAME THROWER IN AFRICAN JUNGLES	By Ernest Keil
HOW-TO-MAKE-IT DEPT.—\$30.00 IN PRIZES	By Ernest K. Chapin	483	EUROPEAN ADVANCES IN SCIENCE	By Ernest Keil
SCIENTIFIC HUMOR—PRIZES FOR BEST JOKES	By Ernest K. Chapin	495	EVERYDAY CHEMISTRY	By Raymond B. Wailes
AWARDS IN \$1,000 MONTHLY CONTEST	By Ernest K. Chapin	498	SMOKERS' PARADISE	By Raymond B. Wailes
			WRINKLES, RECIPES AND FORMULAS	By W. C. Michel
			<b>ASTRONY ARTICLES</b>	
			WHAT CAUSES THE AURORA BOREALIS?	By C. A. Oldroyd
			THE HEAVENS IN SEPTEMBER	By Isabel M. Lewis, M.A.

HOW TO SUBSCRIBE FOR "SCIENCE AND INVENTION." Send your name, address and remittance to Experimenter Publishing Co., 53 Park Place, New York. Mention the name of the magazine you are ordering. We also publish RADIO NEWS, PRACTICAL ELECTRICS and MOTOR CAMPER & TOURIST.  
RATES AND TERMS. The subscription rate for SCIENCE AND INVENTION is \$2.50 per year (12 numbers). When remitting do so by check, money order or registered letter. If cash is enclosed, avoid sending cash through the mail if possible.

SCIENCE AND INVENTION is published on the 25th of each month. There are 12 numbers per year. Subscription price is \$2.50 a year in U. S. and possessions. Canada and foreign countries \$3.00 a year. U. S. coin as well as U. S. stamps accepted (no foreign coin or stamps). Single copies, 25 cents each. A sample copy will be sent gratis on request. Checks and money orders should be drawn to order of EXPERIMENTER PUBLISHING CO., Inc. If you change your address notify us promptly, in order that copies are not misdirected or lost.

New York City  
General Advertising Dept.  
53 Park Place

Western Advertising Representatives  
Finucan & McClure  
720 Cass St., Chicago, Ill.

Pacific Coast Advertising Representatives  
A. J. Norris Hill Co.  
Hearst Bldg., San Francisco, Calif.

Kansas City Advertising Representatives  
George F. Dillon  
Republic Building, Kansas City, Mo.

possible. Subscriptions for less than one year are not accepted. Subscriptions may be made in combination with RADIO NEWS, PRACTICAL ELECTRICS or MOTOR CAMPER & TOURIST with considerable saving. Send postal for special rates. Subscriptions start with the current issue, unless otherwise ordered.  
POSTAGE. We prepay postage in all parts of the United States, Mexico and island possessions. For foreign or Canadian subscriptions we require 50 cents in addition to the subscription price for additional postage charges.

All communications and contributions to this journal should be addressed to Editor, SCIENCE AND INVENTION, 53 Park Place, New York City, N. Y. Unaccepted contributions cannot be returned unless full postage has been included. ALL accepted contributions are paid for on publication. A special rate is paid for novel experiments; good photographs accompanying them are highly desirable.  
SCIENCE AND INVENTION, Monthly. Application as second class matter made at New York, N. Y., with additional entry at Long Island City, N. Y. Post

CHANGE OF ADDRESS. Notify us as far in advance as possible. It requires several weeks to make an address change on our records. Always write clearly, giving your old address as well as your new. ON EXPIRATION of your subscription we enclose a renewal blank in our last number to you and notify you otherwise. Unless we receive your order for a renewal, with your remittance, we stop our delivery to you on expiration.  
COMMUNICATION to us should always bear your full name, address and when possible the number which appears on your wrapper every month.

Office, under act of Congress of March 3, 1879, formerly entered at Jamaica, N. Y. Title Registered at the Patent Office. Copyright, 1924, by E. P. Co., Inc., New York. The Contents of this Magazine are copyrighted and must not be reproduced without giving full credit to the publication.

SCIENCE AND INVENTION is for sale at all newsstands in the United States and Canada; also at Brentano's, 37 Avenue de l'Opera, Paris. Member of the Audit Bureau of Circulations.

# How the LaSalle Problem Method Bridges the Salary-Gap



—Why in three months' time alone as many as 1,193 LaSalle members reported definite salary-increases totalling \$1,248,526, an average increase per man of 89 per cent!

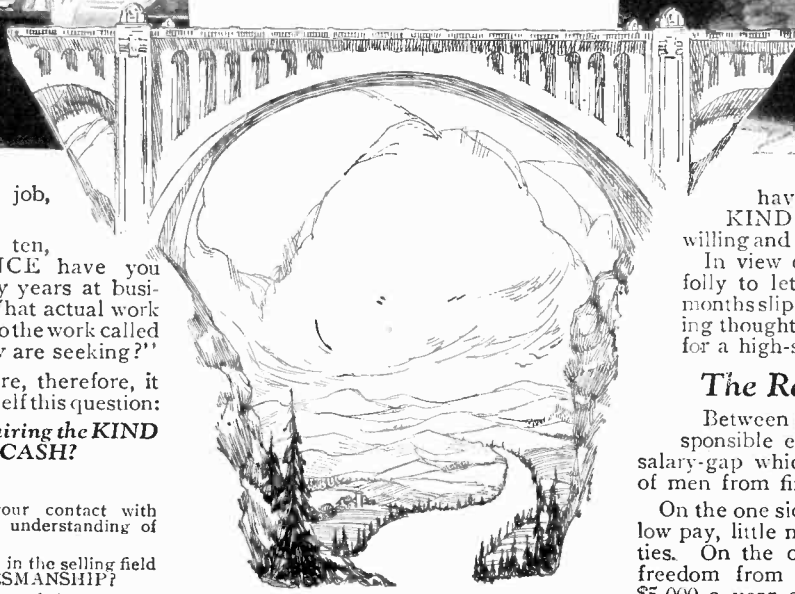

When you apply for a job, what is the first question?

Why, nine times out of ten, it's "What EXPERIENCE have you had?" —Not "How many years at business," understand, but "What actual work have you performed similar to the work called for by the position you now are seeking?"

For the sake of your future, therefore, it will pay you well to ask yourself this question:

**How rapidly are you acquiring the KIND of experience that you can CASH?**

For instance—

Are you depending upon your contact with the head bookkeeper for your understanding of ACCOUNTANCY?

—Upon hit-or-miss experience in the selling field for your understanding of SALESMANSHIP?

—Upon the routine transactions of the shipping department for your understanding of TRAFFIC MANAGEMENT?

—Upon the occasional discussion of isolated contracts for your understanding of LAW?

—Upon your lunch-time chats with representatives of investment houses for your understanding of FINANCE?

Don't think, for a moment, that you can DODGE the facts which govern salary by saying that other men have come up from the ranks thru day-to-day experience alone. They have—but—business moves at a far swifter pace than it moved even ten years ago. The great demand is for youth and energy trained in the how and why.

Obviously, then, you cannot escape the following arresting challenge:

**How—in the shortest possible time—can you PLUS your day-to-day experience with a practical working knowledge of the BEST ways for performing the special tasks of the higher positions?**

During the past fourteen years more than 450,000 men have faced that question squarely—and have found their answer in the LASALLE PROBLEM METHOD.

\* \* \*

When thousands and thousands of men in the United States and Canada (not to mention many hundreds in England, Australia, China and other foreign countries) choose the LaSalle Problem Method to speed their progress—when within only three months' time as many as 1,193 LaSalle members report definite salary-increases totalling \$1,248,526—when the average increase so reported is 89 per cent—surely the LaSalle Problem Method must offer an

unusually sound way of securing quickly the KIND of experience that can be CASHED.

It does. —And here is WHY:

## You Learn By Doing

Suppose it were your privilege every day to sit in conference with the head of your firm. Suppose every day he were to lay before you in systematic order the various problems he is compelled to solve, and were to explain to you the principles by which he solves them. Suppose that one by one you were to WORK THOSE PROBLEMS OUT—returning to him every day for counsel and assistance—

Granted that privilege, surely your advancement would be faster—BY FAR—than that of the man who is compelled to pick up experience hit-or-miss.

Under the LaSalle Problem Method you pursue, to all intents and purposes, that identical plan. You advance by SOLVING PROBLEMS.

Only—instead of having at your command the counsel of a single individual—your Chief—you have back of you the organized experience of the largest business training institution in the world, the authoritative findings of scores of able specialists, the actual procedure of the most successful business houses in America.

Thus—instead of fumbling and blundering and maybe losing a job now and then, you are COACHED in the solving of the very problems you must face in the higher positions. Step by step, you work them out for yourself—until, at the conclusion of your training in a given branch of business, you

have at your finger-tips the KIND of experience that men are willing and glad to pay real money for.

In view of that opportunity, is it not folly to let the days and weeks and months slip away from you, when by taking thought you can put yourself in line for a high-salaried executive position?

## The Reward of Training

Between the routine job and the responsible executive position there is a salary-gap which is separating thousands of men from financial independence.

On the one side of the gap are long hours, low pay, little more than the bare necessities. On the other side are comparative freedom from supervision, an income of \$5,000 a year or better, the comforts and luxuries of life.

The only routes that can take a man across the gap are all of them marked "EXPERIENCE"—and of all those routes the only one that BRIDGES the gap is—HOME-STUDY TRAINING.

If you are intent to save the years you otherwise would waste, you cannot afford to turn away from that bridge—you cannot, indeed, afford even to turn this page—until you have taken the necessary steps to FIND the bridge and USE it!

The coupon just below this text will bring you a fascinating book—the story of how one man took this shorter route to success and earned for himself "Ten Years' Promotion in One." "Get this book," said a prominent Chicago executive, "even if you have to pay five dollars for it." LaSalle will send it to you FREE. With this book LaSalle will send you also complete information regarding the training you are interested in, together with details of its convenient payment plan.

Take your first real step toward that better position by placing the coupon in the mail TODAY.

**LaSalle Extension University**  
The Largest Business Training Institution in the World  
Dept. 9384-R Chicago, Illinois

Upon request, the book "Ten Years' Promotion in One," and material completely descriptive of the course and service that interests you, will gladly be sent without cost or obligation. Indicate your choice by checking, and write below your name and address.

- |   |  |
|---|--|
| <input type="checkbox"/> Business Management        | <input type="checkbox"/> Modern Business Correspondence and Practice |
| <input type="checkbox"/> Traffic Management         | <input type="checkbox"/> Modern Foremanship and Production Methods   |
| <input type="checkbox"/> Higher Accountancy         | <input type="checkbox"/> Personnel and Employment Management         |
| <input type="checkbox"/> Modern Salesmanship        | <input type="checkbox"/> Expert Bookkeeping                          |
| <input type="checkbox"/> Railway Station Management | <input type="checkbox"/> Business English                            |
| <input type="checkbox"/> Law—Degree of LL. B.       | <input type="checkbox"/> Commercial Spanish                          |
| <input type="checkbox"/> Commercial Law             | <input type="checkbox"/> Effective Speaking                          |
| <input type="checkbox"/> Industrial Management      | <input type="checkbox"/> C. P. A. Coaching                           |
| <input type="checkbox"/> Efficiency                 |  |
| <input type="checkbox"/> Banking and Finance        |  |

Name .....

Present Position .....

Address .....

Watch for  
These  
Departments  
in the  
**MOTOR  
CAMPER &  
TOURIST**

**THE OPEN ROAD**

One of the most valuable departments in this magazine is "THE OPEN ROAD." Each month, in this department, are shown different important highways and routes in the United States in map form so that in a short time anyone can become familiar with the best highways in the country.

**CAMPSITES**

This department is for the man who wants to camp in the outdoors on his motor trip. It shows the number and location of campsites in every state in the Union.

**PARKS**

One of the most desirable features of touring in America is the prevalence of wonderful, scenic parks, especially the great National Parks. There is a special department for these places.

**RADIO IN CAMP**

This is an unusual department for the man who is interested in Radio as a pleasant adjunct to the motor trip. It is compiled by a staff of the foremost Radio Experts in America.

**ROADSIDE REPAIRS**

Every autoist will welcome this department as a friend in need when the car breaks down on the road. Every line in it is of value to every motorist.

**AROUND THE CAMP-FIRE**

New and interesting things that come up from day to day and are of value to the motor traveller are in this department. It is a section of the book in which the reader always feels a personal interest.

**NEW ACCESSORIES**

A department for the Motor Car in which every new and worthy accessory of value to the Motor Camper and Tourist is detailed.

Then there are many feature articles written by men who have travelled everywhere in America. They tell of their trips and experiences and give many valuable hints on what to take on a trip, what to look out for and how to get the utmost in pleasure from the trip.



The Greatest Sport in the World  
**SEEING AMERICA**  
In Your Car

You don't know what you are missing. The idea this summer is to take that vacation of yours in your car. Don't leave it in the garage. Save hotel bills and all those heavy travelling expenses by taking your car with you.

And don't forget those happy week-ends in your own state—let the car take you.

MOTOR CAMPER & TOURIST, the Motor Tourist's magazine, tells you where you can go, how to make the trip at a minimum expense, what roads to travel and what to see on the trip.

MOTOR CAMPER & TOURIST is edited by H. Gernsback, Editor of Radio News, Science and Invention, and Practical Electrics.

Get the new idea—see America in your car!

the New Magazine  
**ON ALL NEWSSTANDS**  
**25c**

Subscriptions: \$2.50 the year. Foreign 50c extra.

**MOTOR  
CAMPER &  
TOURIST**

GERMOTT PUBLISHING CO.

*Incorporated*

33 Park Place New York City

*Owners*

Licensed Publishers—Experimenter Publishing Co.; also Publishers of RADIO NEWS, SCIENCE AND INVENTION and PRACTICAL ELECTRICS.



# I Guarantee to fit You for \$5000 ELECTRICAL JOBS or It Doesn't Cost You One Cent

As Chief Engineer of the famous S & H Electrical Works I know exactly what you need to make you a high-class, electrical expert, capable of earning from \$65 to \$200 a week. I will fit you at home, in a few weeks, for the big-money jobs. Experience unnecessary. S & H Employment Service free. Also unlimited advisory service—long after you have finished training for the high electrical jobs, and your own profitable business. S & H is backed by the Lincoln Institute of Technology.

**FREE PROOF** *That You Can Step Into These Electrical Jobs Quick This Amazing New Way*

**W**HY take chances? You want to step quickly into the big-money field of electricity, where there are countless opportunities. Naturally you want only the latest approved method of home training—the method endorsed by leading electrical experts. The method that doesn't hesitate to guarantee its promise to you.

As chief engineer of the S & H Engineering Co., I studied years upon the problem of making it possible for ambitious men who like electrical work to get the big-pay jobs without technical school or college education. I knew that every day the tragic shortage of technical experts hampered electrical progress. At last I discovered and copyrighted this remarkable Shop Type training in electricity, the biggest advance in 20 years in teaching electricity.

### No Experience Needed

And now any man of average intelligence can step into these big-pay jobs. In your own home you can have the practical, actual shop type training. That's the secret of the amazing success of S & H graduates—I discovered how to apply practical training with the theory of electricity so that even men who have never finished grade school are graduating into salaries they never dreamed they could command. My great satisfaction is that I made it possible for men to step quickly into high positions of electricity—made long years of apprenticeship and small-pay toil in this great field unnecessary.

### I Ask Only Twenty Weeks

This training is so plain, so simple, that many of my students graduate and enter the

profession in only 20 weeks' time. And yet so thorough that S & H graduates are in constant demand because they are trained in every branch of electricity. No wonder electrical experts have hailed this common-sense, practical, result-proving training as a boon to the electrical profession—so sadly in need of well-trained men.

### A Legal Binding Guarantee

You can't afford to miss this chance to forsake small-pay work and start upon a career of certain big money. Remember, you have the absolute guarantee of the S & H Engineering Co., and the Lincoln Institute of Technology back of this training. Your diploma will be from the Lincoln Tech. If when you have finished the course you are not satisfied, every cent will be refunded. No questions asked. We can afford to make this guarantee because I know that what I have done for others I can do for you. You will find that this new method of training far surpasses any other you have ever heard about. It makes you a real electrical expert, with the Lincoln Institute of Technology back of you.

### Electrical Outfit Free

So that you can begin to earn while you are training—many of my students make far more than the cost of training after the first few lessons—you are entitled to my special offer of a complete outfit of electrical apparatus, instruments and appliances, FREE, IF YOU MAIL COUPON AT ONCE. Thus right at the start you have equipment for actual shop type training without a cent of cost. Here for the first time you have this remarkable offer, plus the privileges of the famous S & H Employment Service and Unlimited Advisory Service. And even that isn't all—I have still another amazing offer—Mail coupon today and I'll tell you about it. Don't delay.

**Wanted**

### Supervising Engineers

Supervising Engineers for large power plants and systems always are in demand and hold positions of influence and big pay. I fit you for these jobs.

### Superintendents

You can be quickly equipped to accept big positions as superintendents of municipal systems—every city, even towns and villages, have plants that need men constantly.

### Foremen

One-half of all the business in the United States is electrical—many battery stations and electrical plants choose the S & H Shop type trained man for foreman and superintending positions.

### Business of Your Own

And a business of your own—scores of my graduates have established themselves in business without capital—Unholz and Farina were common laborers when they wrote to me, now they head the prosperous U & F Electrical Company, Chicago. No profession in the world offers so many opportunities for a paying business of your own.

## S & H ENGINEERING CO.

Affiliated with Lincoln Institute of Technology

1422 W. Monroe St. Dept. L-2 Chicago, Ill.



**FREE**

Chief Engineer  
S & H Engineering Co.,  
1422 W. Monroe St., Dept. L-2  
Chicago, U. S. A.

Please send me full particulars of your training in practical electricity and details of your remarkable free offer to those who enroll now. I understand this is free and does not obligate me in any way.

Name .....  
Address .....  
City ..... State .....

# SCIENCE and INVENTION READERS' BUREAU

## Time and Postage Saver

**I**N every issue of SCIENCE and INVENTION you undoubtedly see numerous articles advertised about which you would like to have further information.

To sit down and write an individual letter to each of these respective concerns, regarding the article on which you desire information, would be quite a task.

As a special service to our readers, we will write the letters for you, thus saving your time and money.

Just write the names of the products about which you want information, and to avoid error the addresses of the manufacturers, on the coupon below and mail it to us.

If the advertiser requires any money or stamps to be sent to pay the mailing charges on his catalogue or descriptive literature, please be sure to enclose the correct amount with the coupon.

We will transmit to the various advertisers your request for information on their products.

This service will appear regularly every month on this same page in SCIENCE and INVENTION.

If there is any Manufacturer not advertising in this month's issue of SCIENCE and INVENTION from whom you would like to receive literature, write his name, address and the product in the special section of the coupon below.



TEAR ALONG THIS LINE

**READERS' SERVICE BUREAU,**  
Experimenter Publishing Co., Inc., 53 Park Place, New York, N. Y.

9-24

Please advise the firms listed below that I would like to receive detailed information on their product as advertised in the ..... issue of SCIENCE and INVENTION.

NAME	ADDRESS	List here specific article on which you wish literature.	If Catalogue of complete line is wanted, check in this column.
.....	.....	.....	.....
.....	.....	.....	.....
.....	.....	.....	.....
.....	.....	.....	.....
.....	.....	.....	.....
.....	.....	.....	.....
.....	.....	.....	.....
.....	.....	.....	.....
.....	.....	.....	.....
.....	.....	.....	.....

NOTE—This Form Should Not Be Used For Technical Questions.

If you desire any special information from a manufacturer whose advertisement does not appear in this month's issue, use this space.

.....  
.....  
.....

Your own name here.....

If you are a dealer check here.

Address.....

City.....

State.....



*Marshall* **The Greatest Advance yet made in**  
**RADIO**  
 3-4 and 5 Tube Sets

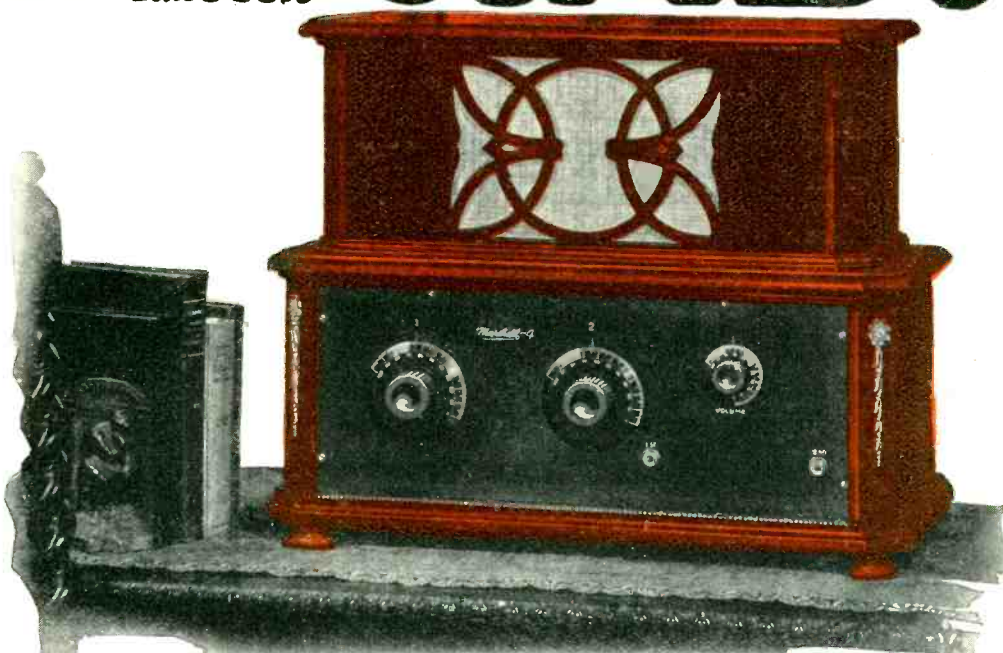

*Solid Mahogany Cabinet of unique and artistic design*

*Sold with or without the Loud Speaker Combination*

**This Beautiful Marshall 4 Tube Non-Oscillating Receiver** *only \$5.00 DOWN*  
*Complete with all accessories*

**WRITE TODAY** for full particulars of this most exceptional offer. Marshall Sets embody the very latest improvements known to radio. They are licensed under Pfanstiehl Patents Pending, and utilize the wonderfully efficient Pfanstiehl Non-Oscillating System. This discovery of Carl Pfanstiehl is the big sensation of the 1924-25 radio season. It brings the first real improvement over the Neutrodyne, Superhetrodyne, Regenerative, and Reflex circuits. It is positively non-regenerative. It brings to radio a new degree of musical quality. Its selectivity will delight the experienced radio operator. Yet it is so easy to tune that the novice will handle it like an expert.

**Easy Monthly Payments—2 Weeks Free Trial**

This is the remarkable offer we are prepared to make you! Two weeks to prove that the outfit you select is everything we have said for it. If it doesn't make good our claims, back it comes, and your deposit will be cheerfully refunded. But if it fulfills all your expectations, you may pay for it in easy monthly installments. You don't risk a cent when ordering from us. You *must* be satisfied, or we don't do business. Is it any wonder that radio buyers the country over are rushing to take advantage of such an offer? If YOU are interested, figure on getting your order in early, while prompt shipment can be made. Everyone predicts a serious shortage of radio supplies this season. Send for full particulars today.

**Beautiful Solid Mahogany Cabinets**

Just compare the beautiful outfit pictured above with the usual radio box and horn! The speaker cabinet appears as part of the combination unit. Designed by a master designer—fashioned of the finest solid mahogany, it will harmonize with the furnishings of the finest homes. Yet through our different way of merchandising, this exceptional cabinet value—plus the unequalled mechanical qualities of the Marshall Set—plus easy terms—costs you actually less money than the ordinary sets sell for on a cash basis.

**Complete Outfits If Desired**

In buying from Marshall, you have the choice of a set complete with all accessories, or the set alone. You have choice of dry cell or storage battery outfits. Unless you already own the accessories, you can buy them from us at less-than-market prices, with your set, on easy terms. Your outfit will come all ready to set up and operate within a few minutes,—saving time and trouble—and saving money, too.

**MARSHALL RADIO PRODUCTS, INC.**  
 Marshall Blvd. and 19th Street, Dept. 14-26, Chicago

**Send Coupon for Special Offer!**

If you have any idea of buying a radio set this year, don't let this chance slip by. Our terms and liberal guarantees have set a new pace in the radio business. The low prices we will make you on a 3, 4, or 5 tube Marshall set will surprise you. A letter, postcard, or just coupon will do. But send it today.

*We also have a most favorable offer for radio dealers. Write.*

**Marshall Radio Products, Inc.**  
 Marshall Blvd. and 19th St., Dept. 14-26, Chicago

Please send me your special offer price, terms and full description of Marshall Radio Outfits. Though I may change my mind on receiving your proposition, my preference now is for a:

.....3 Tube .....4 Tube .....5 Tube (Please check)

Name .....

Address .....

# Build Your New Receiver this Month

VIA

# “Consrad”

Your pick of Radio books, patterns or diagrams on more than 150 of the Practical Radio Receivers in use today, compiled by the foremost radio authorities in the country and every one authentic, complete and practical—also books and literature on the care and operation of every part of your Radio Set.



## Sold by All Reliable Radio Dealers

or write direct to

**The Consrad Co.**  
233 Fulton Street  
New York City

# Consrad

RADIO'S FOREMOST PUBLISHERS



# \$3 **And it's yours**

**DOWN**

## The Greatest Typewriter Bargain Ever Offered

Right now we are making you the greatest typewriter offer you ever dreamed of—an eye opener. This wonderful standard Shipman-Ward Rebuilt Underwood only \$3.00 down. Ten days' free trial and the easiest monthly payments, shipped direct to you from our big factory.

### Ten Days' Free Trial

Yes, only \$3.00 down puts this genuine late model Shipman-Ward Rebuilt Underwood in your home. You can try it, test it, and then decide. See for yourself how new it is, how it writes. You must be satisfied. Your \$3.00 unconditionally returned if at the end of ten days you are not satisfied. The entire transaction will not cost you one cent.

### Easy Monthly Payments

Little more than rental. Balance of payments so small you will hardly notice them, while you enjoy the use of this wonderful machine. You don't have to scrimp and save to pay cash. All at a big saving to you.

### Five Year Written Guarantee

With every typewriter we give a written guarantee. These machines are rebuilt like new by the famous SHIPMAN-WARD PROCESS. Equipped

with late improvements. You can't tell them from a new machine. The world's standard typewriter, the same models as sold by the Underwood Typewriter Company today, at a big saving to you. Act Now! Get this splendid offer and save money.

### Free Book of Facts

Write for this free book of facts explaining Shipman-Ward's wonderful system of rebuilding typewriters. We show you exactly how it's done. How you are able to buy them. Complete and valuable information about the typewriter industry, both instructive and educational.

**ACT NOW! Mail this coupon today.**

### Free with Every Typewriter

A complete course in touch typewriting. You don't have to know how to operate a typewriter. You can learn to operate this machine in one day. We also give free a waterproof cover and all tools that come with a typewriter.

### From Factory to You

These machines are shipped direct from our factory—the largest typewriter rebuilding plant in the world. They are rebuilt by the famous SHIPMAN-WARD PROCESS. Developed through 30 years in the typewriter business. Through our money saving methods of rebuilding and elimination of a large expensive sales force we are able to make this wonderful money saving offer to you. ACT TODAY, take advantage of it and you will save money.

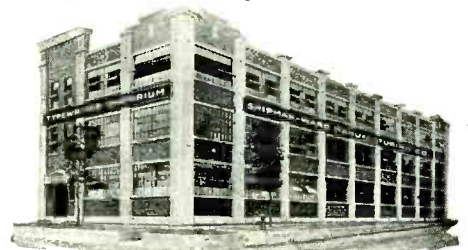

All Shipments made direct to you from our modern factory—the largest typewriter rebuilding plant in the world.

## FREE BOOK COUPON

**Shipman-Ward Mfg. Co.**  
2166 Shipman Bldg.

Montrose and Ravenswood Aves., Chicago

Send by return mail your wonderful offer of Shipman-Ward Standard Rebuilt Underwood, also your Free book of facts. (This is not an order and does not obligate me in any way.)

Name.....

Street or R. F. D. No.....

Post Office..... State.....

**SHIPMAN-WARD MFG. CO.**  
2166 Shipman Bldg., Chicago, Ill.      Montrose and Ravenswood Ave.

# Practical Electrics

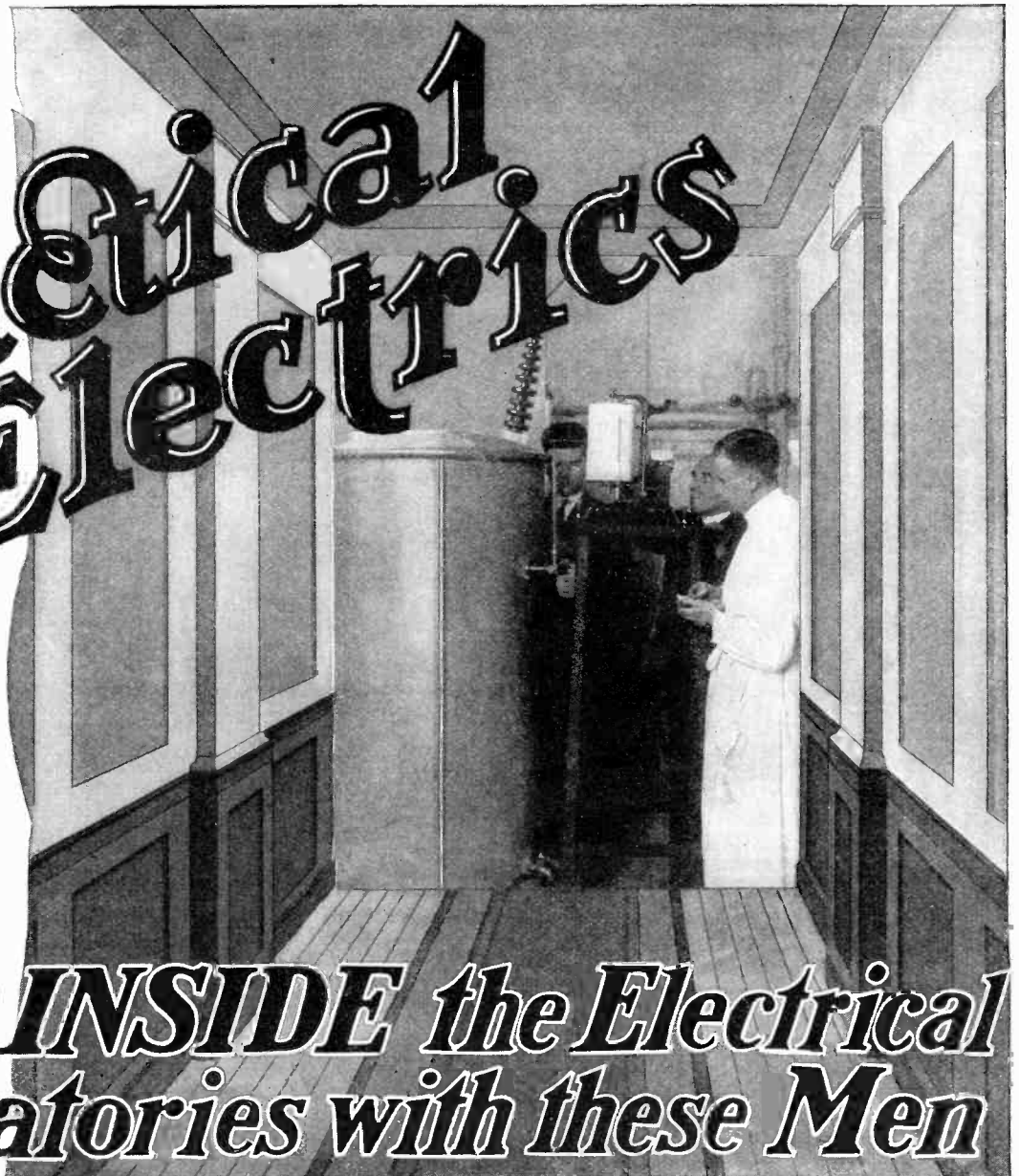

**STEP INSIDE the Electrical  
Laboratories with these Men**

The Electrical Engineers who spend days and months in the great research laboratories of America discover many marvelous uses for that modern Wizard, "ELECTRICITY."

PRACTICAL ELECTRICS is the only magazine, written for the layman, that brings these wonderful developments of the laboratories direct to you. PRACTICAL ELECTRICS takes you into the laboratories with these men as they develop step by step the new and interesting things in Electricity. Everything in PRACTICAL ELECTRICS is written so that you can understand it easily. It is profusely illustrated with pictures and drawings.

You can obtain PRACTICAL ELECTRICS on all newsstands for 25c the copy. Or fill out the coupon below and mail it to us with \$2.50 and we will have it delivered to your door for twelve months.

**Germott  
Publishing Co.**

*Incorporated*

33 Park Place  
New York City

*Owners*

Licensed Publishers — Experimenters  
Publishing Co., also

Publishers of

RADIO NEWS, SCIENCE AND INVENTION  
and MOTOR CAMPER AND TOURIST

GERMOTT PUBLISHING CO., INC.,  
53 PARK PLACE, N. Y. CITY

S.I.-9

Enclosed find \$2.50 for my subscription to PRACTICAL ELECTRICS for one year.

NAME .....

ADDRESS .....

CITY, STATE.....

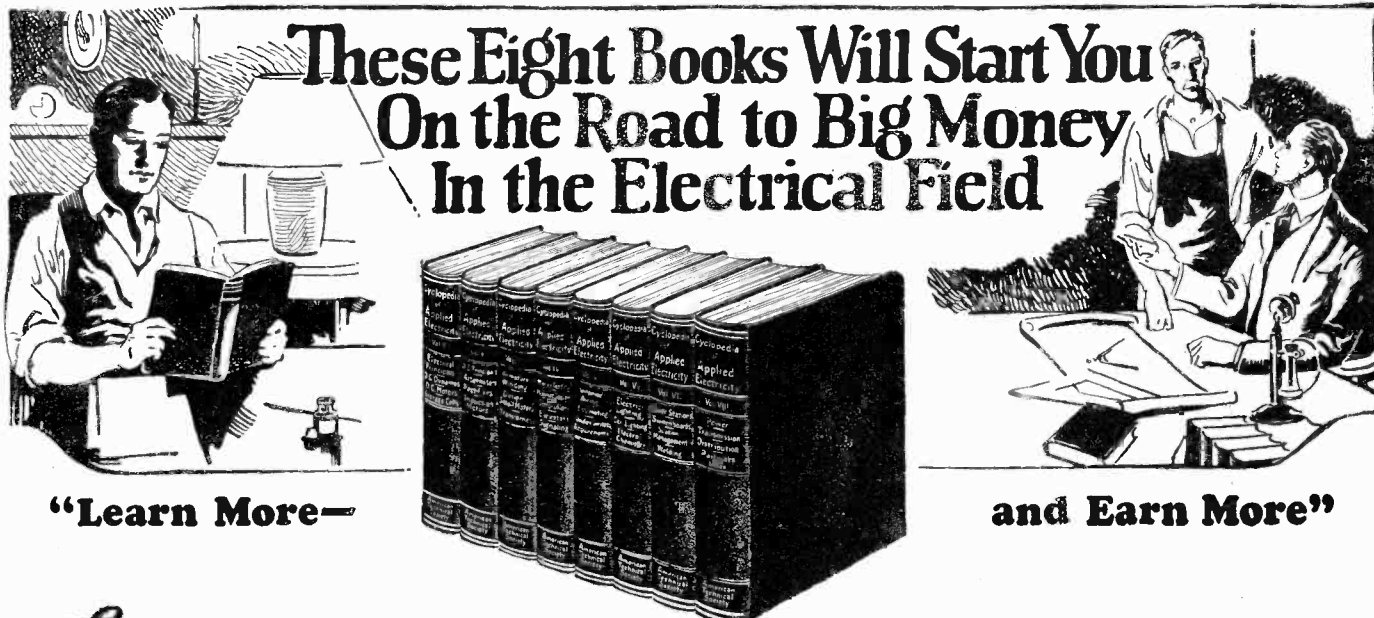

# The Student of Today Is the Expert of Tomorrow

**I**F you want to make a place for yourself in the electrical field—if you want to be assured of a future that will mean opportunity, satisfaction, accomplishment and financial reward—you will have to start *now* to acquire the *knowledge* that wins *success*. In other words you will have to *Learn* more before you can *Earn* more.

**Knowledge Is the Thing That Counts**  
The *trained* man gets paid for what he *knows*—for his ability to instruct and direct those who “never found time to study.” The other fellow gets paid for what he *does*—for his willingness to plod along and do what he is *told* to do. Yet, knowledge, the one thing that makes such a vast difference in dollars and cents on pay day, is just as readily available to the one as it was to the other. That knowledge is now available to *you!*

### Start to Prepare Today

The student of today is the expert of tomorrow. If you are plodding along at a low salary—doing ordinary jobs that anyone can do—don’t blame it on the boss or envy the opportunities that are his. You alone are to blame. The very knowledge which you lack—the wealth of information which he possesses—is within your reach if you will but step up and take it. Everything that you ought to know and will have to know in order to qualify for a big pay job in the electrical field is contained in the eight splendid volumes of “Applied Electricity.” The

coupon will put these eight big books in your home for study, reference and help at a cost of *only ten cents a day*.

### Get These Pay-Raising Books

The “Cyclopedia of Applied Electricity” was published by the American Technical Society for the purpose of helping those who are anxious to increase their knowledge and pay through pleasant study at home. This remarkable set of books has helped thousands of ambitious men who were willing to learn the real facts about their work, but who were unable to devote time and money to a correspondence course or special school training. Think of it—eight big volumes, 3800 pages, 3000 pictures, printed on fine paper, handsomely bound, stamped in gold and indexed for ready reference. All yours for only 10 cents a day—with a Consulting Membership in the Society absolutely free.

### Send No Money

Don’t send a cent in advance—merely the coupon. When the eight big volumes of “Applied Electricity” arrive, deposit only \$3 with the postman and examine them 5 full days. If you decide to keep them, send us \$3 monthly for nine months; otherwise you may return them and get your money. Don’t miss this unusual opportunity to *Learn* more and *Earn* more. Mail the coupon today! American Technical Society, Dept. E625, Chicago, U. S. A.



### 20 Experts Are Waiting to Help You

Back of these eight big volumes of “Applied Electricity” stands a staff of 20 Experts who are ready and willing to help you until you are expert yourself. This expert advisory service is offered to students by the American Technical Society in the form of a

### FREE Consulting Membership

By mailing the Special Coupon for a set of these splendid home study books you get the free help and advice of this Expert Advisory Staff. With your books as a work and reference library at home, and the free service of these 20 experts, you can quickly qualify for a big pay job in the electrical field. A letter or wire to the Society will bring you the information and help you need. You can use this service daily if you like.

**Read the Coupon Thoughtfully—Then Mail It!**

### Special 5 Day Examination Coupon

AMERICAN TECHNICAL SOCIETY  
Dept. E 625, Chicago, U. S. A.

I want to *Learn* more and *Earn* more. Please send me, postpaid, the eight volumes of “Applied Electricity.” I will deposit \$3 with the postman on arrival. If I decide to keep the books, I will send you \$3 monthly for nine months; otherwise I may return them in 5 days and get my money. It is understood this entitles me to a Free Consulting Membership in the Society which I may use daily if I like.

Name.....  
Street.....  
City..... State.....  
Employed by.....



# Master Electricity By Actual Practice

The only way you can become an expert is by doing the very work under competent instructors, which you will be called upon to do later on. In other words, *learn by doing*. That is the method of the New York Electrical School.

Five minutes of actual practice properly directed is worth more to a man than years and years of book study. Indeed, Actual Practice is the only training of value, and graduates of New York Electrical School have proved themselves to be the only men that are fully qualified to satisfy EVERY demand of the Electrical Profession.

## The Only Institution of the Kind in America

At this "Learn by Doing" School a man acquires the art of Electrical Drafting; the best business methods and experience in Electrical Contracting, together with the skill to install, operate and maintain all systems for producing, transmitting and using electricity. A school for Old and Young. Individual instruction.

### Over 8,000 Graduates are Successful Men in the Electrical World

No previous knowledge of electricity, mechanics or mathematics is necessary to take this electrical course. You can begin the course now and by steady application prepare yourself in a short time. You will be taught by practical electrical experts with actual apparatus, under actual conditions.

The N. Y. E. S. gives a special Automobile Ignition Course as an advanced training for Auto Mechanics, Garage Men and Car Owners. The course covers completely all Systems of Ignition, Starters, Lighting and other electrical equipment on automobiles, motor boats, airplanes, etc.

*Let us explain our complete courses to you in person. If you can't call, send now for 64-page book—it's FREE to you.*

New York Electrical School  
29 W. 17th St., New York, N. Y.

Please send FREE and without obligation to me your 64-page book.

..... NAME  
 ..... STREET  
 .....CITY .....STATE

# New York Electrical School

29 West 17th Street, New York

# Science and Invention

H. GERNSBACK, EDITOR AND PUBLISHER  
H. WINFIELD SECOR, ASSOCIATE EDITOR  
T. O'CONOR SLOANE, Ph.D., ASSOCIATE EDITOR

Editorial and General Offices, - - - 53 Park Place, New York

*"Those Who Refuse to Go Beyond Fact Rarely Get As Far As Fact" - - - HUXLEY*

## Important Radio Inventions

By HUGO GERNSBACK

**D**URING the past few months two very important radio inventions have been made which will revolutionize the radio art during the next decade. As a rule radio inventions are only improvements on existing devices. It is seldom indeed that something big comes along that causes a stir in the radio world. Nevertheless, this actually happened not only once, but twice, during the past few months.

The inventions to which we refer are now known as the *Solodyne* principle and the *Crystodyne* principle.

The *Solodyne* principle is the invention of Messrs. G. W. Downing and K. D. Rogers, two young English technicians. The invention, in a few words, does away with the "B" battery, as well as all high tension current. The tubes are supplied only with the "A" battery current, no other source of current supply being used. It is a well known fact, known only too well to every radio fan, that about 80 per cent of the vacuum tubes in use are *blown out* when accidentally shorted with the "B" battery. Only

some 20 per cent of the tubes wear out naturally. By means of the *Solodyne* principle this is done away with entirely. Not only that, but in radio outfits embodying the *Solodyne* circuit, operation of the set becomes extremely quiet.

Everyone knows, particularly when operating a loud speaker, that there is always a certain roar that comes from the horn even when no one is speaking or singing from the particular station to which one is listening. This extraneous sound is done away with entirely in the *Solodyne* outfit. Supreme quiet reigns.

The music or voice comes on with a startling suddenness and is usually much clearer. While by means of the new *Solodyne* principle no greater distances are claimed, nor any other remarkable stunts, the mere fact that in a short time we will have radio sets without "B" batteries is in itself a great advance.

Also when receiving long distance signals, the "B" batteries usually give enough additional noise in the head phones or loud speaker to kill the sounds of the far distant voice or music, which is not the case in a *Solodyne* circuit. Furthermore, static seems to be reduced somewhat as it is no longer amplified by the "B" batteries.

The second invention, which undoubtedly is more important than the first one, has been termed the *Crystodyne* principle. This is the invention of a young Russian, Mr. O. V. Lossev. Mr. Lossev has taken the humble little crystal that we have used so many years as a detector only and has succeeded in making it oscillate. By means of this sensational discovery it is now possible to do anything and everything that the vacuum tube does. The crystal, which *must* be a combination of *zincite* and *steel contact*, now not only oscillates, but it can be used to detect, amplify and regenerate, just exactly as does a good vacuum tube. Not only that, but the crystal can also be used to transmit waves, the same as does the vacuum tube.

By means of a few pieces of *zincite* crystal, some resistances, a few coils of wire and a microphone, you can now own a wireless telephone that actually sends out your words into space. This has already been accomplished by means of a single crystal over a distance as great as three-quarters of a mile in Russia.

On the receiving end the tubes are entirely

replaced by means of the *zincite-steel* detectors. Just as you now build a six tube super-heterodyne set, so will you be able in the near future to build a six crystal set. Not only that, but the *Crystodyne* circuits are very much simpler because only one battery is used to supply the power to the crystal. The circuits themselves are also very much simplified. There is less intricacy in the wiring and there are other obvious simplifications.

Important as these two inventions are, they are only at the present time in an experimental form. In no instance have they been perfected in such a way that they can leave the laboratory and enter into the commercial stage. The two inventions, however, have opened up a tremendous field for experimentation. Of this there can be no doubt. Particularly the *Crystodyne* principle, which adapts itself to the young man whose pocket-book is not too well supplied and who cannot afford to buy many vacuum tubes. To him a new world is opened up.

Those contemplating buying radio outfits should thoroughly understand, however, that these two inventions will not affect seriously the radio trade for some years to come. It will take years before *Solodyne* outfits or *Crystodyne* outfits will appear upon the market.

Revolutionary inventions as a rule do not reach the public overnight. They take a long time before being translated into actual practice. It was so with the automobile, the telephone, the phonograph and hundreds of others. While important improvements have been made from time to time on these, still everyone remembers how orderly the progress was and how long it took to translate into actual practice. Present-day radio outfits, therefore, will be good for years to come.

Those interested in the *Solodyne* principle will find a full account of it in the August issue of *RADIO NEWS*, while the *Crystodyne* principle is fully discussed in the September issue of the same publication.

One of the very important features connected with the *Crystodyne* principle is that Mr. Lossev has, as far as we are informed, not taken out any patents on this epoch making invention. In other words, anyone could manufacture a future *Crystodyne* set without being interfered

with, and without the necessity of paying a royalty or license on the particular set he chooses to manufacture.

This does not mean to say that everything will be rosy, for we may rest assured that in the years to come there will be many notable improvements and additional features that will be incorporated in the *Crystodyne* principle; and many of these will be patented.

One of the important things as yet to be discovered is a real fixed crystal detector. It is more or less difficult with the *Crystodyne* to-day to keep it adjusted, on account of the moving point, necessary

to find a sensitive spot. Perhaps a fixed *zincite-steel* point crystal, enclosed in a vacuum may in time become a very powerful competitor to the vacuum tube.

Much work remains to be done in this direction and it offers the inventor a most lucrative field of endeavor right now.

*SCIENCE AND INVENTION*, beginning next month, will run a series of articles on these two new inventions, and will keep its readers informed of all new progress with them.

### I BELIEVE

that television by  
Radio will be in  
everyday use within  
the next ten years.

### I BELIEVE

that even a fair under-  
standing of  
Radio, is an education  
by itself.

### I BELIEVE

that the man who  
has not built and  
worked a radio set,  
missed one of the  
greatest thrills of  
the century.

### THE GOLDEN AGE OF SCIENCE

is now symbolized by the golden  
cover of *SCIENCE & INVEN-  
TION*. LOOK FOR THE GOLD  
COVER every month!

# Liquid Fire to Protect Jungle Explorers

By J. G. FREDERICK

**I**N order to study the life and habits of the gorilla, Dr. W. B. Reid, a well known surgeon and former Mayor of Rome, New York, is venturing into the heart of African jungles with no arms save liquid fire projectors, such as used during the World War. This instrument of warfare has several distinct advantages from the point of view of the jungle wayfarer. It can be aimed just as easily as the best rifle, and carries its flame amply far enough to give the user protection against any herd of wild beasts. The small sketch in the center of this page at the left, shows the construction of the apparatus. One cylinder contains compressed nitrogen and the other a mixture of oils. They are forced under pressure out through a connecting hose and a nozzle, where they are ignited. Various means of ignition may be used. A toothed wheel and certain or an electrical device may perform this function, and both are carried by the party. In point of efficiency, it has a distinct advantage over the rifle or other form of firearms, since one explorer equipped with this death-dealing apparatus can put to flight—at least he can effectually protect himself from—even a herd of bull elephants on the rampage. With quick maneuvering even the swift feline tiger would not have the slightest chance at attacking or injuring an explorer equipped with this apparatus.

It is to be put in the present instance to a more humane purpose than that for which it was originally devised. Dr. Reid states unequivocally that the instrument will not be used except in cases of extreme danger to members of the exploring party. The illustrations on this page gives the artist's conception of how the jungle explorers may effectually protect themselves in any expediency with the use of this weapon developed during the late World War, the modern version of the old time Greek fire.

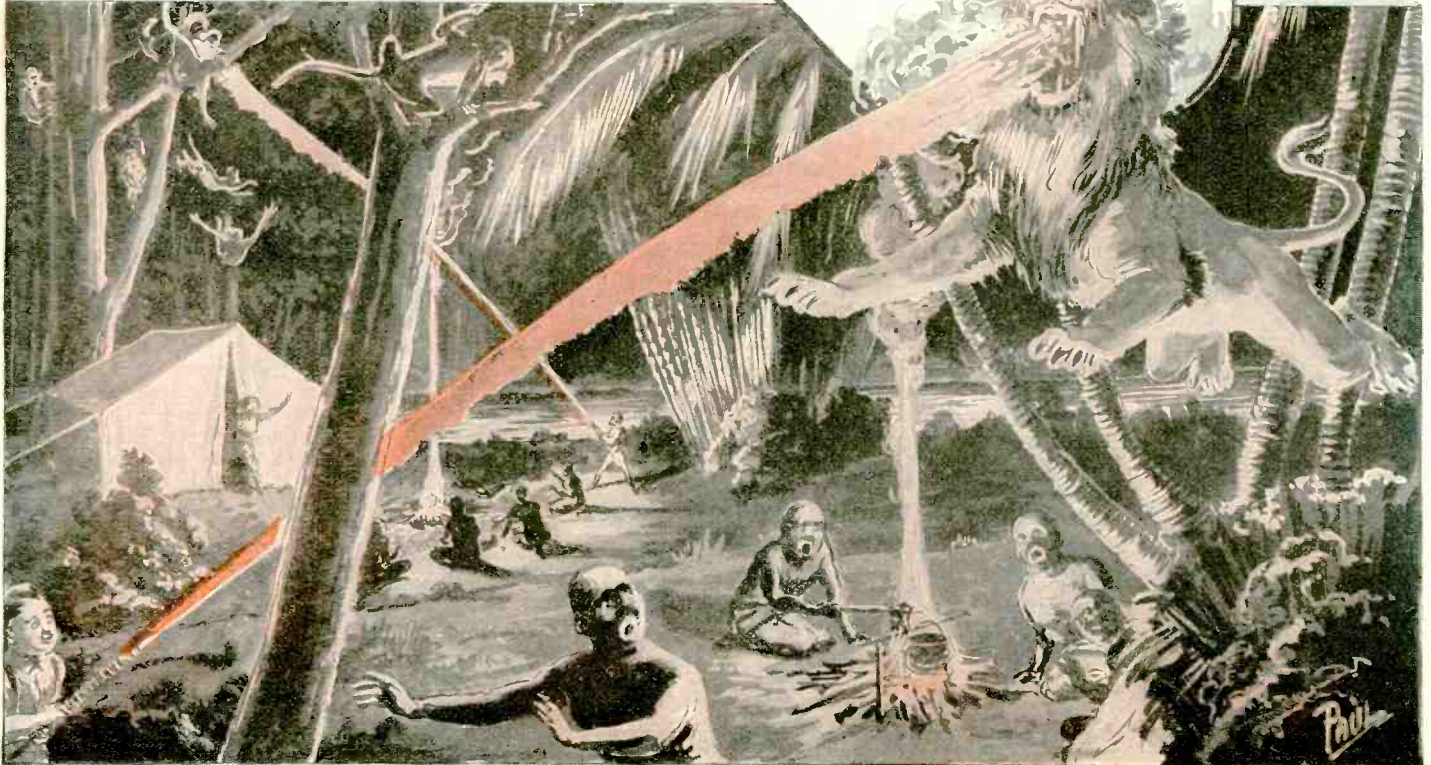



# At Last! Real Wind Power

By C. A. OLDROYD, A. E.

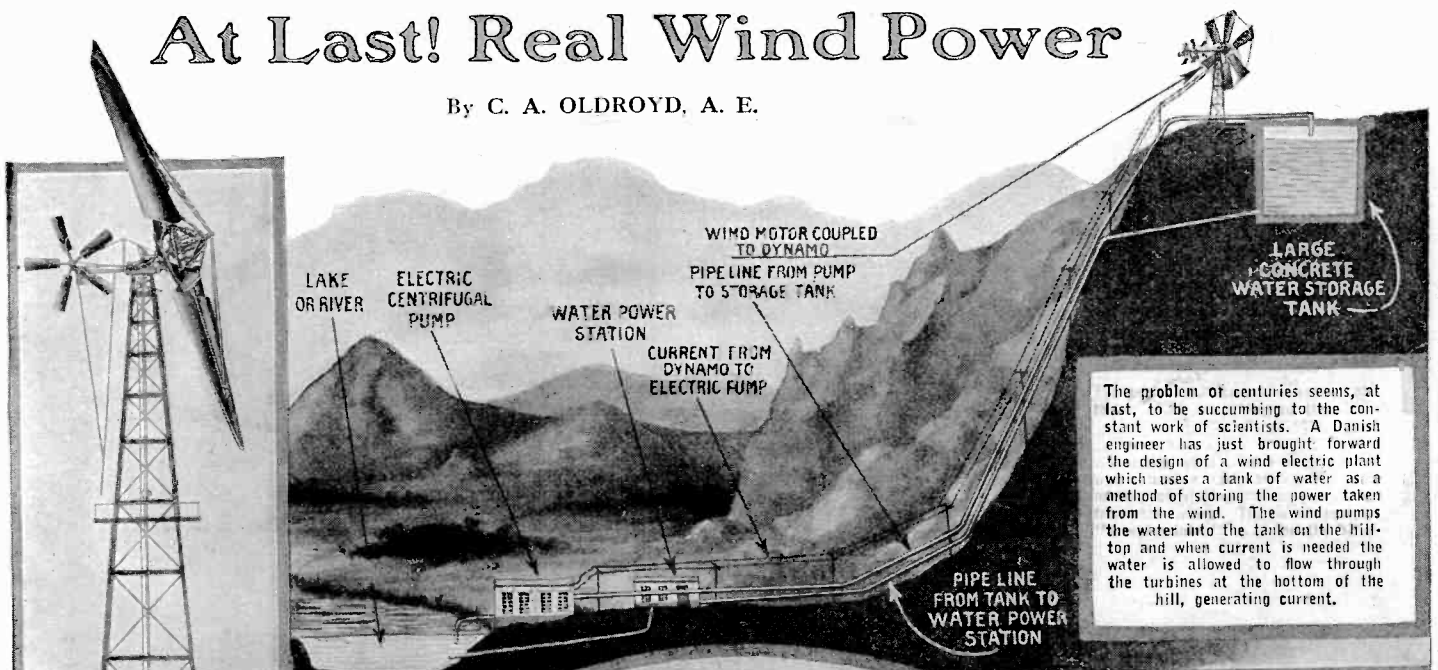

The problem of centuries seems, at last, to be succumbing to the constant work of scientists. A Danish engineer has just brought forward the design of a wind electric plant which uses a tank of water as a method of storing the power taken from the wind. The wind pumps the water into the tank on the hill-top and when current is needed the water is allowed to flow through the turbines at the bottom of the hill, generating current.

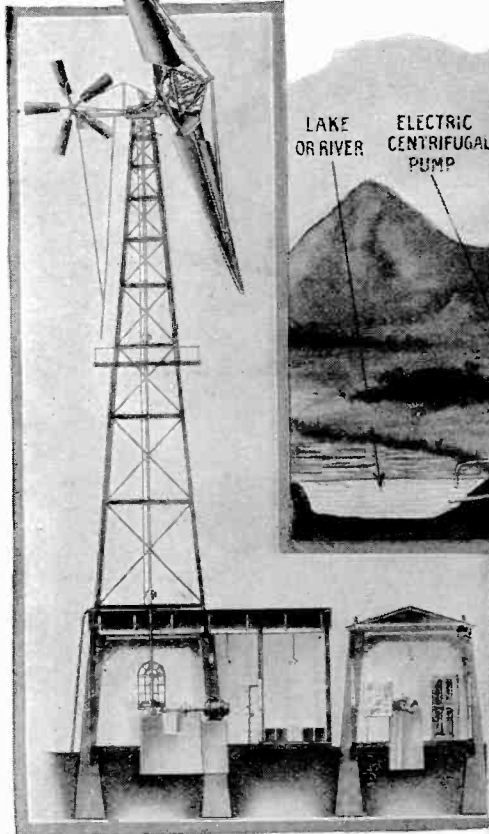

Above and at the right are shown two views of the novel wind mill used by the Danish engineer. The new idea in wing construction will at once be noticed. The insert above and to the right shows a cross-section of one of the arms, which is very similar to the cross-section of an airplane wing. Only six arms are used to the unit for the sake of efficiency.

SECTION THROUGH THE VANE OF AN AGRICCO WIND TURBINE NOTICE THE SIMILARITY WITH AN AEROPLANE WING SECTION

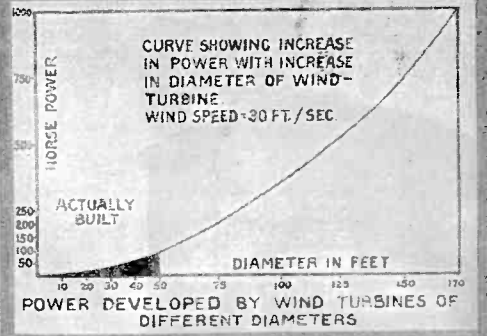
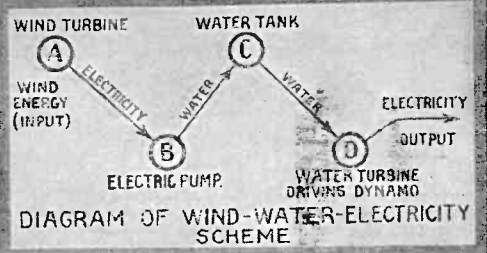
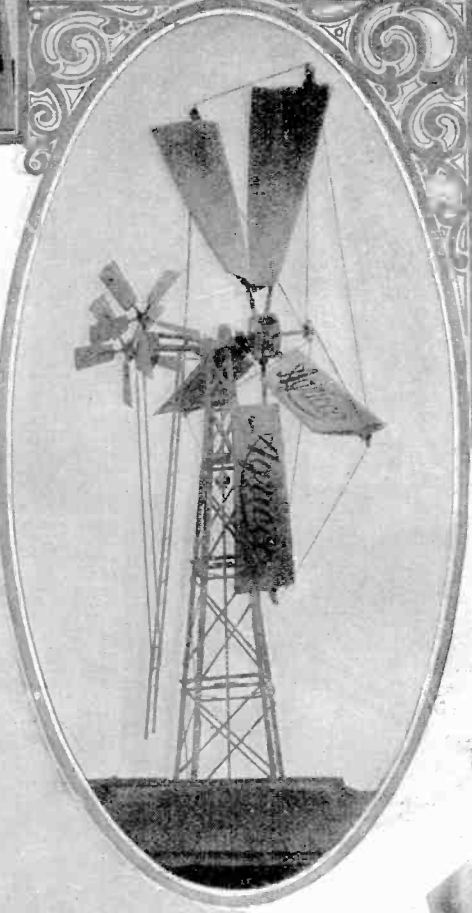

The curve immediately above shows the remarkable increase in horse-power as the diameter of the wings increase. Fifty feet is about the largest diameter mill that has been constructed to date. The larger the mills are made, the greater is the proportional increase in horse-power. Above the curve are shown the various transitions through which the power is carried in this system of developing electricity from the wind. The wind pumps the water through an electric pump to the top of the hill. The water is led from the tank to the turbines as needed, and the turbines drive generators, giving electric power for distribution to consumers.

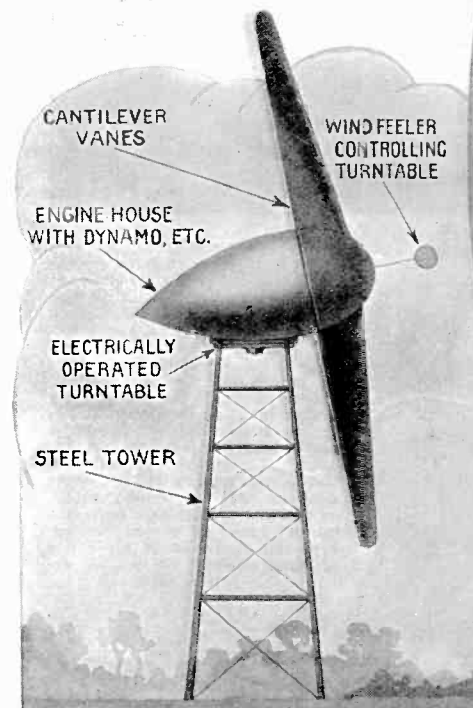

Above is shown a more advanced engineering design giving a probable future form of the big wind engine. The blades are cantilever type with no wires or bracing struts exposed. A wind feeler controls the shift of the machine towards the wind. The blades are attached directly to the front part of the housing, which revolves with them. The rear of the housing contains an electric generator connected directly or through gears to the shaft. The whole affair is streamlined. The position of the machine is changed by an electrically driven turn-table which works automatically.

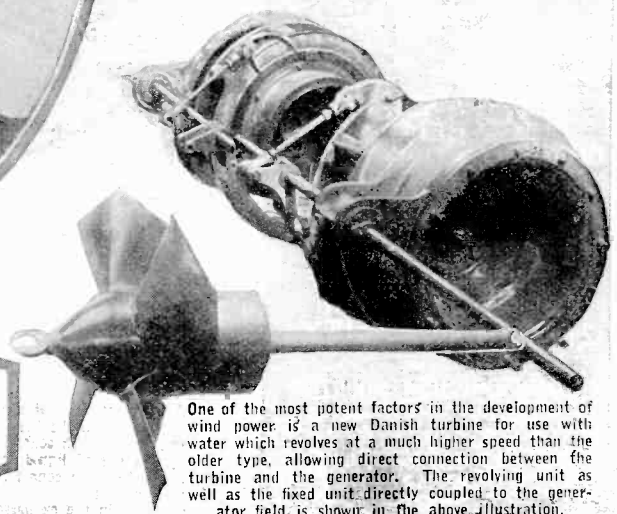

One of the most potent factors in the development of wind power is a new Danish turbine for use with water which revolves at a much higher speed than the older type, allowing direct connection between the turbine and the generator. The revolving unit as well as the fixed unit directly coupled to the generator field is shown in the above illustration.

# What Causes the Aurora Borealis?

By DONALD H. MENZEL Ph.D.

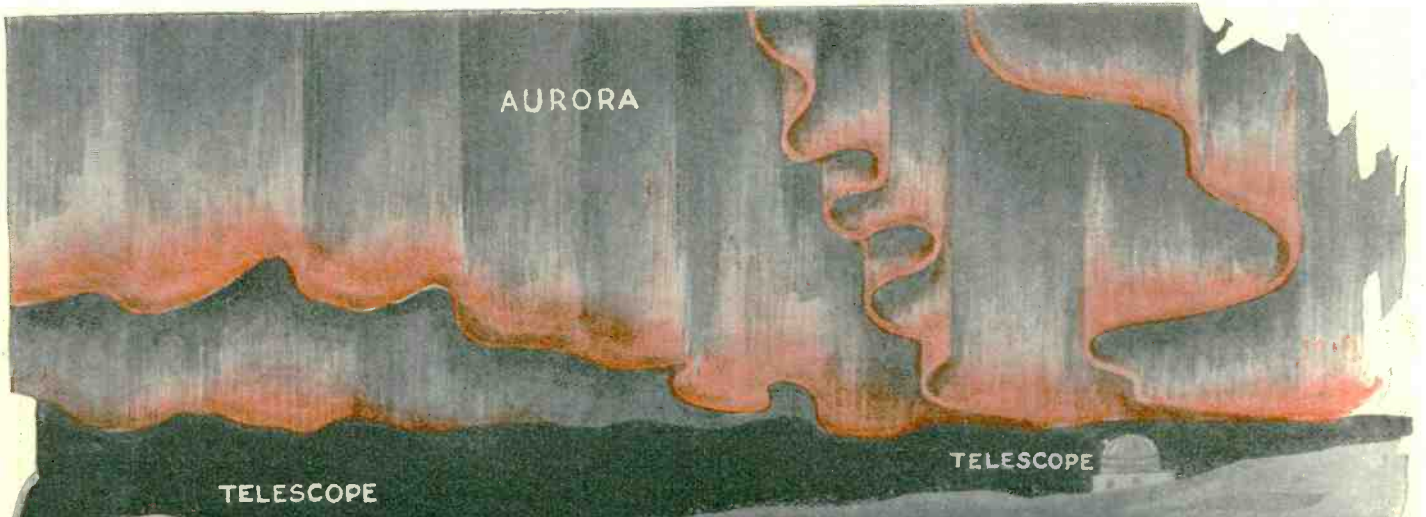

Above is given a typical view of the famous aurora as it might appear in an extremely northern or southern latitude. It hangs about over the sky like the great folds of a multi-colored drapery. What causes it science has been wondering for years. There has been a constant watch kept on all celestial demonstrations which accompany it. The two telescopes and observatories illustrated in the above sketch show how one of the first investigations regarding the aurora was carried out. The two telescopes were pointed to different spots on the aurora, and through the angular measurements to these points, the height of the aurora given in the sketch immediately below was ascertained.

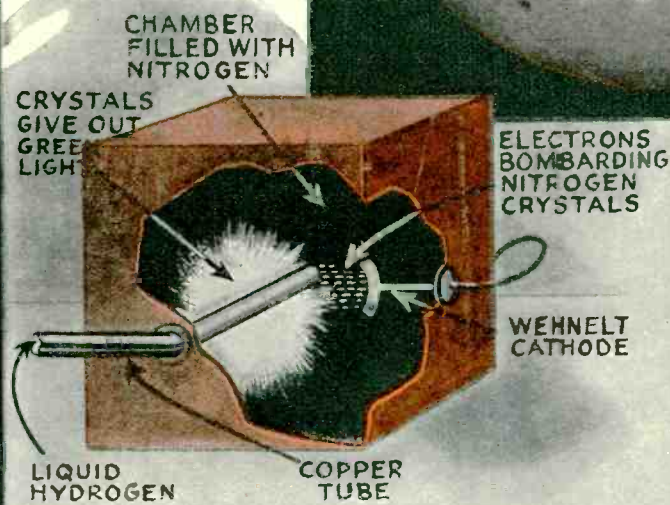
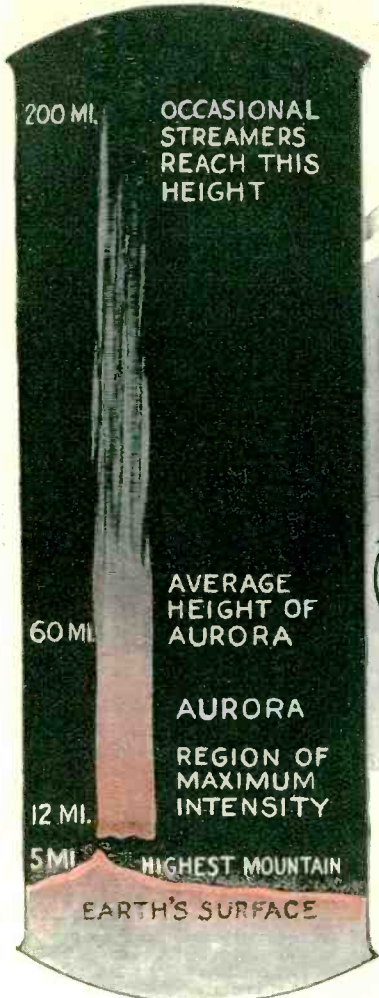

It was only recently that any even seemingly logical explanation for the existence of this great phenomenon was evolved. Prof. Vegard found in some investigations that the peculiar greenish hue of light given out almost constantly by the aurora could be identified with that due to ignited nitrogen. He decided that this demonstration was very similar to that observed in a Geissler tube. He then inferred, since all large demonstrations of aurora have been noticed in connection with sun spots and other solar disturbances, that in the upper atmosphere where extremely low temperatures obtain, nitrogen did not probably exist as a gas but rather as a solid or dust. From this observation he devised the apparatus shown at the left and described below.

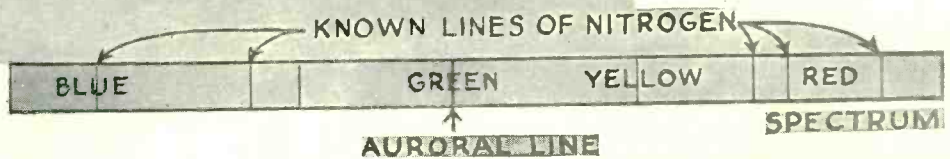

After observing that sun spots such as that shown above in the center of the page were intimately connected with the aurora, and acting on the thesis that a powerful bombardment of electrons resulted from such solar disturbances, the apparatus above was built, which consisted of nitrogen deposited on the surface of a copper rod and a cathode. The solidification was effected by the use of liquid hydrogen for the reduction of temperature to the necessary point. The Wehnelt cathode was placed across from the copper rod in the air exhaust chamber, and a high pressure electric circuit (voltages ranging from 200 to 750 volts were used) was connected to the cathode. Immediately the same greenish hue, constantly evident in the aurora, was produced in the exhausted chamber. This led to the view that the bombardment of electrons from the sun striking solid or crystallized nitrogen in the upper stratum of the atmosphere was the cause of this far-famed phenomenon.

# Can Panama Canal Be Defended?

By GRASER SCHORNSTHEIMER, Staff Naval Editor

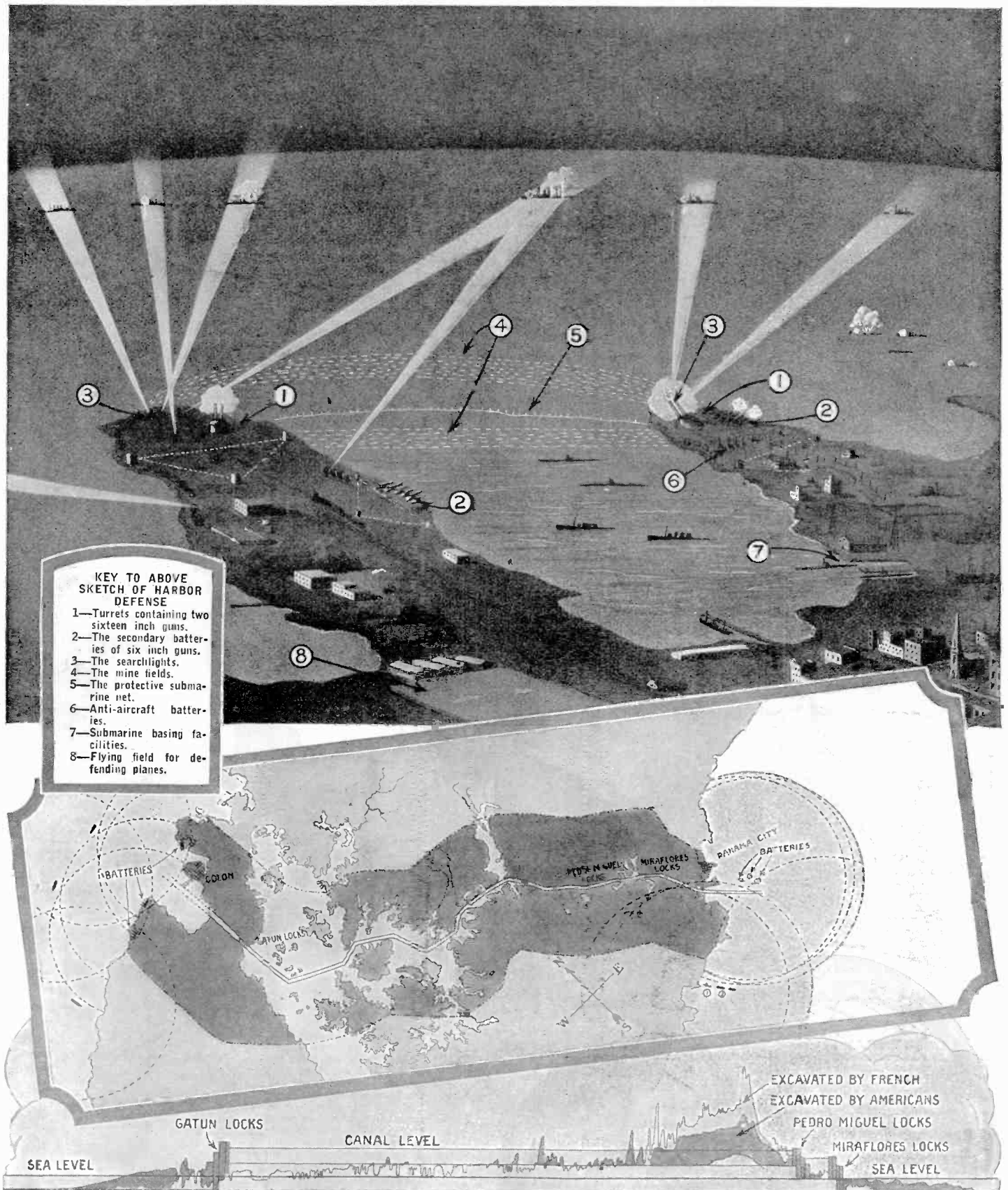

**A**UTHORITIES have recently stated that the Panama Canal should be brought to sea level for the sake of fortification. However, the Panama Canal is a weak point in the national defense, because the ordnance and equipment at present installed are antiquated. The sketch at the top of the page with the key gives an idea of the procedure in a naval battle, when the forts are notified of the presence of enemy vessels near or within range. Searchlight batteries immediately seek out the vessels. The heaviest artillery is then turned on them and fire is opened. Small destroyers of the enemy fleet usually attempt to come in close, under cover of course, and fire at the searchlight batteries and other important units. The smoke screen very often finds its chief use at this point. Adequate airplane observation, however, makes the smoke screen

worse than useless since the planes may observe the movements of the enemy's ships from above. Of course, the water immediately in front of the fortifications is protected from submarines and other small craft by mine fields and nets. In the center illustration is graphically shown how the old 12" and 14" calibre guns, which are now the chief supports of the canal fortifications, might be easily outdistanced by the larger guns and better armament of present day navies. The best point for perfect protection of a canal is not bringing it to sea level, but the installation of adequate artillery and perfection of the present fortresses. The cross-section shown at the bottom of the page gives a very clear idea of the huge amount of work that would be necessitated in bringing the canal to sea level.

# The Dangerous House Fly

Methods of Combatting This Greatest of Germ Carriers.

By DR. ERNEST BADE



Above is shown a bottom view of the house fly's proboscis through which it takes food. Incapable of eating solids, the fly dissolves them in saliva before eating. Since the fly is partial to liquid foods, keep them covered.

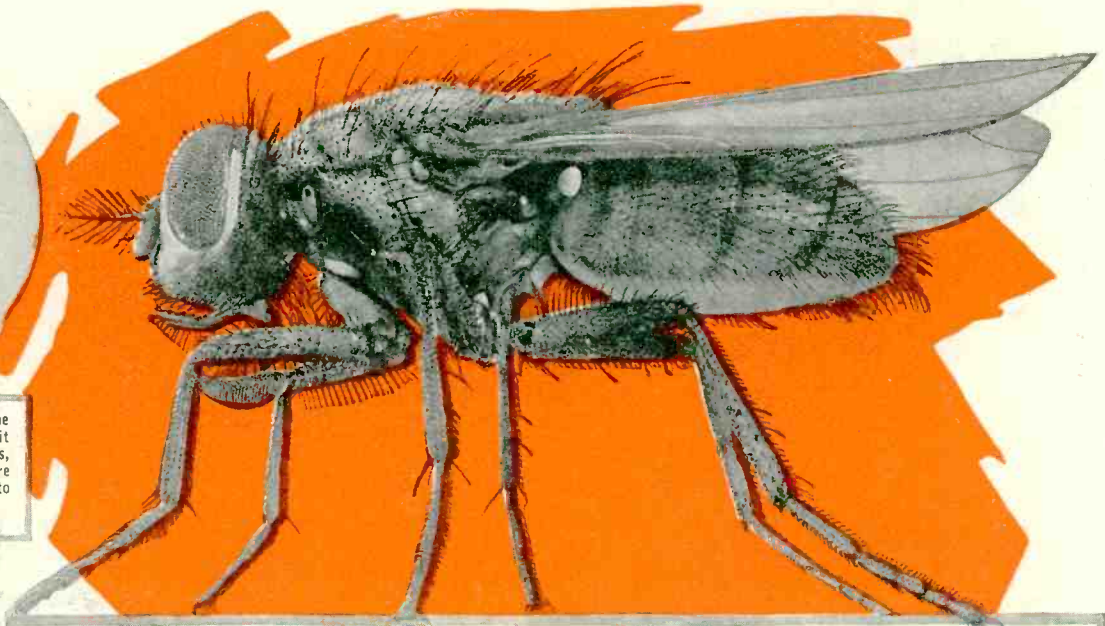

Although the house fly in itself is harmless, its ability as a germ carrier for contagious diseases makes it one of the most feared pests of modern times. The picture above (by courtesy of the American Museum of Natural History) is of such magnitude as to give us a close acquaintance with the adult fly. Since it makes food of all sorts of garbage, offal and waste, and shortly after secures nourishment from the food in shops and in our homes, it is logical that the germs which infest the waste matter will find their paths to the food we eat, and consequently to our bodies, through the feet, legs, body and proboscis of the

fly as a carrier. An added danger is that the fly considers milk one of its choicest foods and since baby also makes it a large part of his sustenance, it is therefore very necessary that particular care be taken to keep flies away from milk. Open wounds on cattle or men are also a very dangerous spot for infection from flies, since germs may be carried directly into the blood stream in this way.

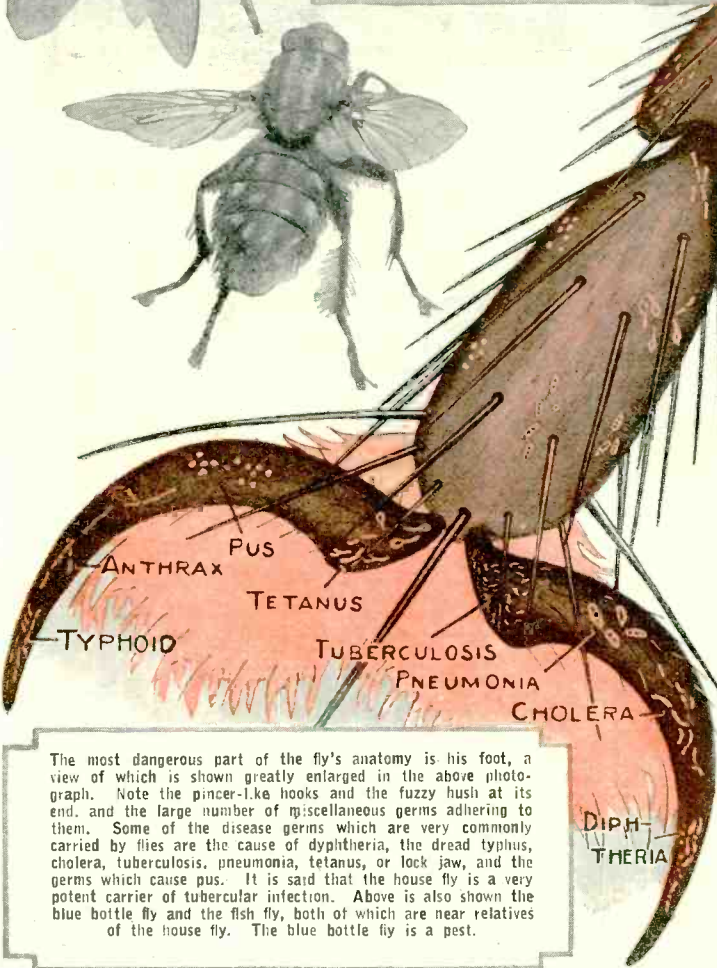

The most dangerous part of the fly's anatomy is his foot, a view of which is shown greatly enlarged in the above photograph. Note the pincer-like hooks and the fuzzy hush at its end, and the large number of miscellaneous germs adhering to them. Some of the disease germs which are very commonly carried by flies are the cause of diphtheria, the dread typhus, cholera, tuberculosis, pneumonia, tetanus, or lock jaw, and the germs which cause pus. It is said that the house fly is a very potent carrier of tubercular infection. Above is also shown the blue bottle fly and the fish fly, both of which are near relatives of the house fly. The blue bottle fly is a pest.



In the illustrations above and to the right are shown some very effective methods of killing flies. An extremely good but harmless poison can be made by soaking chips of quassia wood, one hundred parts, in fifty parts of water for a day, after which the mixture is boiled half an hour, allowed to stand another day, pressed through a rag, mixed with fifteen parts of molasses and evaporated until only twenty parts remain. Then add five parts of alcohol and seventy-five parts of water, soak paper in it, and let the paper stand in a dish of water. Sticky fly paper may be made by melting three parts of rosin with one part of linseed oil adding one part of honey. Paint on paper while hot.

# Widely Diversified Applications of Science

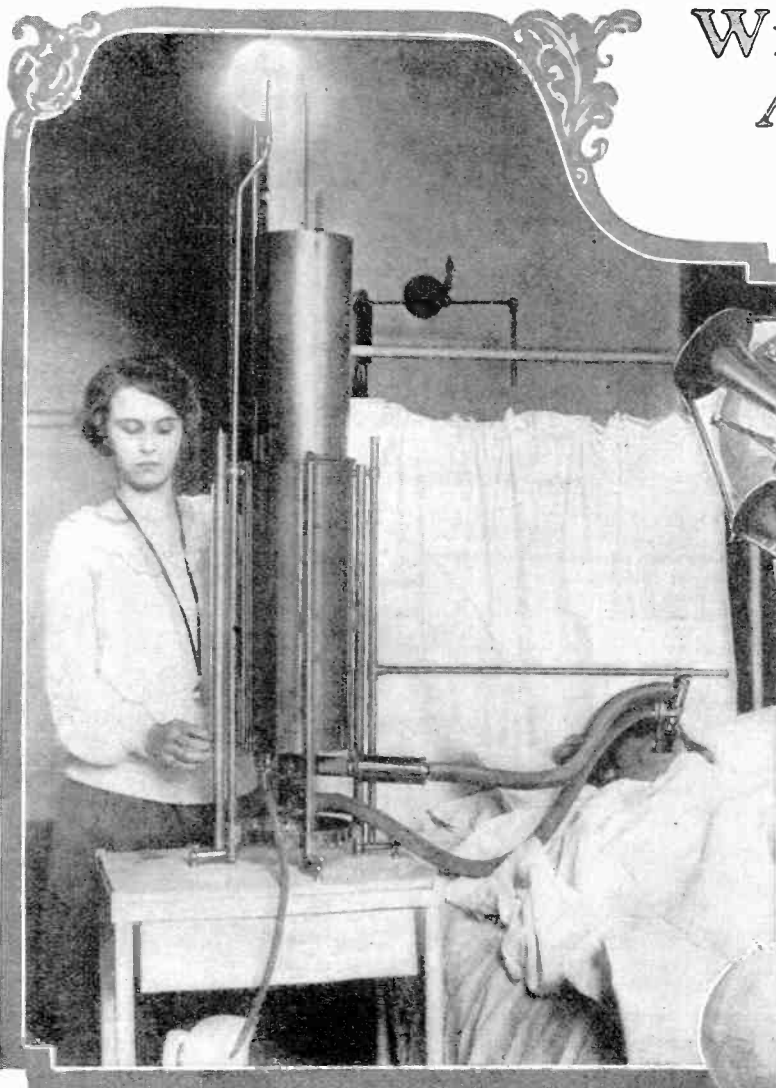

Ever hear of the drunkenness detector? Well, here it is, ladies and gentlemen, but in this case the patient is not supposed to have imbibed something stronger than one-half of 1%. This new instrument of science, known as the "metabulur," is shown in use in a Boston hospital in an effort to ascertain what makes people fat. In the photograph we see Miss Louise Harris operating the mechanical breath-sniffer at the Boston City Hospital, measuring the various amounts of different gases in the patient's breath for the purpose aforementioned.

Fire in an airplane or dirigible is one of the most dreaded catastrophes and aviators everywhere will no doubt be interested in the latest safety device shown below, which is nothing less than an automatic fire extinguisher for aircraft. If flames break out or an undue temperature rise takes place at any point about the plane, where suitable temperature rise detectors are placed, the fire extinguishing medium, which may be liquid or gas, is liberated at these points, quickly snuffing out the fire.

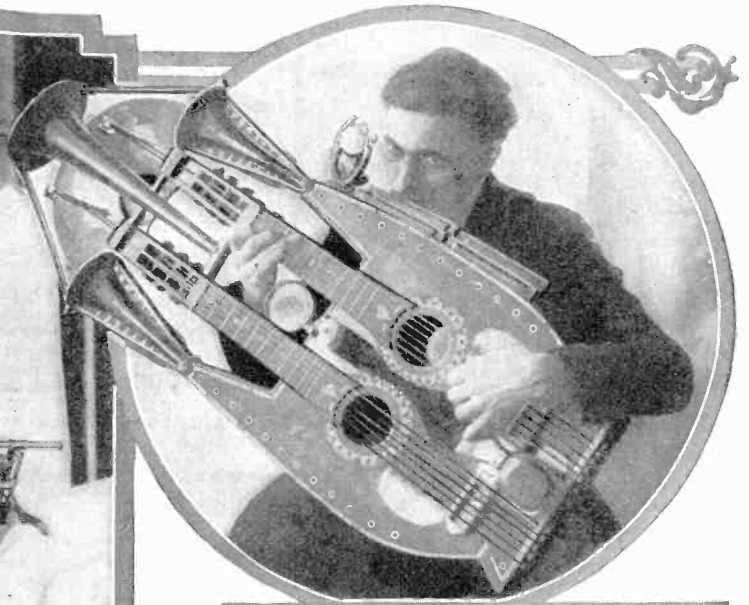
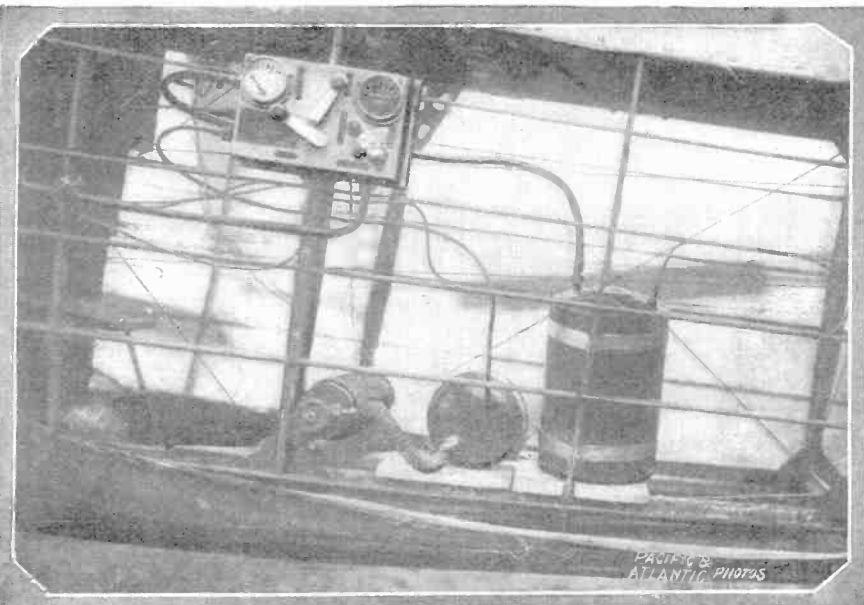

Behold Signor Miguel Juan, a Spanish genius with his one-man jazz guitar. This unique instrument is really fourteen different ones all in one, and when properly played is said to give the effect of a whole jazz band. The photo shows the Signor playing the four mouth organs.

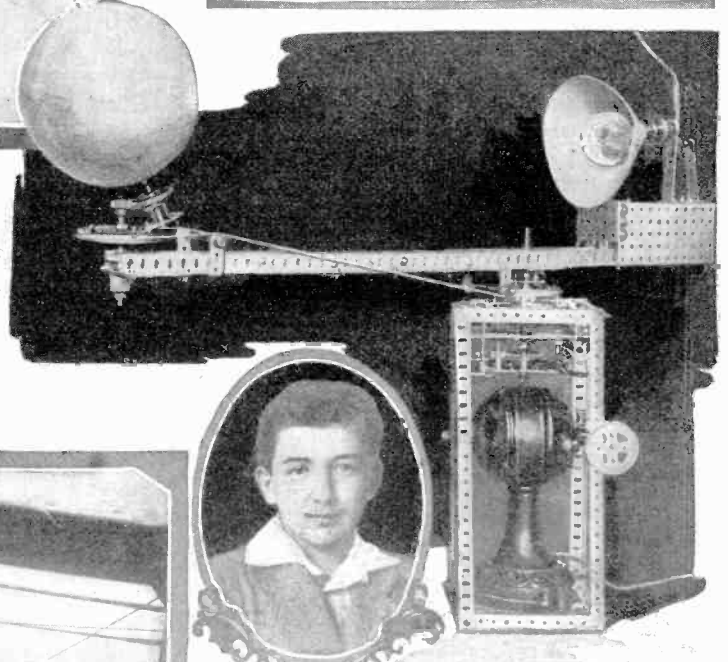

The twelve year old astronomer, Master Louis Cantenot of Dijon, France, has built the intricate apparatus shown above, which device shows in a clear manner the movement of the planets. This very interesting instrument is the result of Louis' deep study of the subject, together with his personal observations of the movements of the planets and stars in the heavens. He constructed this apparatus with the aid of a toy Meccano set, an electric lamp and socket, together with a motor of an electric fan. The young astronomy student's model operates from the electric light current in his home and works exactly on time; the earth rotating once in 24 hours, etc. A miniature globe such as those bought in a map shop represents the earth, and the electric lamp with its reflector takes the place of the sun. The gear wheels to be found with the toy building sets supply the necessary parts for giving the correct time movement to the whole affair.

# Advances in Lumbering



Below at 4 we have the latest development in dyeing wood wherein, by a process newly discovered, the whole fibre is colored while the tree is still growing. The dye is injected as shown, and within two days the process of sap absorption colors the whole tree.

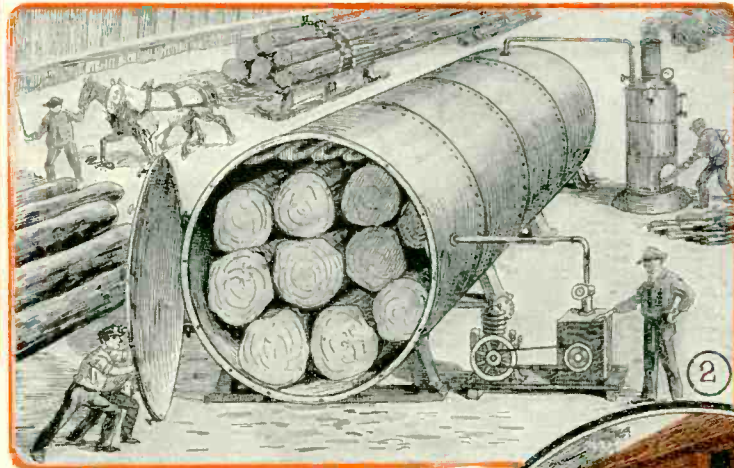

Above is shown the new vacuum process of drying lumber. Recent experiments in Sweden have shown this process capable of delivering thoroughly dried wood, ready for the builder's use, three days after the tree is cut from the stump. The logs are enclosed in an air-tight casing, and the exhaustion of air from the casing quickly removes all moisture.

The two recent advances in the lumbering trade, shown on this page, bid fair to have a far reaching effect in the near future. The automatic drying process using vacuum, shown in the first two illustrations, will save thousands of dollars and months of time in getting lumber to the market. Although the dyed trees shown in the bottom illustrations will give wonderful decorative effects, they will still be painted with varnish for protection from weather.

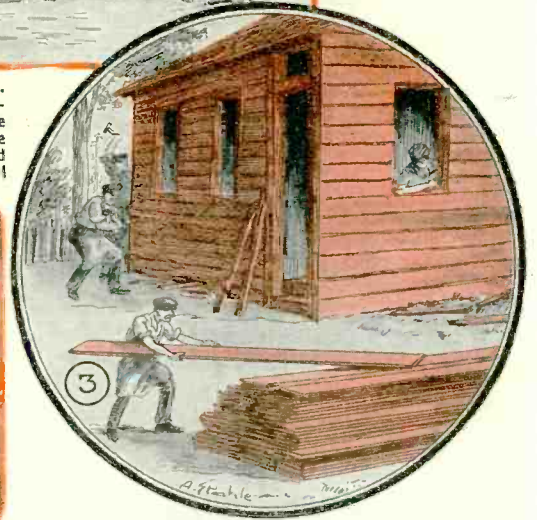
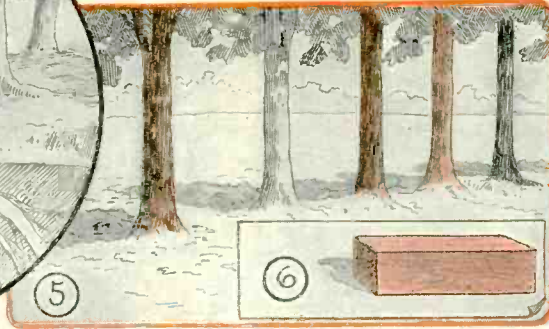
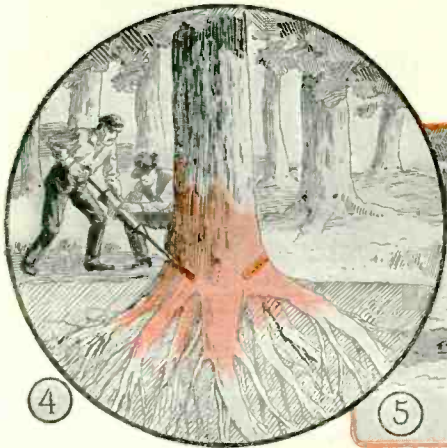

# Collapsible Dirigible Mast

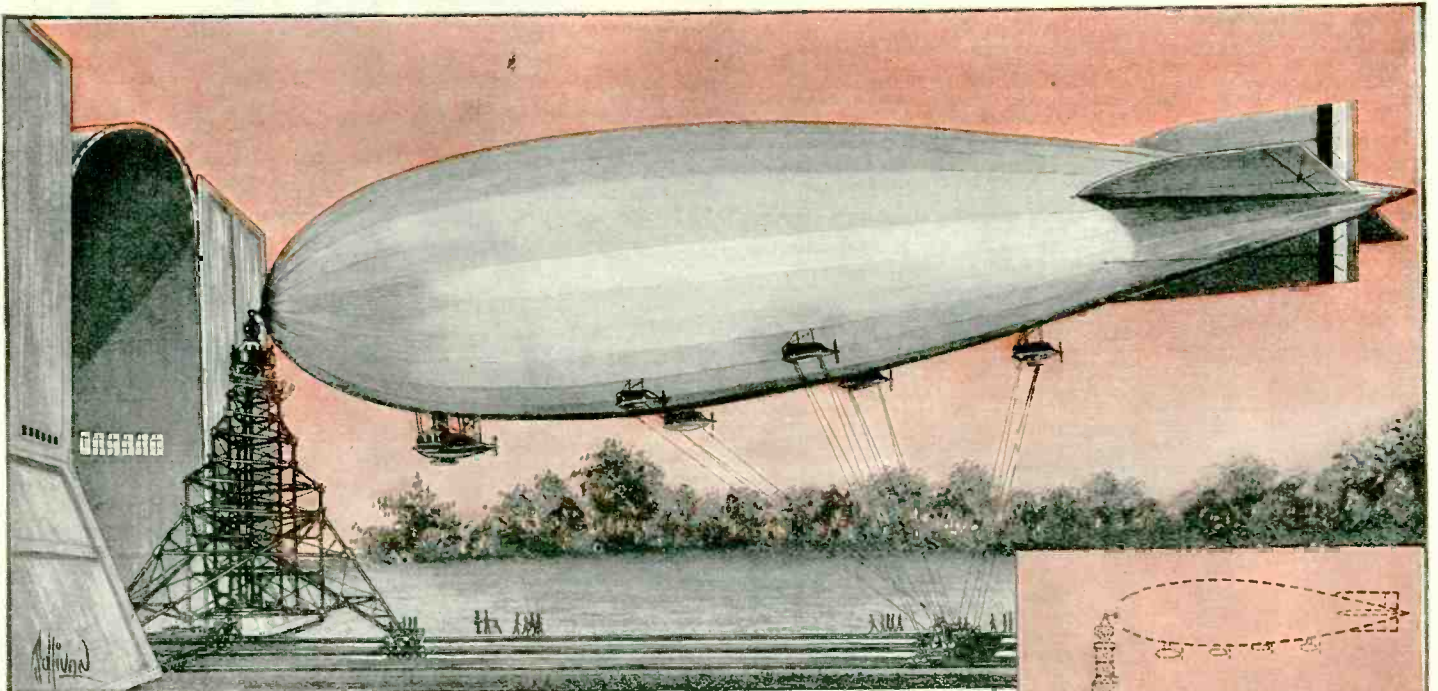

**P**RACTICALLY all the great accidents in connection with dirigibles have occurred while mooring them, since the slightest breeze will swing the ship against the hangar, tearing the bag and precipitating an explosion. The mooring mast shown in the above illustration is designed to obviate future accidents of this type. The mast is built in four sections and, when extended, moors the ship in

the air. To place the vessel in the hangar, it is only necessary to drop the mast as shown, drop hawsers from various parts of the ship to the car seen in the rear of the illustration, pull the ship down and move the collapsible mast and the rear car into the hangar with the ship in tow, as both the mast and the car run along tracks. This idea is that of Mr. Wm. P. Sullivan.—Ernest Brennecke.

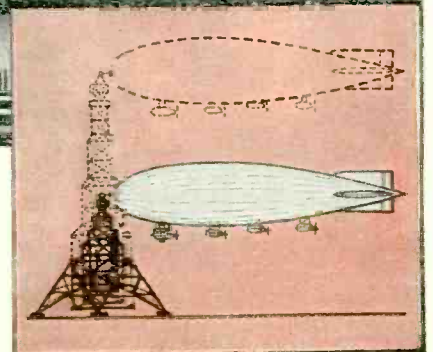

# Cigar Lighter and Help for Autoists

Matches Used Instead of Liquid in Novel Lighter

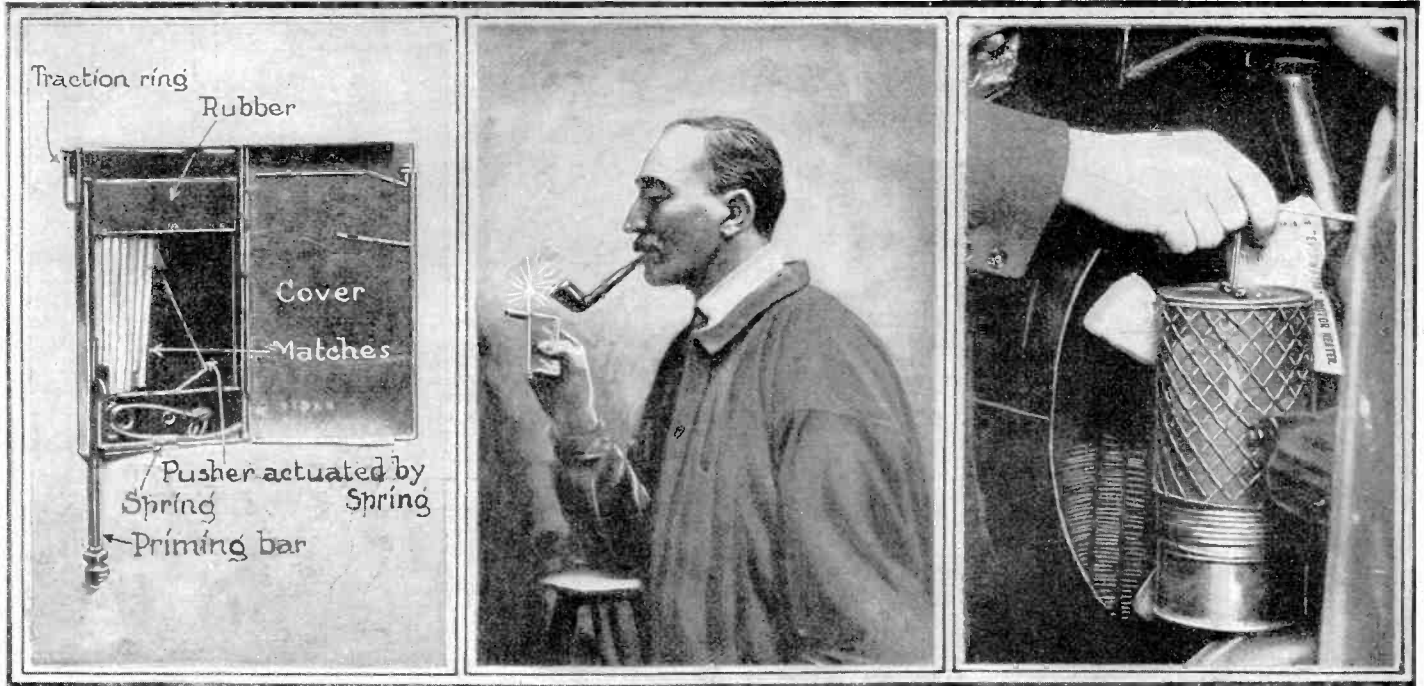

In the two photographs at the left are shown the latest invention of a Frenchman, designed for the more complete pleasure of the smoker who is more or less an Epicurian. Many smokers do not like the flavor of a gasoline flame found in the automatic cigar lighters, so the ingenious Frenchman has designed the lighter shown, which has all the advantages of the mechanical device with none of its inconveniences. By simply pushing a small

plug at the bottom of the box a match is forced up, lighted and held in place for the smoker. Regular safety matches are used to charge the lighter. At the right is shown the latest method employed to keep cars from freezing in cold weather. It consists of nothing more than a small lamp placed between the front of the motor and the radiator. In cold weather it is turned on whenever the car stands with the motor dead.—L. Fournier.

## Blood Circulation System Models

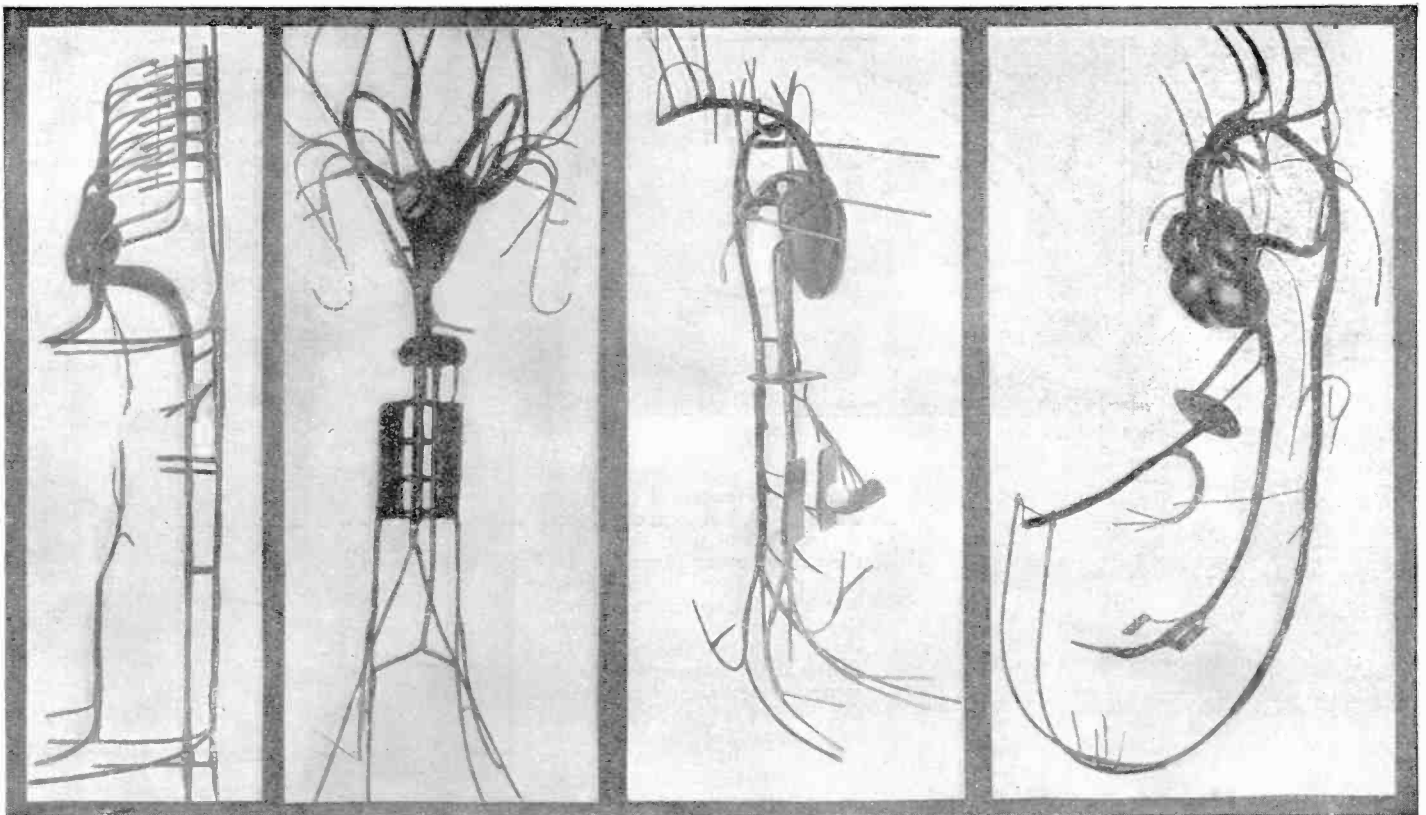

In the illustrations above are shown several models, constructed of gypsum and wires by the famous German technician, Miss Agnes Erfurt of the University of Frankfurt, of the blood circulatory systems of a number of animals and fishes. As shown above, small wires are used as the foundation upon which to build the models. Upon these small wires the gypsum is placed in such shape and size as to conform to the exact dimensions of the

original or in a certain fixed relation thereto. Each part of the system is colored so that it may be more easily traced out by the student. Left to right the models show: (1) Blood circulation of the shark. (2) Model of the blood circulation of a frog. (3) Model of the circulation of blood in a rabbit. (4) Model of the human placental blood circulation after a natural preparation by Professor Hertwig.—Dr. Albert Neuberger.

# Flyers Skim Top of Hawaiian Volcano

By LT. C. P. McDARMENT

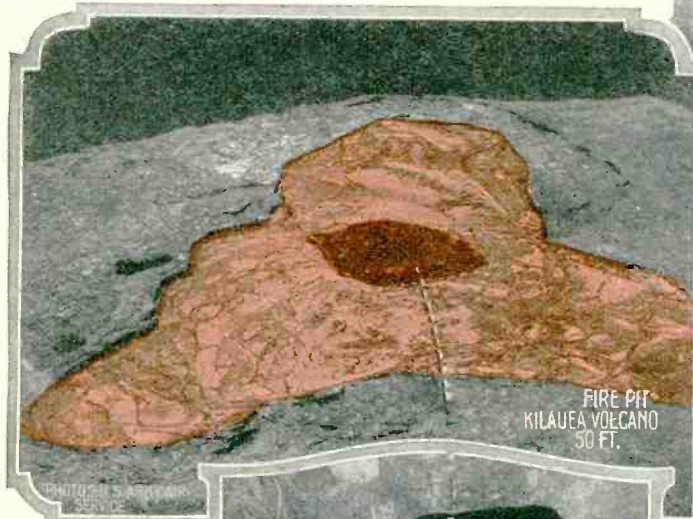

FIRE PIT  
KILAUEA VOLCANO  
50 FT.



FIRE PIT  
KILAUEA VOLCANO  
4,000 FT.

The top of Kilauea is one flaming, boiling mass of molten rock. In the very center there is a cone of actual incandescent rock, which boils up and recedes, according to the pictures and investigations made by two U. S. Army flyers; these movements follow closely the tides. The flyers skimmed across just fifty feet above the crater.

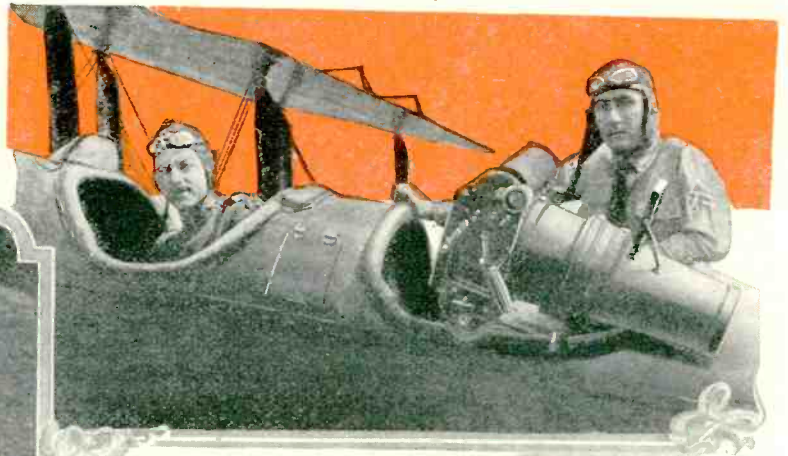

Above is Lieutenant R. C. Wriston and Sergeant R. L. Agnew of the U. S. Air Service, with the camera and plane which they used in making the pictures and investigations given here. They flew with all possible speed.

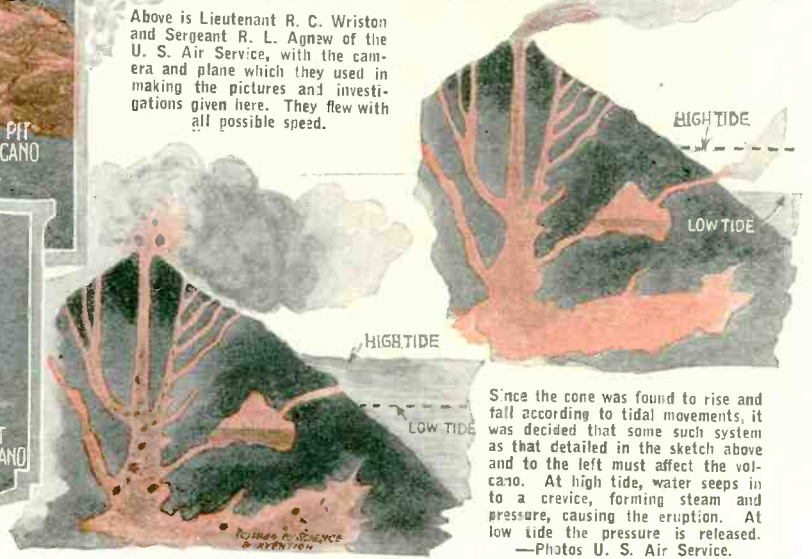

HIGHTIDE

LOW TIDE

HIGHTIDE

LOW TIDE

Since the cone was found to rise and fall according to tidal movements, it was decided that some such system as that detailed in the sketch above and to the left must affect the volcano. At high tide, water seeps in to a crevice, forming steam and pressure, causing the eruption. At low tide the pressure is released.  
—Photos U. S. Air Service.

# New York Goes On a Spree

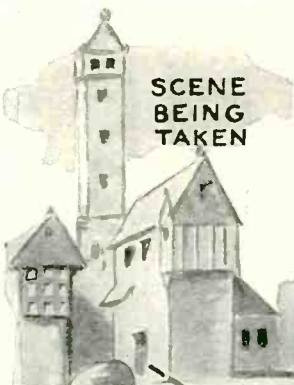

SCENE  
BEING  
TAKEN

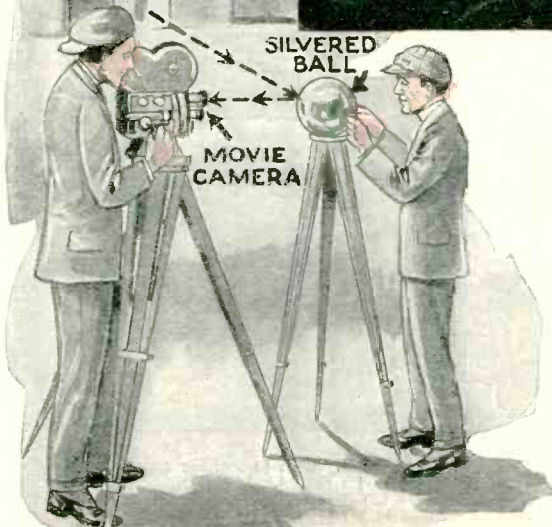
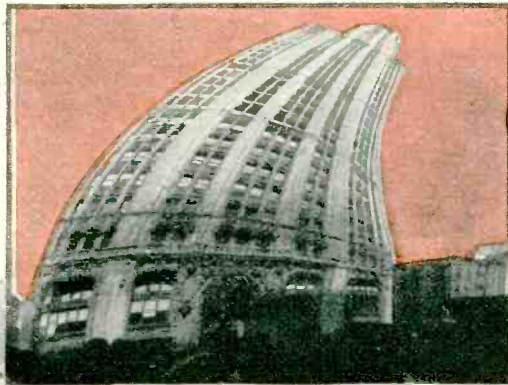

SILVERED BALL

MOVIE CAMERA

Fox News recently gave New Yorkers quite a thrill when they released typical scenes around the city made with the aid of their new "crazy camera." Immediately above is the Woolworth Building taken through this system, and at the right above is the camera-man. The sketch at the left shows how the scenes were taken by pointing the camera at a silvered ball and taking the image of the scene as it appeared as a reflection from the silvered surface. The camera-man's portrait was taken the same way.

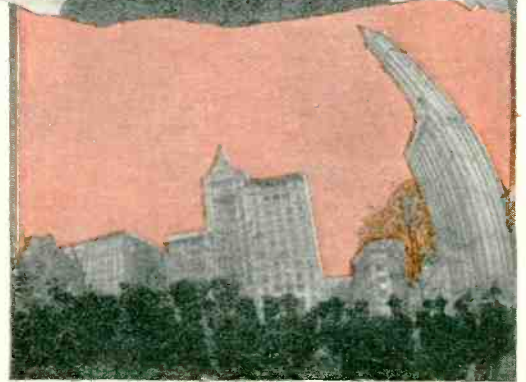

Above is shown a view taken near the City Hall, New York, with the Woolworth Building in the background. All sorts of distorted scenes with moving cars, people and trucks were taken with the aid of this camera, and proved exceedingly amusing.



# European Advances in Science

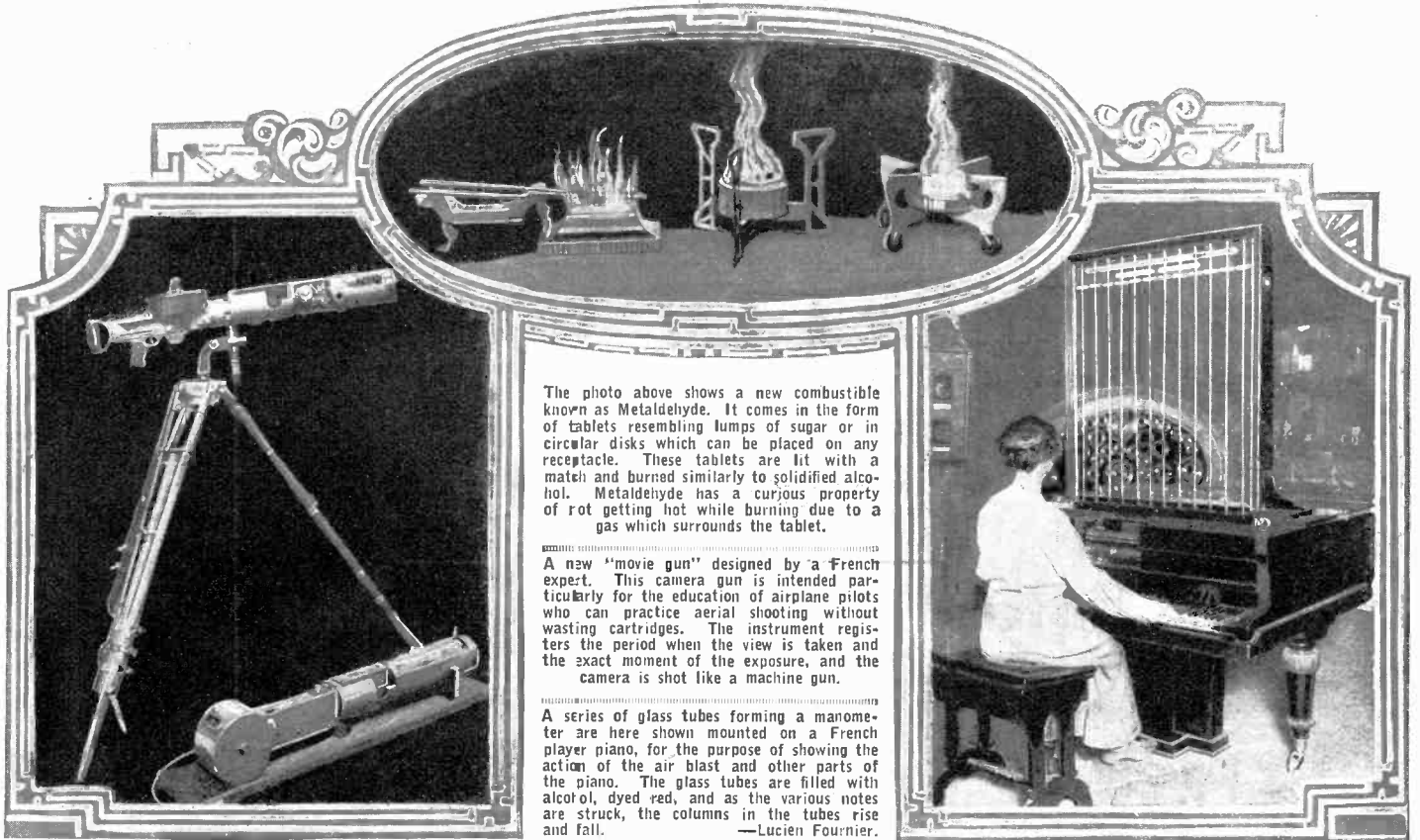

The photo above shows a new combustible known as Metaldehyde. It comes in the form of tablets resembling lumps of sugar or in circular disks which can be placed on any receptacle. These tablets are lit with a match and burned similarly to solidified alcohol. Metaldehyde has a curious property of rot getting hot while burning due to a gas which surrounds the tablet.

A new "movie gun" designed by a French expert. This camera gun is intended particularly for the education of airplane pilots who can practice aerial shooting without wasting cartridges. The instrument registers the period when the view is taken and the exact moment of the exposure, and the camera is shot like a machine gun.

A series of glass tubes forming a manometer are here shown mounted on a French player piano, for the purpose of showing the action of the air blast and other parts of the piano. The glass tubes are filled with alcohol, dyed red, and as the various notes are struck, the columns in the tubes rise and fall. —Lucien Fournier.

## A Super-Sensitive Microphone

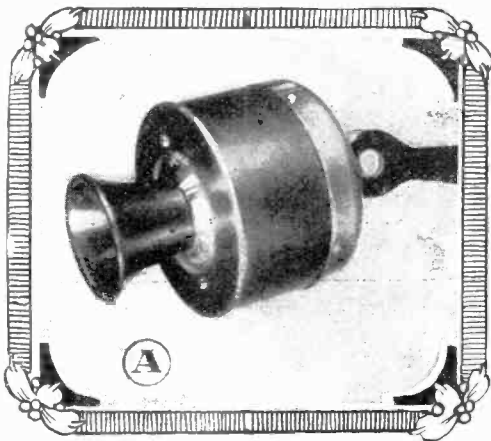

Photos A and C show two views of the new microphone having its sound actuated element moved by inertia instead of impact. —Ernst Keil.

The diaphragm and carbon grain chamber in this new super-sensitive microphone is mounted at the end of a metal bellows.

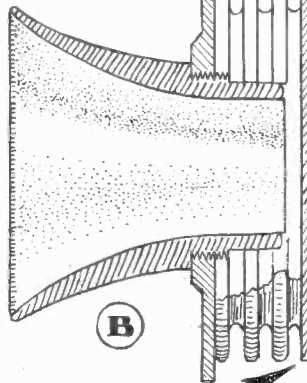

TO CURRENT

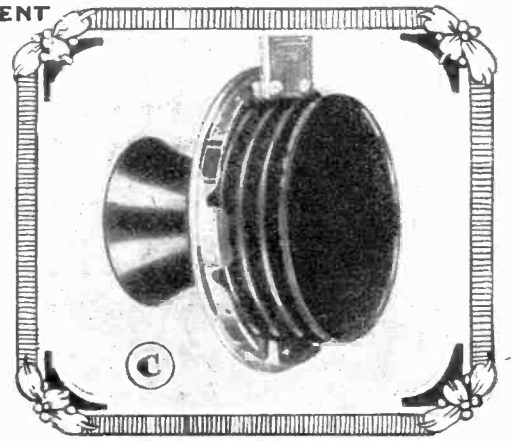

DIAPHRAGM

CHAMBER FILLED WITH GRANULAR CARBON

## Solving Traffic Problem

This is a model of an invention by Sir Alfred Yarrow to relieve congested streets traffic by abolishing the hold-up at cross-roads. It will be seen that by a gentle gradient one stream of traffic passes the other when the point of intersection is reached. The scheme is suggested for the big cities where road traffic is considerable.

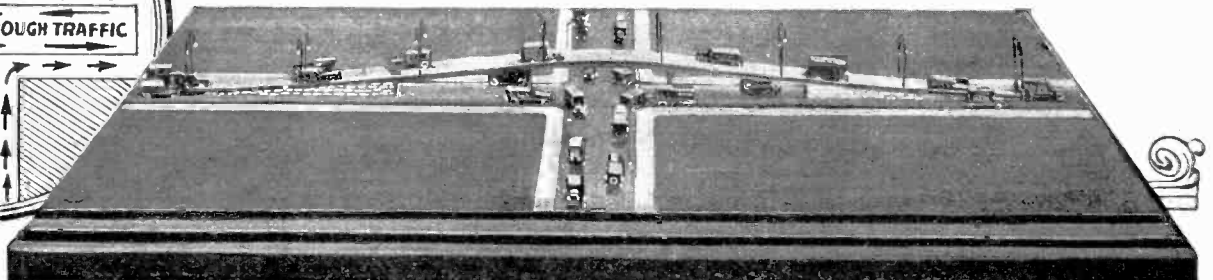
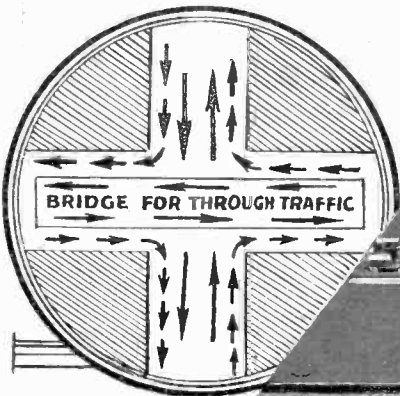

# Rocket Life-Line Anchor

Many of the most disastrous of sea accidents take place near the shore—within sight of help, for there is a great loss of life due to the difficulty encountered in removing the passengers and crew through usually high and rough surf. The invention shown here obviates this trouble and will effect a great saving in life where ships run aground or encounter rocks. It consists of an anchor as shown, to which is attached a life-line. It is fired from the boat with the aid of a rocket and has a range of 1,000 yards.

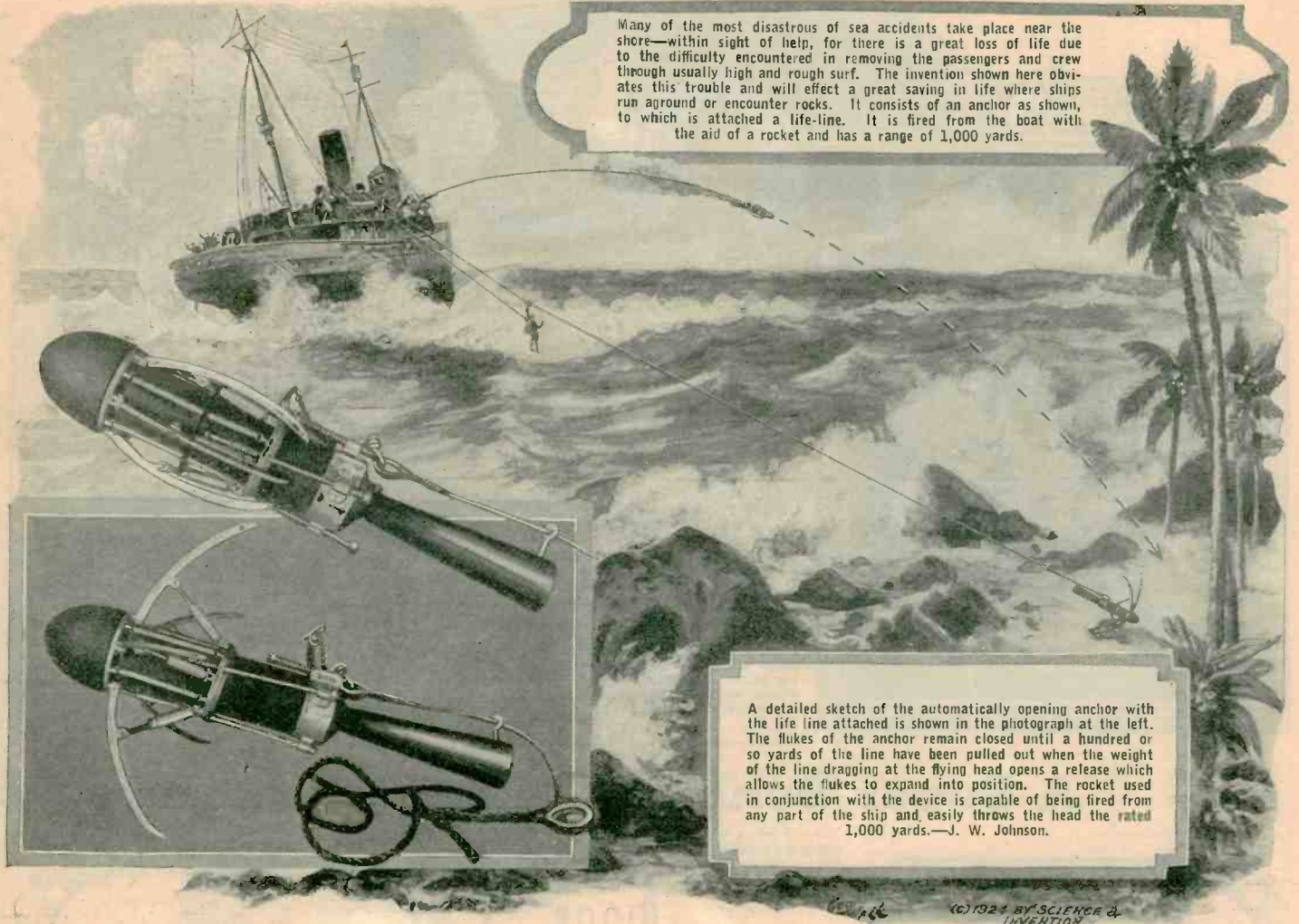

A detailed sketch of the automatically opening anchor with the life line attached is shown in the photograph at the left. The flukes of the anchor remain closed until a hundred or so yards of the line have been pulled out when the weight of the line dragging at the flying head opens a release which allows the flukes to expand into position. The rocket used in conjunction with the device is capable of being fired from any part of the ship and easily throws the head the rated 1,000 yards.—J. W. Johnson.

(C) 1924 BY SCIENCE & INVENTION

## The Oyster's Body

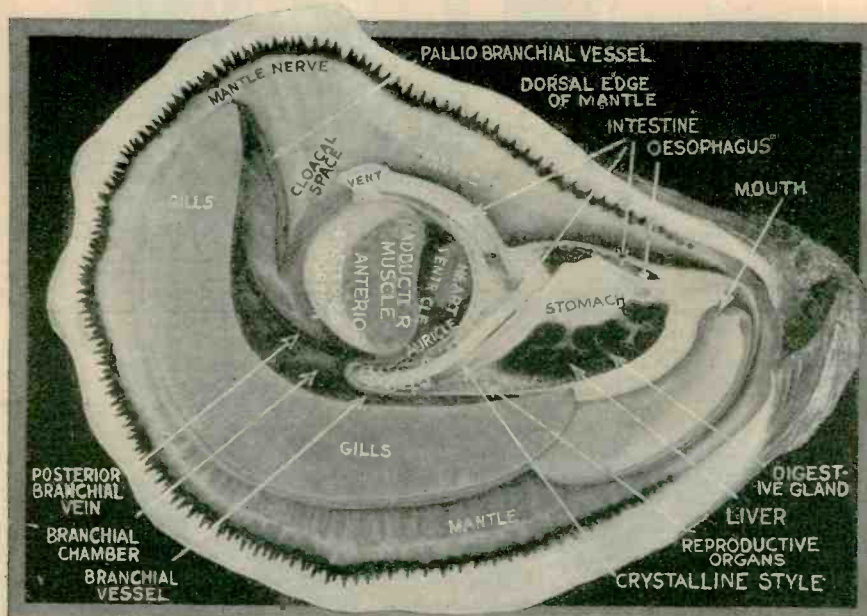

Many think an oyster is not a living animal, at least not like a fish. The sketch above will prove otherwise and leave no room for doubt. Note first the stomach. It is fed from a mouth just as in the case of the fish which live in the water with it. Then there is the respiratory system consisting of gills through which the blood from the heart flows and is purified. Means are also available for carrying away the body's waste.

## Under Water

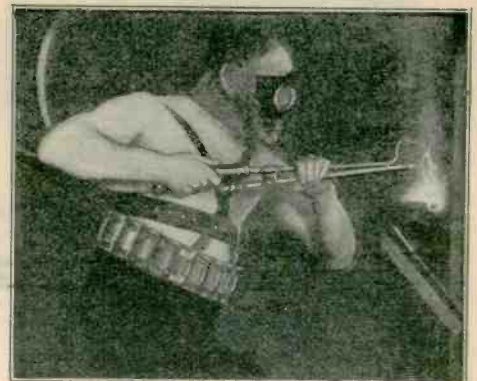

ONE of the most startling demonstrations given at a recent Physics Convention at Paris was the use of an oxy-acetylene torch with the flame and work submerged in water. The operator of the torch boldly thrust the tip of the flame beneath the surface of water and directed it against a steel plate which lay on the bottom of the tank. After a preliminary heating he brought the temperature of the metal to such a point that it would unite with the oxygen fed direct from the torch tip. After the preliminary experiment, a diver equipped with a torch descended several feet below the surface of a large tank and entertained the astounded scientists by cutting all sorts of fancy designs in half-inch steel plates while under the water. In engineering circles it is said that this discovery and adaptation of the acetylene torch is of the greatest importance in salvaging ships and releasing buried treasure which has long been locked in the steel hulls of ships. —Photo—Pure Iron Era.

# Vacuum Finds Many Uses

By H. WINFIELD SECOR, E. E.



Vacuum is very important in incandescent lamps, audions, X-ray and Geissler tubes.

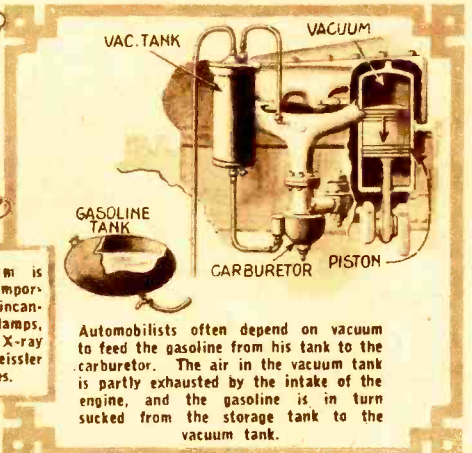

Automobilists often depend on vacuum to feed the gasoline from his tank to the carburetor. The air in the vacuum tank is partly exhausted by the intake of the engine, and the gasoline is in turn sucked from the storage tank to the vacuum tank.

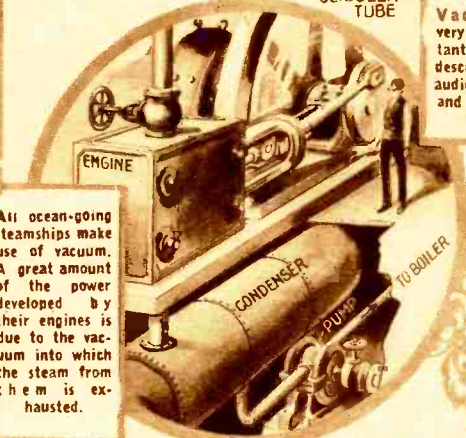

Air ocean-going steamships make use of vacuum. A great amount of the power developed by their engines is due to the vacuum into which the steam from them is exhausted.



Siphons are all operated by the air pressure acting on the surface of the upper liquid against the suction or partial vacuum in the tube.

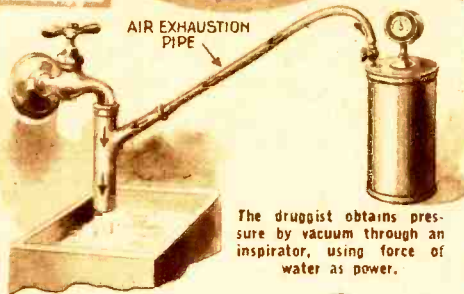
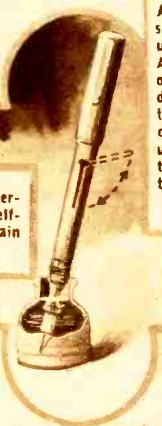

The druggist obtains pressure by vacuum through an inspirator, using force of water as power.

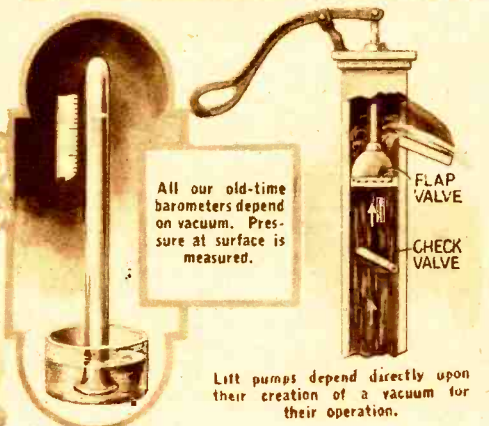

All our old-time barometers depend on vacuum. Pressure at surface is measured.

Lift pumps depend directly upon their creation of a vacuum for their operation.

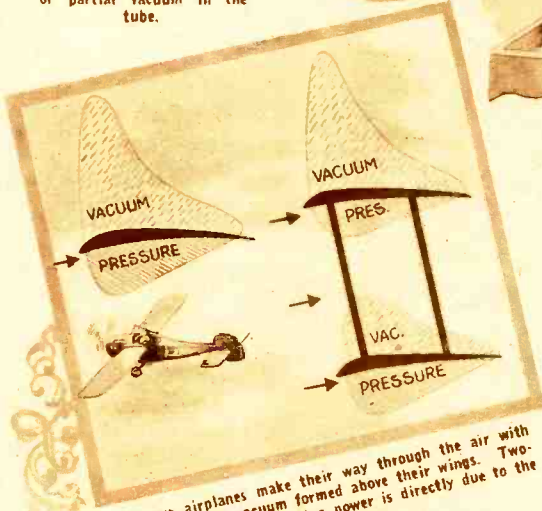

All our airplanes make their way through the air with the aid of the vacuum formed above their wings. Two-thirds of the wing's lifting power is directly due to the vacuum action.

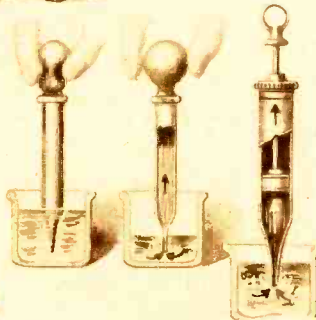

All our simple syringes use vacuum. The air is exhausted by means of a plunger or bulb, so that when it is released, atmospheric pressure drives the fluid into the cylinder.



The vacuum bottles with which we keep picnic drinks warm or cold are a success because the vacuum between the inner and outer walls is a practical heat insulator. The substance in the bottle cannot radiate or absorb heat.



The plumbers lose many hours of work due to the push-pull effect of the device shown above. It utilizes both vacuum and air pressure.

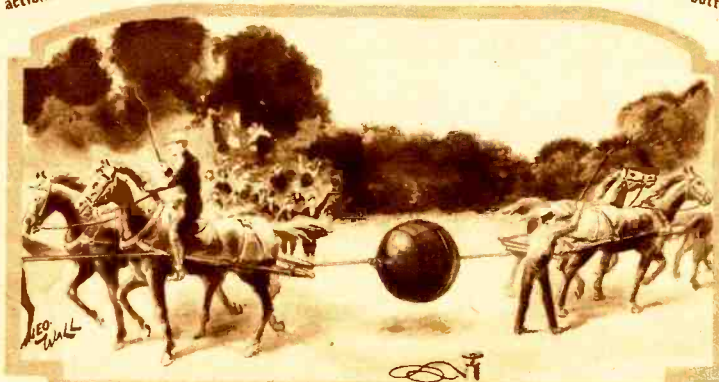

The classical Magdeburg hemispheres experiment shows the force vacuum may exert. Two hemispheres were placed together and the air between them exhausted. Sixteen teams of horses were hitched to each, and with all their strength could not separate them.



Our drinks through straws at the soda fountain are lifted by an air pressure due to a partial vacuum.

# The Man On the Meteor

By RAY CUMMINGS

Part IX

(Conclusion)

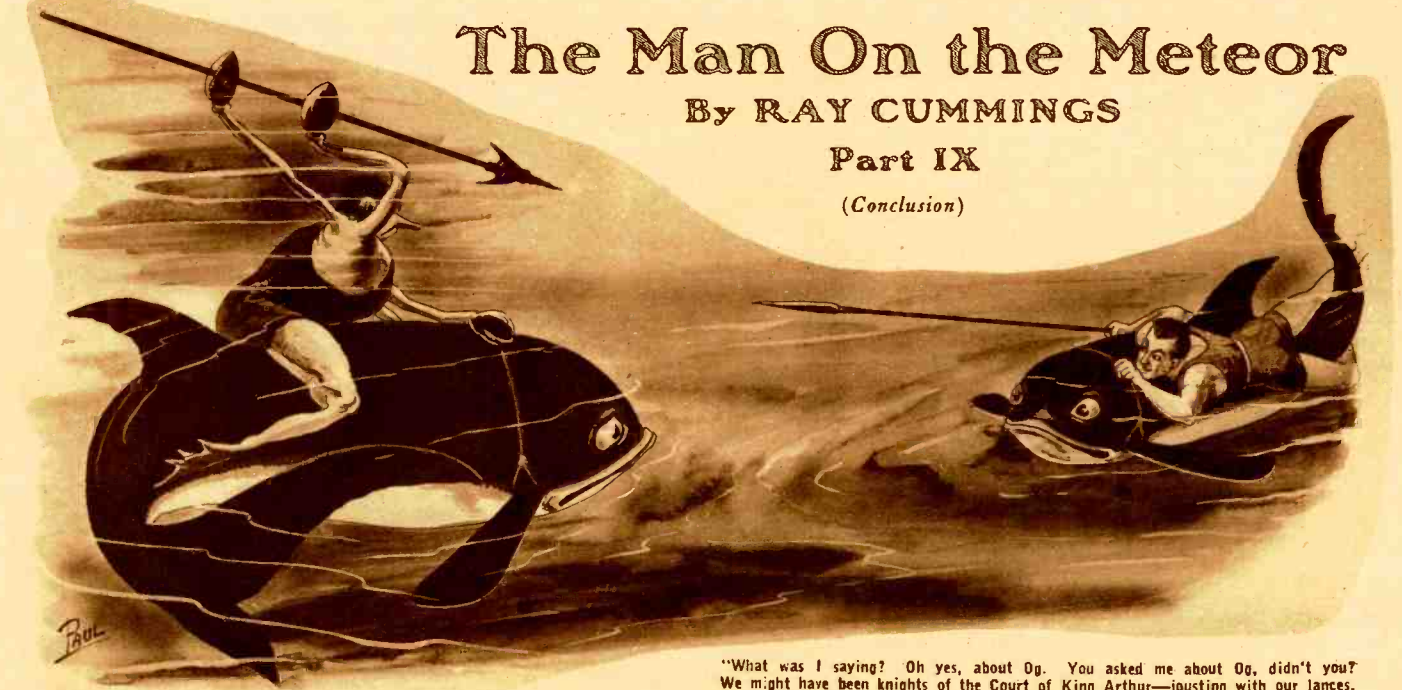

"What was I saying? Oh yes, about Og. You asked me about Og, didn't you? We might have been knights of the Court of King Arthur—jousting with our lances. I can remember it now—clearly. I would have run him through almost at the first tilt, but . . ."

WITH no memory of past events, a young man suddenly comes to his senses on a meteor which is part of one of the rings of Saturn. He looks for nourishment and finds the mouth of a cave. As he looks toward the cave a girl comes into view. One day, upon returning to the cave, Nona, the girl, shows Nemo, as the man calls himself, several mollusks which make good food. To gather more of this food, they wade into a stream. Nemo sees Nona's head is completely engulfed. Soon his head goes under water and he feels the liquid rush into his lungs. However, by violent effort he is able to breathe the water.

Later they see coming toward them a party of ten people, four men and six women, who are somewhat human in form, but have four arms like the tentacles of a cuttlefish. Nemo and Nona are captured and tied by them.

They are taken by the Marinoids, as the members of the party call themselves, to the city called Rax. This city is built in the stream of underwater vegetation.

A man named Og insulted Nemo and challenged him to a fight. The fight took place in front of the palace of the ruler and Nemo was defeated because Og had a peculiar property, which was characteristic of the Marinoids, enabling him to send a charge of animal electricity into the body of Nemo, thereby rendering him unconscious.

For a year things go along peacefully, when suddenly the daughter of a Marinoid family disappears. This is repeated again and again until thirty of the young women of the city were stolen. Later Nemo saw a strange figure in the street. Suddenly all light is obliterated and Caan and Nemo, swimming through the darkness, find a woman unconscious, shocked into insensibility by animal electricity. Nemo comes to grips with the man attempting to abduct the woman and finds it to be his old enemy Og. Nemo returns to his home to find that Nona is gone.

The Water of Wild Things, an unknown stretch of sea, is the home of the tribe doing the kidnaping. An expedition is organized to bring the stolen girls back, and led by Atar, the king's son, they go into the Water of Wild Things. Atar, Nemo and Caan penetrate a barrier of vegetation, which guards the entrance, descend the side of a perpendicular cliff and soon see lights in some sort of a dwelling place. They enter the place and find it to be crowded with other people. Og is seen talking to them and on a raised platform is Nona.

Og declares his love for Nona to the people and says that he will lead them to victory over the Marinoids and that Nona will be their Queen. One of Og's lovers becomes jealous and protests. She is waved away and suddenly returns with a dagger to kill Nona. Nemo interferes and releases Nona. They start away from the Water of Wild Things.

Later in the day, through the aid of Og's jealous lover, Nemo with Nona and the remainder of the party, make their escape, after learning that Og, as leader of the tribe who call themselves the Maagogs, plan to make war on Rax and capture the city. The party on returning home tells the king of their discovery who begins preparations for war.

There is a season of merry-making after the war has been announced to the Marinoid citizens. During its course a half-breed hurls a needle fish in an attempt to kill the Marinoid King. A Marinoid girl thrusts herself in the fish's path, saving the King's life. The Prince and Nemo make a reconnoiter to a neighboring city and find that the half-breeds within the kingdom have already begun a massacre. The war is on!

I LED my army out of Rax. The details of its organization I had left to Atar and Caan, while Nona and I were on our expedition to Gahna. They had done their work well; and within an hour after our return we were ready to leave—to face the advancing Maagog forces.

We left from the roof of Rax. The broad, open space there was ample for mobilization, and in the center of it my forces were gathered. You of a greater civilization, might call this army of mine meagre. Yet to us Marinoids it was huge—the largest group of fighting men these people had ever conceived of organizing.

Some two thousand men, girls and dolphins—the product of all the Marinoid cities and the rural population. We had many more who wanted, and were able, to join us. But these I left at home—some in Rax, some in the other, smaller cities. So that at home—in the event of disaster to our fighters in the open water—we would not be quite defenceless.

An army of two thousand! It was not very much, of course; but it was equipped and organized—with a plan of action which

I shall tell you in a moment. That it would be ample for victory, I did not doubt. Og and his Maagogs might outnumber us—of that I could not say. But we had fighting qualities which the slow lumbering Maagogs could not possibly equal. We would be easily victorious, I thought; but Nona was not so sanguine.

In spite of my commands the people of Rax, many of them, had gathered on the city roof to see us leave; a circular fringe of them jammed the edge of the roof, waiting to cheer our departure.

But they did not cheer. With solemn faces they stared upward at our columns as we rose into the water—women staring after their husbands and sons, even their daughters—women and old men staring, and wondering which of their loved ones would return alive to them.

In command of the entire Marinoid forces, I rode alone on a dolphin—with hands free and with only a lance fastened flat against the dolphin's back and a dagger in my belt. I was first off the roof of Rax. As I rose, gliding smoothly upward and outward, I looked down to see the city dropping away.

## THE ARMY STARTS

A column of young men, swimming five abreast, came up next—like birds rising in orderly array to follow their lone leader. It was an inspiring sight—this sinuous, curving line of swimmers. It swung into the water, bent like a huge rainbow over the city, straightened, and followed me diagonally upward.

Soon Rax had dwindled small and dim in the water below. But I could see Nona's forces—the girls mounted on dolphins—as they too were starting. Then Rax, now so far beneath me, blurred and was lost in the gray-green haze of water; and I turned my attention ahead.

The back-bone of my army was the line of young men swimming five abreast behind me. Five hundred of them there were—young, powerful swimmers—youths at the height of their physical strength. Each was by nature capable of shocking into insensibility with an electric discharge, any opponent he could touch by head and heels simultaneously.

These young men were unarmed; I felt that they could use their natural weapon to better advantage when swimming free-handed.



Then I shouted my command, and we started vertically downward—our first attack upon the enemy.

Nona's corps consisted of some two hundred girls mounted on dolphins. Each with a long, lance-like spear in her hands. Nona commanded them—with ten extra girls, each to control a group of twenty.

Then there was Atar's corps of sleighs—the "light-sleighs" which I have already described. Atar himself had a dolphin mount. In each of the ten dolphin-drawn sleighs was a single occupant—an older man. These sleighs I would use to precede us—to throw light upon the enemy, blind him, and cover our onslaught made from behind.

The "sleighs of darkness"—ten of them, dolphin-drawn, and each with two occupants—were commanded by Caan, himself riding a separate dolphin. These sleighs were for darkening the water in the event of a catastrophe to our fighters—to cover our retreat wherever it might be necessary.

**THE ELECTRIC POWER**

For the rest, my main forces were a thousand fighting men—older men in whom the electric power was waning. They were armed with various types of spears—daggers, javelins and lances. They were leaving Rax in a long swimming line some ten abreast.

Such was my army which now was following me into battle. I led it upward. Behind me I could see the long columns of swimming figures—the sleighs in two broad groups—the girls on the dolphins in squads of twenty, each with its leader apart.

Ahead of me lay open water—a gray-green in the half-light, dim and blurred. Far overhead I knew was the rocky ceiling which marked the top of this watery, subterranean world; and the ooze and sand of the sea-bottom was perhaps two thousand feet beneath me.

I was heading for Gahna. The water here was almost free of vegetation, but not wholly so. Occasionally thin, waving spires of seaweed, covered with air-pods to sustain them, reared their heads. I threaded my way among them; and with every turn I made the line of swimming figures behind me followed.

Soon I conjectured I must be half-way to the former site of Gahna. The Maagogs would probably follow the sea-bottom in their advance, for they were all indifferent swimmers, flabby of muscle and short of breath. It was time for me to descend and locate them.

I waited—as it had been pre-arranged that I should wait at this point; and as I hung poised in a broad stretch of empty water,



Our light-sleighs were of little use here; hastily we sent them speeding upward, to bring down our main army to our assistance. Atar and I on our dolphins circled about. The black fishes were everywhere; confusion again; the lashing figures of our young men as they met the black, ugly little things—all jaws, and teeth like needles.

my army swung up and gathered. In two huge concentric circles, the men swam slowly around me, while the girls on the dolphins moved lazily back and forth above and below.

A beautiful sight, these girls—slim bodies clinging closely to the sleek backs of their graceful mounts. And Caan and Atar with their squads of sleighs holding motionless on the outskirts.

In the center of it all, Nona rode her dolphin to join me.

"We are all ready, Nemo." And she laughed gaily; though searching her face, I could see no laughter in her solemn eyes.

I told her then to wait while I went down to the sea-bottom to locate the enemy. She nodded; and I left her.

Slowly I drove my dolphin around the circle of my men—shouting a word of en-

couragement here and there. I consulted a moment with Caan and Atar; waved at Nona as I passed her again, and dove my mount downward.

The ring of waiting figures above me faded into dimness and were lost. I was alone in the water.

It took but a few moments to reach the bottom; it came up to me, by optical illusion tilted vertically on end. A hundred feet above it I righted my mount.

I was over a level floor of sand, with cactus-like growths here and there. Empty; there was no sign of Maagogs.

Ahead of me, in the direction of where Gahna had once stood, I saw the shadows of a forest. I advanced toward it; and from it were emerging the first lines of the oncoming enemy.

**THE COMBAT**

But my heart sank. There were very many of them.

At once I raced my dolphin upward. And my thoughts were racing also. Again I had lost another opportunity for ambush. Had we reached the forest before the Maagogs began to emerge, we might have surprised them there. The forest was several miles long and a mile broad perhaps, in the horizontal direction from Gahna to Rax. A mile of thick vegetation—tree, spires and a tangle of vines and weeds rearing themselves several thousand feet up into the water. The Maagog army was now traversing that mile-width of forest. Perhaps, if I could cut them off in there—attack them piecemeal as they emerged.

I was again with my own forces. Nona, Atar and Caan rode their mounts hastily to meet me, and I told them the situation.

It took us but a moment to decide. We would maintain this upper open water as our base. I ordered Atar with his light-sleighs and half of our electric fighting men, to follow me down. I would attack these first columns of the enemy as they came out of the forest.

Nona, with her girls, was to ride swiftly above the forest, descend on its other side and drive the last of the Maagogs in. We did not want any of them to retreat toward Gahna.

I waited, while Nona with the dolphins dashed upward and away. The girls had all been flushed and eager; but as they swept by me in a line I saw that each little face was white, set and grave.

(Continued on page 511)

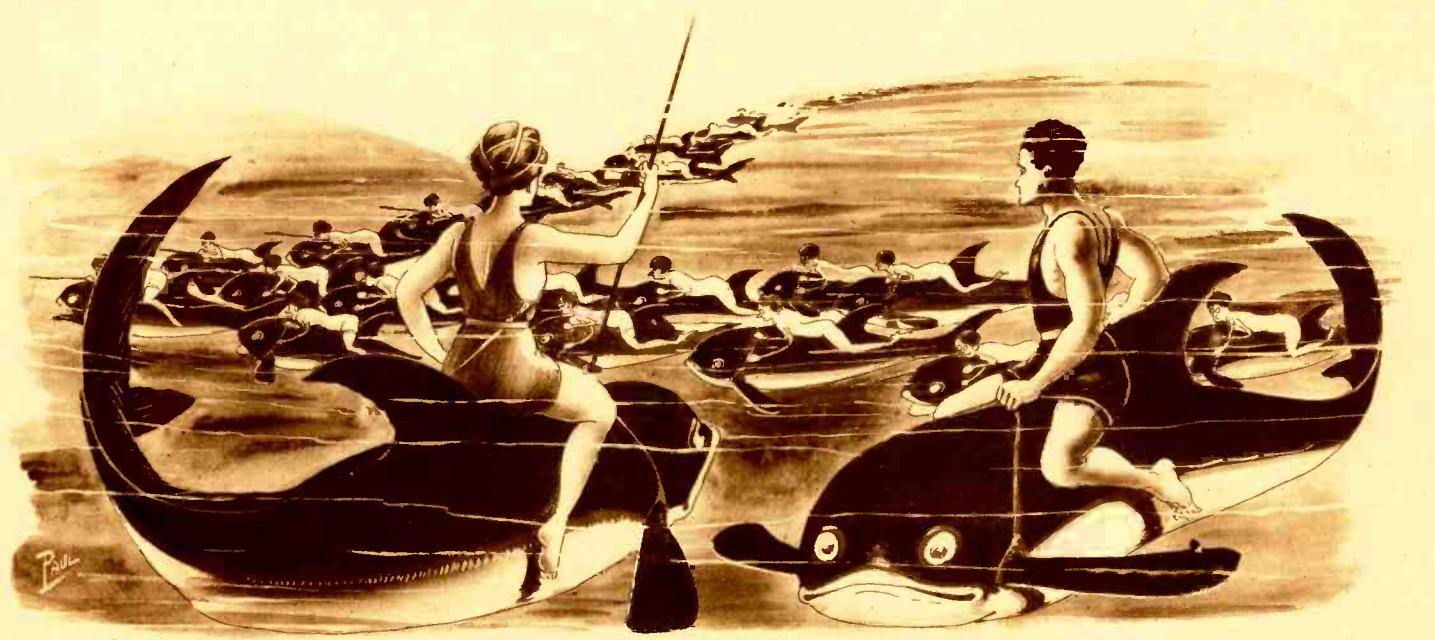

Nona's corps consisted of some two hundred girls mounted on dolphins. Each with a long, lance-like spear in her hands. Nona commanded them—with ten extra girls, each to control a group of twenty.

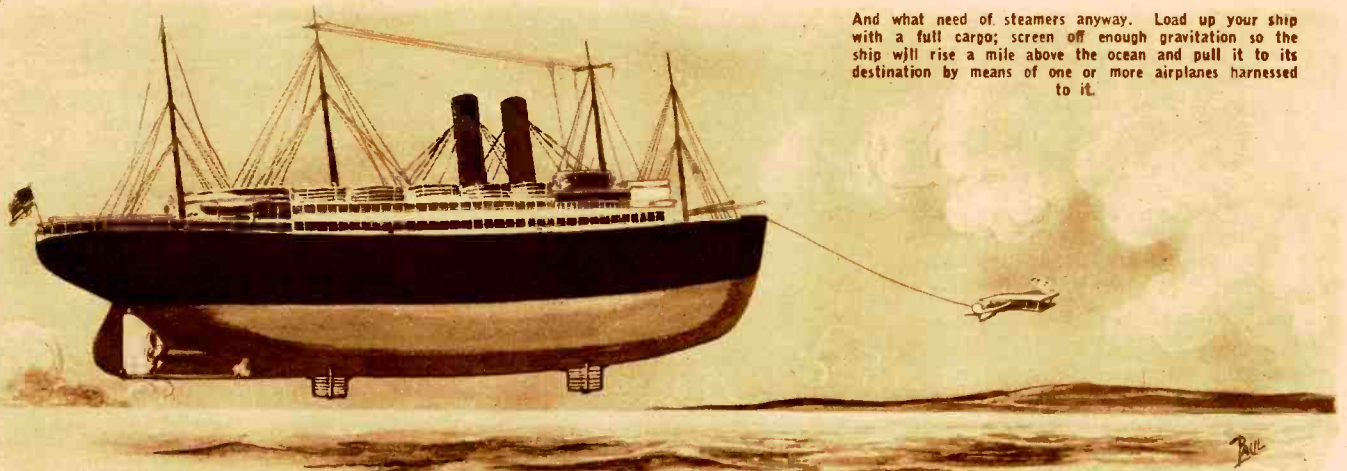

And what need of steamers anyway. Load up your ship with a full cargo; screen off enough gravitation so the ship will rise a mile above the ocean and pull it to its destination by means of one or more airplanes harnessed to it.

# Doctor Hackensaw's Secrets

By CLEMENT FEZANDIÉ

*(Author's Note Man is able to reflect Sound, Heat and Light. All analogy leads us to believe that gravitation is a form of energy closely allied to sound, heat, light and electricity. Hence it should be possible to find some means of screening it off, so as to preserve bodies from the attraction of gravitation. Such a screen or reflector could be made use of in many ways.)*

## CHAPTER I

"SILAS," said Doctor Hackensaw, "I've got something to show you today, that, in certain respects, beats anything I have yet accomplished. In fact it opens up entirely new fields for investigation, and there is no telling to what it may lead us. Silas, I have found the means of reflecting gravitation!"

Silas Rockett's face fell. "Oh, is that all!" he exclaimed in a tone of contempt.

"Ah Silas," returned the doctor, "I see you don't realize the transcendental value of the discovery, but its practical bearings are simply immense. To take but a single example, all our methods of transportation will be revolutionized since we can deprive objects of their weight at will, and blow them around to their destination by suitable air-currents. Just think, every man can carry around his own airplane in the form of an umbrella made of 'radaluminium'; that, by the way, is the name of my new metal. When the umbrella is opened, you will rise in the air, and a propeller worked by bicycle pedals will carry you wherever you wish to go. Why, man, the air will be crowded with these aerial bicycles and the traffic policemen will have their hands full attending to them!

"You mustn't believe that my investigation was an easy one. I attacked the problem from many different points before I finally met with success. You are perhaps aware that the scientist Majorana, from the result of certain pendulum experiments, concluded that a mass of lead, surrounded by mercury, exerted less gravitational force than when not so surrounded. This seemed a clue, but after hundreds of experiments with lead and mercury I was no nearer my goal than before. Next I tried 'interference.' As you probably know, two sounds, by interference, may be made to destroy each other and produce silence. Two lights may likewise extinguish each other and produce darkness. It seemed logical to believe that two attractions could likewise be made to interfere and neutralize each other. Unfortunately I had no attractive force at hand with which to neutralize that of the earth. Then I thought of magnetism. Magnetism and gravitation must be

## No. 32. The Secret of the Gravitation Screen

fundamentally alike. If I could find means of reflecting magnetism, the same substance would probably screen off gravitation.

METAL LIGHTER THAN AIR

"Now, as you know, I have discovered

**T**HE annihilation of gravity always gives food for thought. Suppose you had this marvelous gift placed in your hands—what would you do with it? Some of the possible and impossible things which you could do with a Gravity Eliminator, such as related by Mr. Fezandié, are described interestingly in the accompanying story, wherein the principal actors are Dr. Hackensaw and his friend Silas Rockett, the village cut-up, who has become a reporter for an important metropolitan daily. Don't fail to read about Mr. Rockett's startling experiences.

aluminum entered into its composition. I had made only about one gram of this metal, but had been astonished at its lightness, for it floated above the air in the retort, and when released, flew up to the ceiling of the laboratory. So I turned my attention to manufacturing this radaluminium on a large scale. Luckily my first experiments were cautiously made, else I shouldn't be here to tell the tale, for a ball of the new metal, as it rose, broke the glass retort and shooting like a bullet, passed through the ceiling and up into the sky. That made me more cautious. I saw I must produce this metal in small particles and afterwards fuse these particles together with proper precautions.

"I won't bore you with the details of my experiments. Suffice it to say, I discovered that I must cast my gravitation screens in thin sheets in the form of wheels with plenty of vacant space between the metal-spokes, as in the diagram shown.

"By placing a heavy weight on these sheets they could be kept from flying up into the sky.

"By using several of these sheets one on top of the other and revolving them so as to shut off more or less of the earth's gravitation, I could regulate at will the weight of the substance above the screen. When all gravitation was screened off, the whole apparatus would rise up into the air; if properly ballasted below, so as to remain horizontal in the ascent.

"That stuff would make a dandy car for traveling off to the planets," suggested Silas. "Shut off the earth's attraction and let in that of the sun or any other heavenly body you wished to visit, and away you'd go!"

hundreds of new chemical combinations, alloys, allotropic forms of matter and even new elements. Among these there was a new metal, lighter than air, and which I had called 'radaluminium' because radium and

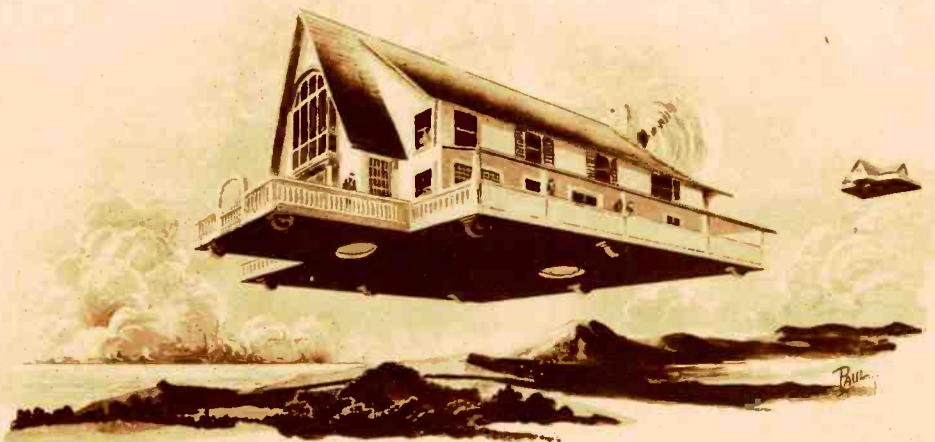

Then, too, think of the advantage of my gravitation screen to architects and others. You can carry a house from one city to another through the air. The house-trust can manufacture houses by the thousand in one spot, using efficiency methods and quantity production.

"Indeed," said Doctor Hackensaw, smiling. "You seem to forget that attraction varies inversely as the square of the distance. To us here, the moon's attractions is greater than that of any other heavenly body, but even that would be almost imperceptible. Gravity on the surface of the moon is 2.65; that is to say a body falling near the surface of the moon would have its velocity increased 2.65 feet each second. As the moon is only some two thousand miles in diameter, such a body would be only one thousand miles away from the center of attraction while the earth is 240,000 miles away. In other words, the greatest pull we could obtain for the car from any heavenly

body would be  $\frac{S^2}{R^2} = \frac{2.65}{X}$  in which S is the



However, he soon got beyond the limits where the air had any appreciable effect on the car's flight. Then the last vestige of his weight left him and he found he could swim about in the air or somersault around in the car in a way that would have made a circus acrobat green with envy.

distance of the moon from the earth, R the radius of the moon, and X the required attraction of the moon on the car. Work it out and you will find that the pull of the moon on the car would be such a small fraction of an inch the first second that the slightest resistance would prevent the car from ever starting at all. And if it did start, it would take hours to go the first few miles."

"But you could give the car a push to start it," suggested Silas.

"True, but that would not be necessary, as you will see for yourself when you try on my anti-gravitation shoes."

## CHAPTER 2

### THE ANTI-GRAVITATION SHOES

Doctor Hackensaw led Silas into the center of a large open field. There stood a table firmly tied down to the solid rock beneath by heavy chains.

Clamped to the top of the table were a pair of clumsy-looking shoes resting on their sides.

"There, Silas," said Doctor Hackensaw, "those are my anti-gravitation shoes. Just lie down on the table and I'll fasten them to your feet."

"Why can't I stand up to put them on?" asked Silas.

"Because the time for you to fly up to heaven as an angel hasn't arrived yet! Be a good boy and do as you're told."

With a groan, the reporter lay down on the table and Doctor Hackensaw fastened around Silas's body a metal frame-work held by a strong chain wound on a windlass. Then the doctor securely buckled the shoes on Silas's feet, and after placing himself in a cage anchored to the ground, he called out:

"Are you all ready?"

"Ye-es," replied the reporter, somewhat dubiously.

With a chuckle, Doctor Hackensaw pressed a lever, and the table tilted so as to bring Silas standing on his feet. At the same moment the clamps that held the shoes to the table were released. Then came a terrific blast of wind and Silas found himself jerked off his feet and carried high up into the air, suspended head downwards in his flight. The chain of the windlass unwound until about thirty feet were out, and then stopped.

"Hi! Pull me down, quick!" cried Silas. "I can't stand this! All the blood's rushing into my head!"

"All right," replied the Doctor, and a pull on a second lever started the windlass at winding up the chain, pulling Silas to the ground and clamping the shoes down to the table again.

"Whew!" cried Silas, as he wiped the beads of perspiration from his brow, and smoothed his ruffled clothing, and still more ruffled temper as he thought of the ridiculous position in which he had been placed.

"Why didn't you warn me of what was coming? It's a blame-fool invention anyway, and there's no money in it. All you could do with it would be to use it in some Coney Island amusement resort. That's about the only place where you could find people willing to pay out good money for an experience like mine."

"Don't take it to heart, Silas," said Doctor Hackensaw, soothingly. "It was even worse



for me the first time I tried it. Luckily, I had taken all my precautions."

"But what in the world started me off so?" demanded Silas. "You said the moon wouldn't pull me up."

"It wasn't the moon," explained the doctor, "it was the wind."

"The wind? What do you mean?"

### GRAVITY RUNS RAILROAD

"Why our atmosphere weighs fifteen pounds to the square inch. In the sole of each of these shoes is a very thin sheet of radaluminium. So long as this metal was vertical, it created almost no disturbance in the atmosphere. But as soon as the soles of the shoes were horizontal, they cut off the earth's attraction from the entire column of air above them. The pressure of the surrounding air forced this column up, and the new air losing weight in its turn, a strong wind arose which would have carried you up into the sky if you had not been securely held down by the chain. Silas, this invention of mine is going to revolutionize transportation. I'll show you how simply people and cars can climb over mountains at practically no expense."

So saying, the doctor drew his note-book from his pocket and made a rough sketch.

"There," said he, "is a track going up one side of a mountain side and down on the other side. P is a passenger or a car held to the track by the rod C. A double wheel W at the lower end of the chain is free to roll along the track, the whole being grooved so as to run on the rail."

"The passenger has on his shoulders a knapsack containing the anti-gravitation metal. A knob outside of the knapsack enables him to shut off as much of the earth's attraction as he desires. When he turns the knob he becomes lighter and up he soars following the track to the top of the mountain. There he reverses the knob, letting in more of the attraction, and as he becomes heavier he slides down the other side. Not a cent to pay for fuel or power of any kind. Gravitation does all the work. Merchandise can be transported for practically nothing, for of course a car can be carried as easily as a passenger. No more shall we be obliged to make our roads level—a road with ups and downs will be far

With a chuckle, Doctor Hackensaw pressed a lever. . . . At the same moment the clamps that held the shoes to the table were released. Then came a terrific blast of wind and Silas found himself jerked off his feet and carried high up into the air, suspended head downwards in his flight. "Hi! Pull me down, quick!" cried Silas. "I can't stand this! All the blood's rushing into my head!"



(Continued on page 500)

# Wonderful Old Roman

By CHARLES



At the left above is a comparison of the bath with the Statue of Liberty. Below is the famous Pine Cone, which stands in a half dome building overlooking the beautiful Vatican Gardens. From each of the petals a stream of water issued. It originally stood on an island centerpiece in the midst of an artificial lake of the Campius Martius. Around it was a whole bed of artificial flowers and plants wrought in bronze. The Pine Cone is still in perfect condition, though it is no longer the centerpiece of a fountain. Some of the flowers have also been retained.

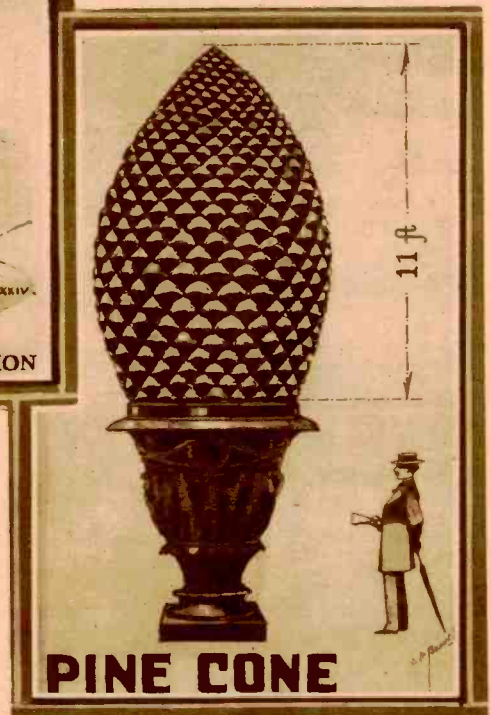
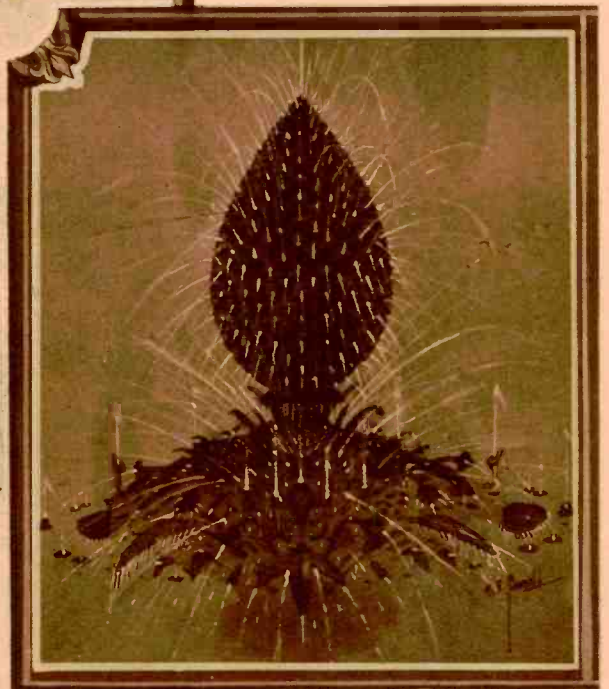
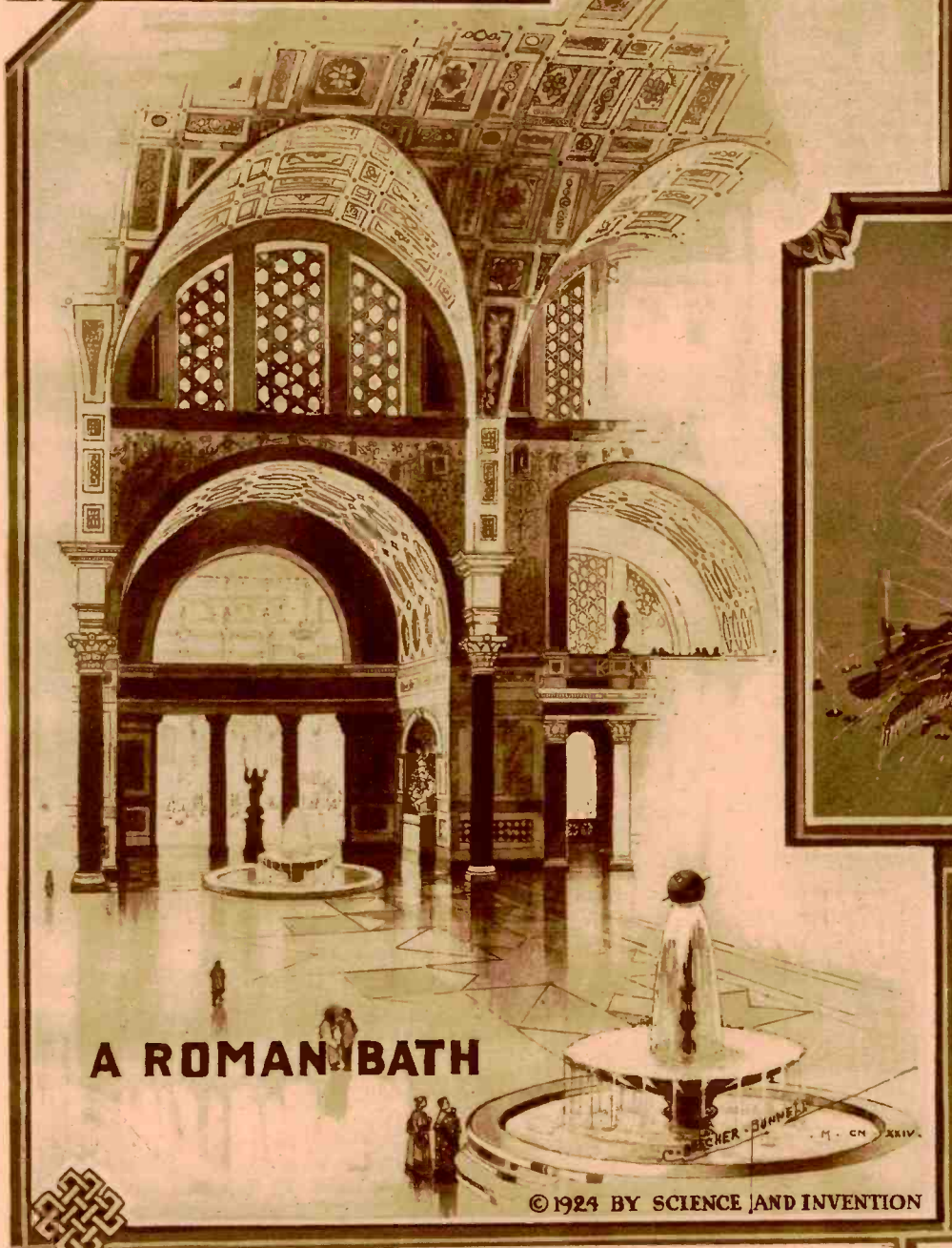

**A ROMAN BATH**

© 1924 BY SCIENCE AND INVENTION

Not only do the Roman baths represent one of the highest points in their building but the buildings themselves developed a style of architecture and a grandeur which is rivaled in very few places today. One of the large railroad terminals in New York City follows directly its style of architecture. Above we see the interior of Carcella's bath. It was forty-nine feet higher than the Statue of Liberty, and one hundred and fifty feet higher than Cleopatra's needle. This was one of the most sumptuous buildings ever constructed by man. Marble from Egypt, of various colors, was used for the entire interior facing of the building, while the arches and ceilings were covered with mosaic pictures; statuary of glass, ivory, bronze and gold was scattered promiscuously throughout. Through the central arch we see the beginning of the cold bath, and to the right through the sectional arch one of the warm baths for women. There was also a library, lecture room, theatre and gymnasium.



# Baths and Water Systems

BEECHER BUNNELL

Since there were more than six hundred Roman baths, such as those described on the opposite page, millions of gallons of water were necessary to keep them in operation. Much of this water was carried over the city in aqueducts, one of which is shown below. The section shown in the illustration below stands near Nemausus still in almost perfect repair. It is one hundred and sixty-eight feet high. There was also a passage on the lower level for men and vehicles. The whole arcade was built of stone and brick and supported entirely by the arch work. This is only one of a dozen or so aqueducts which helped carry Rome's great supply of water. A gravity system transported the water in practically all cases. The valve system for protection used in these aqueducts, is shown in the sketch to the right. There was a strip thirty feet wide on either side of the aqueduct, where no trespassers were allowed.

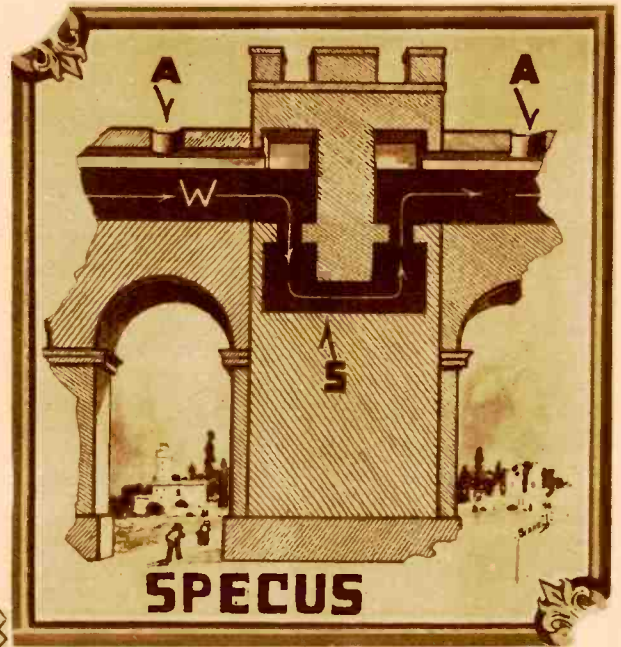



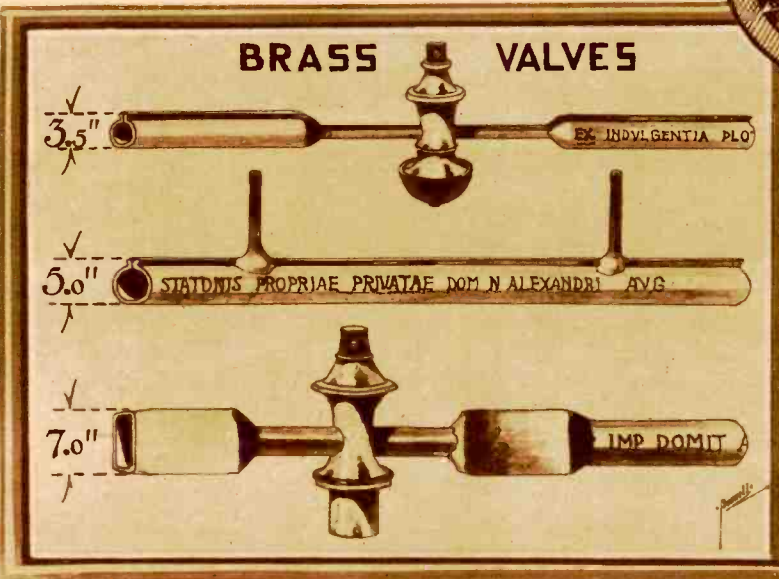
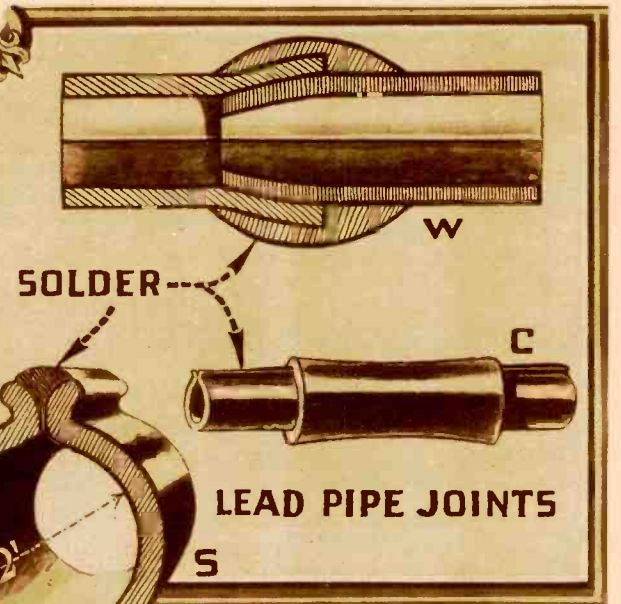
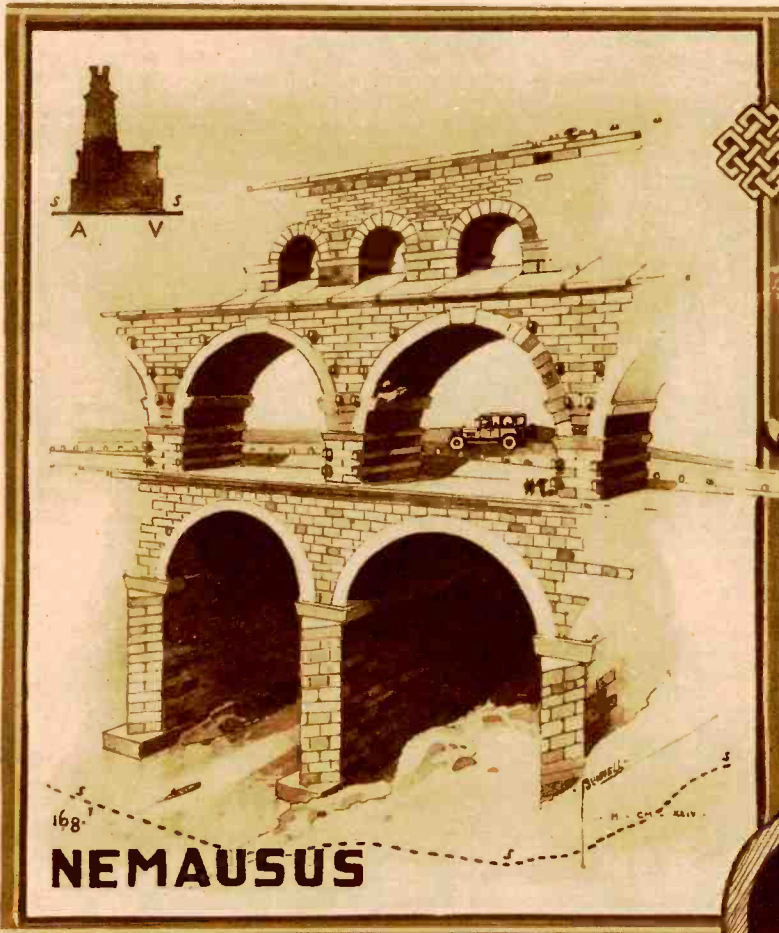





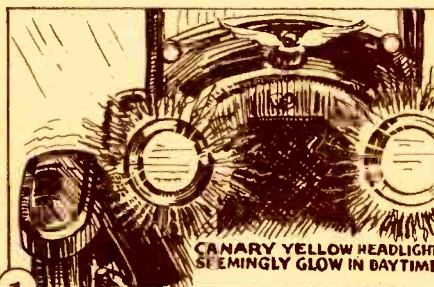

Above is a longitudinal section of a typical aqueduct entering the city of Rome itself. This valve arrangement was duplicated about every half mile in the line. It consisted of a tower where the water was forced to flow through two narrow openings, as shown. At A are two vents which were duplicated at every such tower, which released air compression pressure within the piping. These walls and apertures were used primarily to check the momentum of the water, since the fall was about six inches in a hundred feet. The arrows indicate the flow of the stream through these traps.

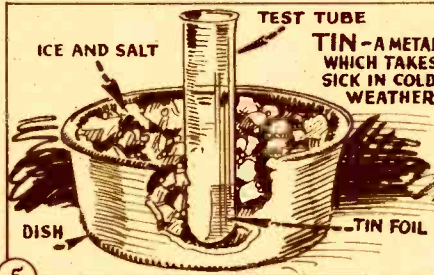

At the left are shown several sections of Roman pipe with brass valves. These valves are identical in design with those which we use today, the only difference between the two being the outside form. Most of the pipe used for interior purposes was made of lead in the form shown in the inset immediately above. Long sheets of the metal were laid out, then placed around a wooden stick, and the ends soldered. At W is given a cross-section of a joint made between two metal pipes, showing how the hot solder was "wiped" around the outside. On cast metal pipe many names and inscriptions were placed. Usually the name of the house owner was found upon the pipe, since water privileges were granted only for a lifetime. Each consecutive heir had to obtain permission for himself to use the water and pipes upon the decease of the previous master. Joints and seams were made in different ways: Poured in strictures, made with a soldering iron as at C, or "wiped" as at W. The latter method is still used.

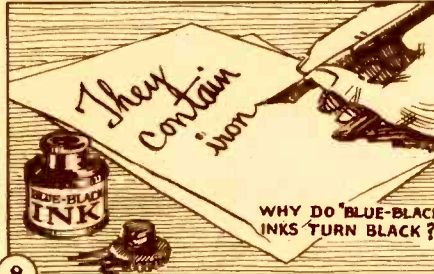
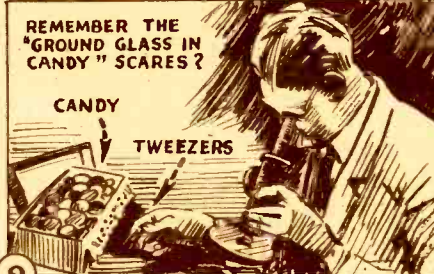
# Everyday Chemistry

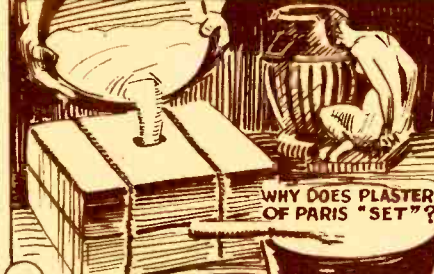
By RAYMOND B. WAILES

 <p><b>1</b> CANARY YELLOW HEADLIGHTS SEEMINGLY GLOW IN DAYTIME</p>	 <p><b>2</b> 'BUGS' ARE NOW MADE TO LAUNDER SOILED CLOTHING</p>	 <p><b>3</b> IS THIS SIMPLY BOILED TO MAKE THIS ?</p>
<p>The canary yellow glass of some automobile headlights contains uranium. A uranium mineral, pitchblende, is one of the parent ores from which radium is extracted. The peculiar daylight color is due to the fluorescence of this glass caused by the higher frequency rays of the sun acting upon it.</p>	<p>Bacteria are being used to launder clothes, such as stiff collars and cuffs. By fermenting the starch in the article, the starch is converted into a liquid instead of a solid, so the dirt simply falls away, leaving the article clean. The dirt originally was attached to the starch, not the fibre of the cloth.</p>	<p>Boiled linseed oil is not simply the raw product subjected to heat. Compounds of lead and manganese are added to the oil before the boiling is effected. Oil treated in this manner, when mixed with lead or zinc for making paint, dries and leaves a better coating than the raw product.</p>
 <p><b>4</b> TEST FOR BORAX IN HAIR WASHES, WITH ALCOHOL AND STORAGE-BATTERY ACID</p>	 <p><b>5</b> TEST TUBE ICE AND SALT TIN - A METAL WHICH TAKES SICK IN COLD WEATHER DISH TIN FOIL</p>	 <p><b>6</b> WHY IS THE GLASS IN SODA POP BOTTLES GREEN ?</p>
<p>Many hair washes now sold contain some borax. A simple test for borax is made by mixing some of the wash in a dish, adding alcohol to it, and then several drops of acid from a storage battery. If a flame green on the edges appears from the mixture when lighted, borax is present.</p>	<p>Tin is greatly affected by cold. If a thin piece of tin (not lead) foil is placed in a test tube which is dipped into a mixture of salt and ice, the foil will assume a grey hue and become exceedingly brittle, so that the slightest vibration will cause it to crumble into dust.</p>	<p>Different metals produce different colors when their salts are added to glass. Soda pop bottles are usually made of a cheap grade of glass containing impurities. Iron is the most prominent usually found in glass sand, hence the green color of the soda pop bottles. Pure sand gives a pure white glass.</p>
 <p><b>7</b> MAKING SYNTHETIC RADIO 'CRYSTALS'</p>	 <p><b>8</b> WHY DO 'BLUE-BLACK' INKS TURN BLACK ?</p>	 <p><b>9</b> REMEMBER THE 'GROUND GLASS IN CANDY' SCARES ? CANDY TWEEZERS</p>
<p>Many of the synthetic radio crystals on the market are made at cost of approximately five cents each. Lead shavings are simply melted in a pot, and then flowers of sulphur are added. When the solution stops burning, the whole is poured out and lo! we have half-dollar radio crystals, sold at the radio stores.</p>	<p>The blue-black inks first write blue but with age turn black because the iron in them takes up oxygen, forming a compound which gives a deep black color. The original blue was, in reality, simply a dye added to the mixture, which held the iron in solution and kept it from turning black before aging.</p>	<p>Most of the "ground glass" candy which was so widely talked about during the war contained no ground glass at all but little hard crystals of a compound of the acid taken from grapes and other like substances, which closely resembled Rochelle Salts but were not dangerous.</p>
 <p><b>10</b> YOUR STOVE FIRE HELPS THE FORMATION OF CAVES</p>	 <p><b>11</b> WHY DOES PLASTER OF PARIS 'SET' ?</p>	 <p><b>12</b> WHY IS THE PRETTY PURPLE 'PERMANGANATE' USED FOR INFECTIONS ? PERMANGANATE OF POTASH</p>
<p>Every fire and breath of air we breathe is working to make more caverns in the earth. Both processes evolve carbon dioxide which is absorbed by water, which in turn seeps into the earth. This aerated water is carbonic acid and eats away, slowly, to be sure, the limestone in the earth.</p>	<p>Plaster of Paris is calcium sulphate deprived of its water, which causes it to powder. When water is again added, it assumes its original hard rock-like form, which is the usual state in which we see it, as it stands molded into statues about our homes. This change in form is due to crystallization.</p>	<p>The pretty purple permanganate of potash usually found in first aid kits is of value only because it holds oxygen with it. When it is poured on a wound, the oxygen is active, attacking infections or impurities in the wound, thus effecting a cure. The potash solution itself is of no aid in healing.</p>

## Game Incorporates DX Thrill

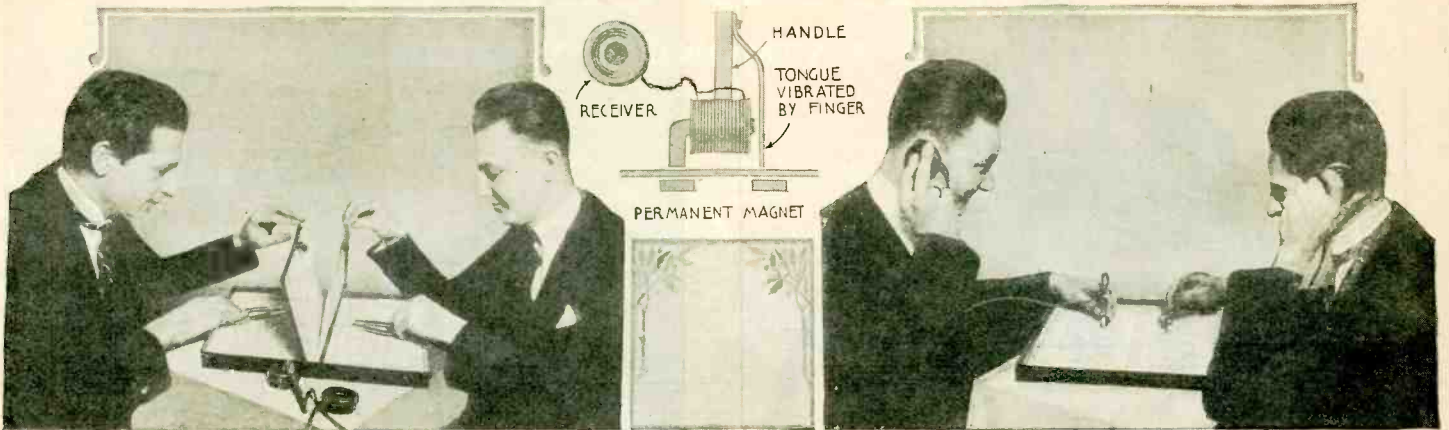

Now that every village and town has its new crop of "Distance Hounds," and that summer is on us at the same time, playing havoc with the ability of said hounds to perform their near miracles, the game illustrated above will help tide them over the hot season, until they may again tell each other distance records with the return of more clement radio weather. It is simple in the extreme, this game, and interesting. There are two

maps of the United States on which are marked the location of broadcasting stations. Each player places a permanent magnet under the location of a station and drops the map over it. Then the other player takes his "receiving set" (shown at the insert sketch) working the vibrator and moving about over the map. When over the magnet a buzz is heard in the receiver.

## Stopping Phonograph Stops Motor

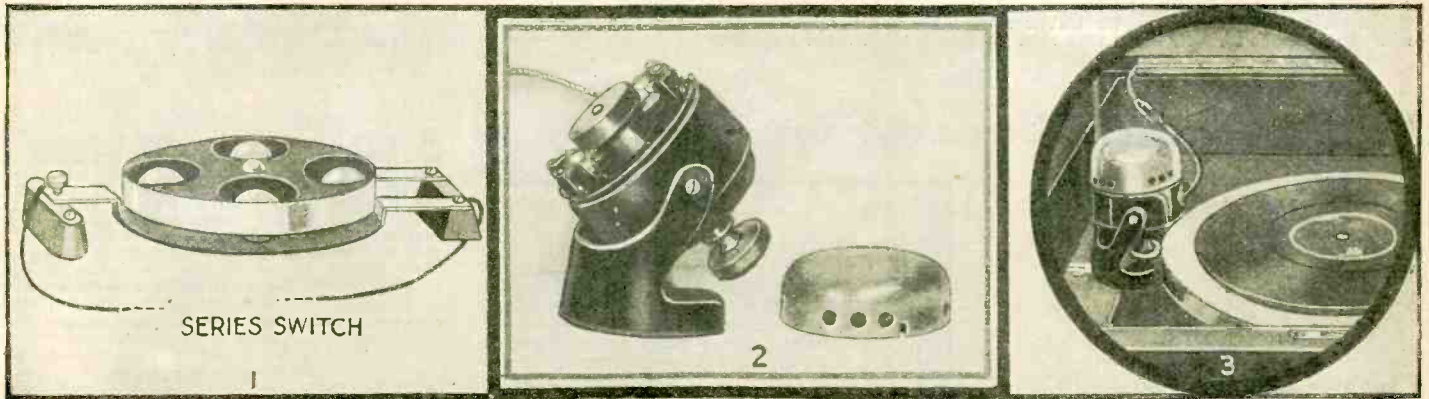

Possibly the simplest and most efficient phonograph motor control which has been designed to date is the one shown in the above photographs. It is a regulation fractional horsepower motor equipped with a stand, so it may be placed upon any phonograph without alterations of any kind. The novel feature, however is the series switch which controls the motor. By simply giving the turn-table of the phonograph a twirl the motor starts while

it is stopped by simply retarding the table and bringing it to a stop. Details of the switch are shown at 1. Centrifugal force throws the steel balls outward when the motor is running, lifting them from their supports which bear on two side arms which make and break contact. If the disk is stopped the motor is slowed down and the balls fall back opening the contacts.

## New Jazz Instrument

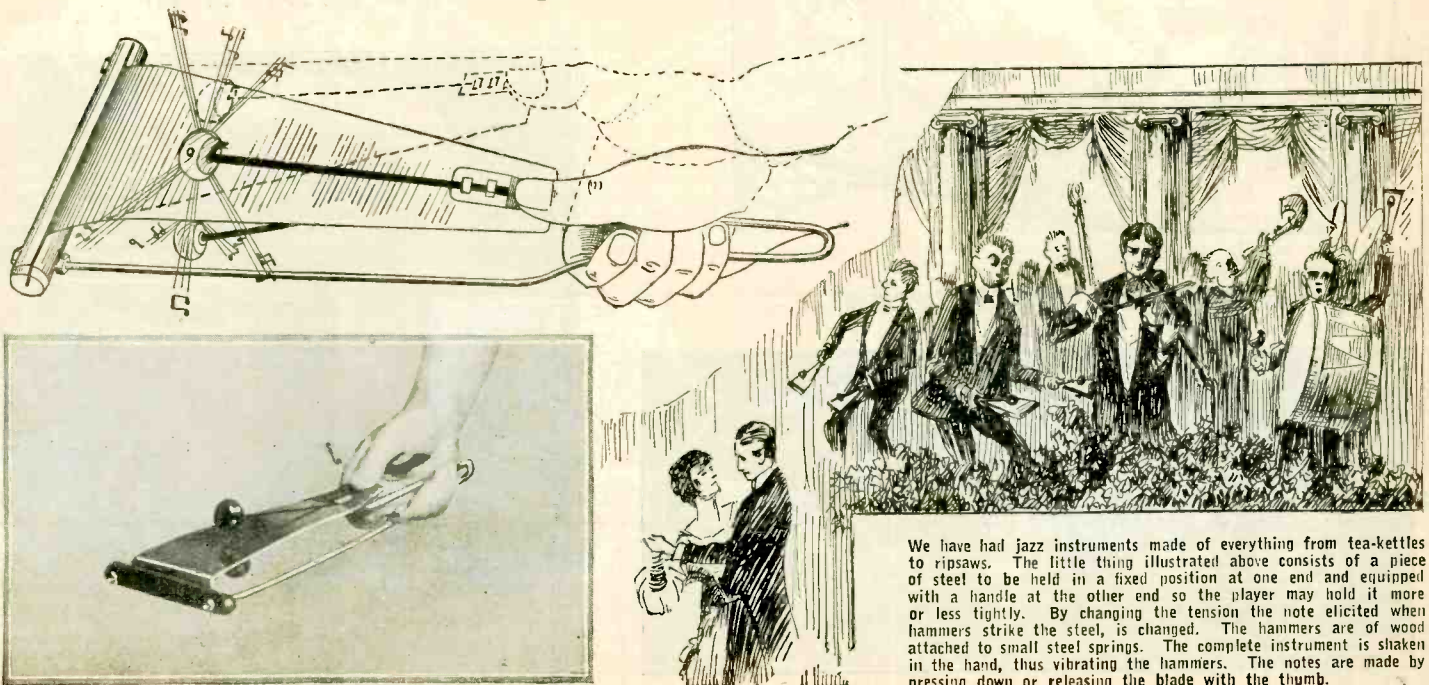

We have had jazz instruments made of everything from tea-kettles to ripsaws. The little thing illustrated above consists of a piece of steel to be held in a fixed position at one end and equipped with a handle at the other end so the player may hold it more or less tightly. By changing the tension the note elicited when hammers strike the steel, is changed. The hammers are of wood attached to small steel springs. The complete instrument is shaken in the hand, thus vibrating the hammers. The notes are made by pressing down or releasing the blade with the thumb.

—Alexander Kofae.

## Ice Experiment

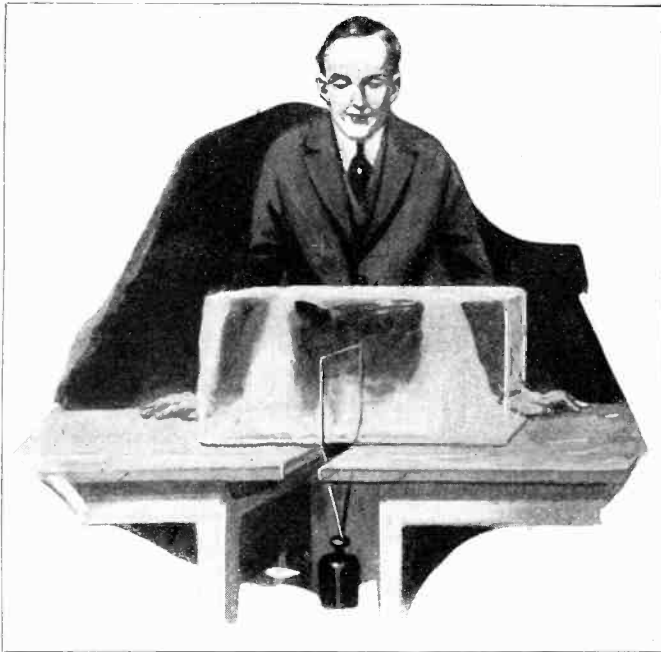

Place a weighted wire on a cake of ice as shown above and then bet your friends that it will not cut the cake in two. The trick is simple. The wire cuts but with the relief of the pressure the water freezes again above the wire. —Dr. Albert Neuberger.

## Smokers' Paradise



The U. S. Department of Interior has just completed the experiment shown above, viz., placing smokers in a closed room and letting them smoke away for eight hours. It was to determine the injuriousness of carbon monoxide from burning tobacco. It was found not to be dangerous in the least.

## Handy Locator for Map



At the left is seen a new idea applied to locating points on a map. The name of the locality and the two key numbers are printed on the reverse side. When finding the spot on the map it is only necessary to ascertain the two key numbers, turn the map up as shown so that the edge of the face of the map intersects the number on the edge of the face of the map corresponding to the one given and then run across the top of the reverse side where another set of numbers are located until the second of the key numbers is located and—there you are. —Mr. Pleasant.

## Aquarium

Below is shown a double aquarium, or rather a method of connecting two aquariums so that the fish in them may move freely from one of the bowls to the other. A large glass tube in the form shown is filled with water and is quickly inserted into the two bowls. The equality of the atmospheric pressure on the two bowls will not allow the water to flow out of the tube. In selecting a tube, be sure that the one used is large enough to permit the fish to pass through it. After filling it with water, place the palms of the hands or sheets of glass over both ends so that the tube is full of water when the ends are placed in the bowls.

—J. W. Paetznick.

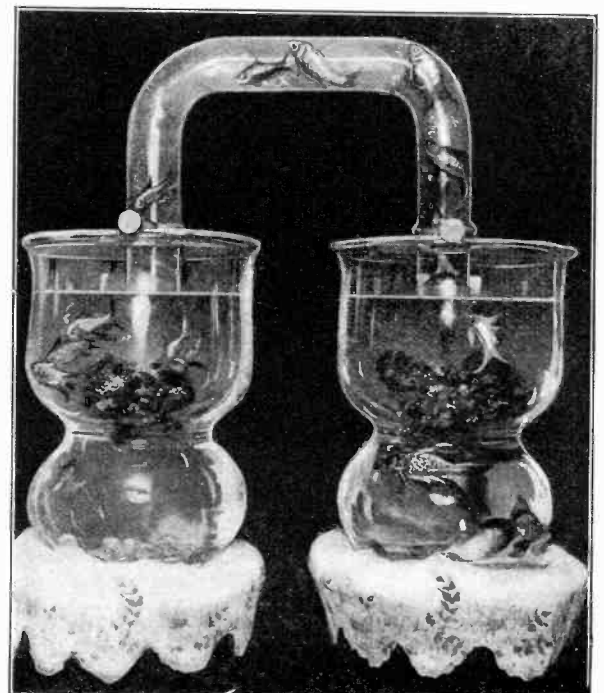

## Small Cacti Craze

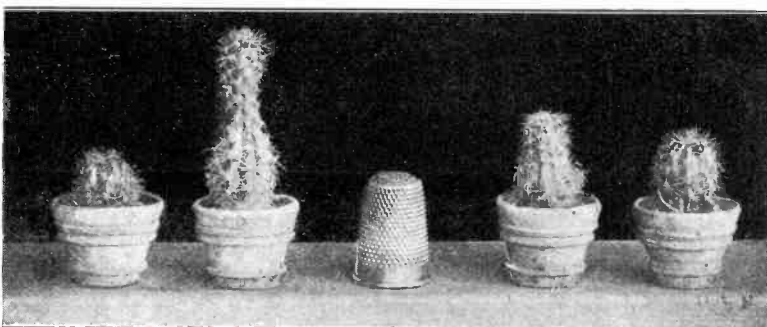

One of the latest English fads is the collection of miniature cacti. The prevailing pots in which these plants are set are thimbles. Some samples of the plants are seen in the above illustration. —S. Leonard Bastin.

# Electricity--Destroyer of Airships

By C. A. OLDROYD, AERONAUTICAL ENGINEER

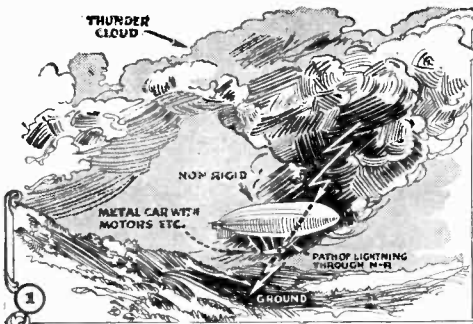
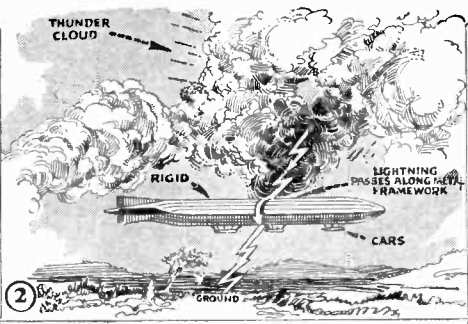

Fig. 1 shows lightning striking a non-rigid airship. It is likely to be ignited as all metal parts are massed together in the car below the gas bag, as lightning follows the easiest path, it naturally strikes the car.



With a rigid airship, Fig. 2 (Shenandoah type), whose framework is entirely metallic, there is a chance that although it may be struck by lightning, the ship may escape destruction by fire.

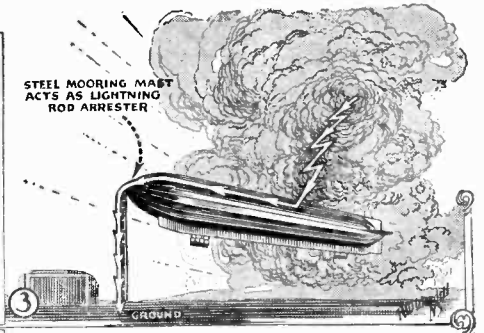
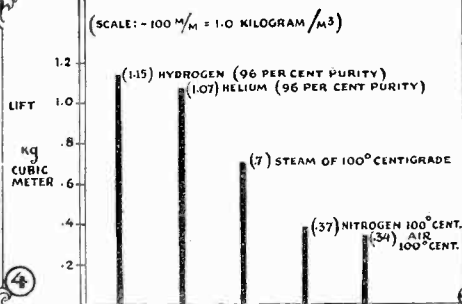

Fig. 3 above shows lightning striking a rigid type airship, the chances being that the discharge will pass along the metal frame-work of the airship and thence proceed to earth through the metal tower or mooring mast. The Shenandoah uses such a mast.



The airship designer is always looking for an extra light and inert gas. Aside from helium there are several gases that might be employed. The black lines above show clearly the relative lifting powers of various well known gases, including steam and hot air.

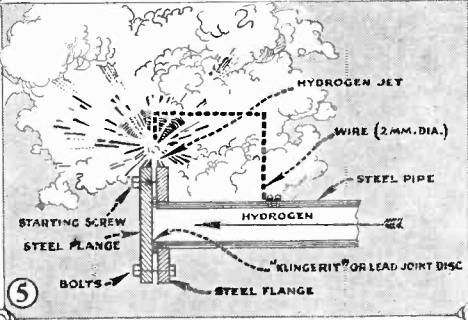

Fig. 5 above shows device used by Professor Nusselt, in demonstrating that static electricity ignited hydrogen gas leaking through a joint. If the pointed wire shown was not used and a little hydrogen allowed to leak out, the electricity present due to friction of the gas in the pipe caused the latter to ignite.

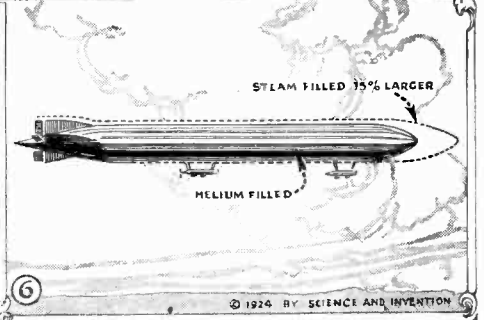
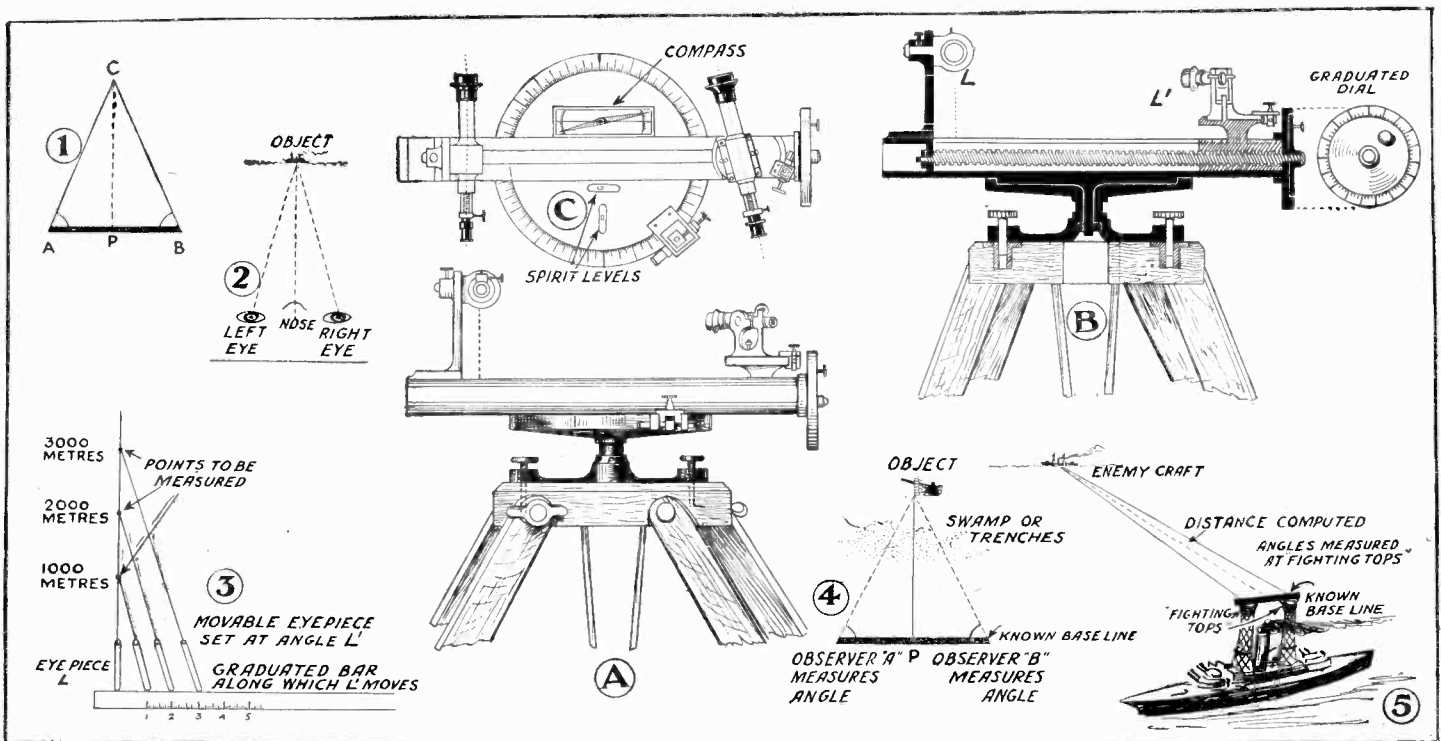

Fig. 6 shows clearly how much larger a dirigible would have to be in order to have the same lifting power when filled with steam as compared to helium. In other words, to lift the same load as a helium filled ship, a steam filled ship must be 15% longer.

# The Telemeter--A New Range Finder



The well known method by which our two eyes measure the range of a distant object is shown in Fig. 1, the eyes automatically measuring the distance CP by solving the right angle triangles A and B. Fig. 2 shows the same idea in picture form. Figs. 3, A, B, and C show how the new French range finder known as the "Telemeter" very accurately measures the range whether it be one yard or sixty miles. It is said to have an accuracy of within one meter at a range of sixty miles. It is the invention of M. Faget de Paris and the device is composed of two eye-pieces or tele-

scopes mounted on a graduated metal bar which is fixed to a rotating circular plate. The principle of the device is shown best in Fig. 3. The one eye-piece L is sighted directly on the object, while the second eye-piece L' at the right is moved until it is also trained on the object. The range can then be read off directly along a graduated scale. Diagram 4 shows how two observers, A and B, situated at ends of a known length base-line find the distance of target by measuring the angles at A and B. Fig. 5 shows ship range finder.—Ernest Brennecke.

# Odd Uses for Tractors

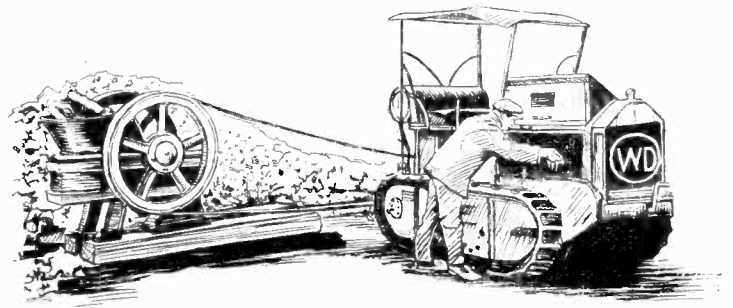
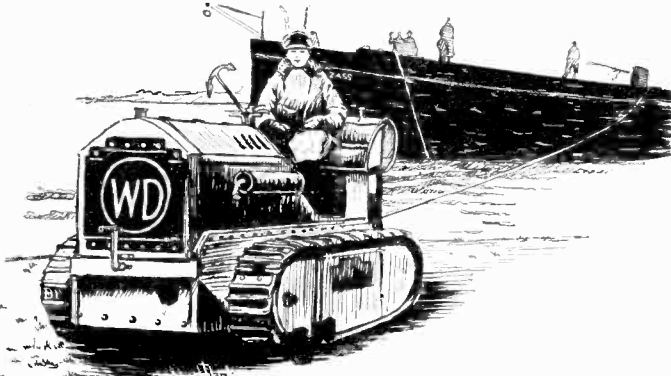

In Holland and in Germany many caterpillar tractors are being put to many odd uses as the accompanying illustrations indicate. The picture directly above shows a tractor being used to haul a canal boat. They are also being used to warp vessels into their piers. The picture below shows a string of wagons, carrying wood, being hauled by one of these versatile tractors. The odd sight of a tractor hauling a long line of wagons is uncommon in this country, but one frequently sees this in travelogue movies of foreign scenes. The tractor can haul a greater load than several horses and is so flexible that it can crawl over the roughest kind of ground, the worst hardship being on the engineer driving the tractor who gets pretty well shaken up now and then.

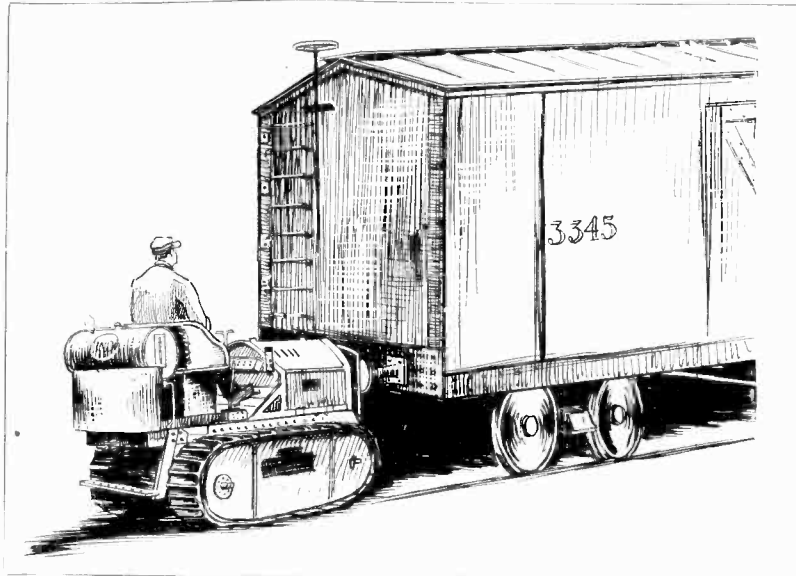

The picture above shows another use for the tractor—crushing bricks. The engine of the tractor is sometimes used for running wood-saws also. The picture at the immediate left shows one use of tractors which is being applied in many foreign countries, that of shunting freight cars on and off of sidings. A special form of tractor for this particular purpose was shown in a recent number of SCIENCE AND INVENTION. Below is shown a stump puller attachment fitted to a farm tractor. One can well imagine what a time-saving combination this makes when compared to the old-fashioned method of pulling stumps by means of a horse-driven windlass. With this machine on the scene the stumps can be pulled and then carted away on trailer trucks. Europeans are showing us many novel tricks with tractors, and while there are, without a doubt, more tractors in use in this country, thanks to Mr. Ford, we can learn many valuable methods by keeping our eyes on the foreign journals which cover this sort of work. Among the interesting new developments in Europe is an engine fuel to take the place of gasoline.

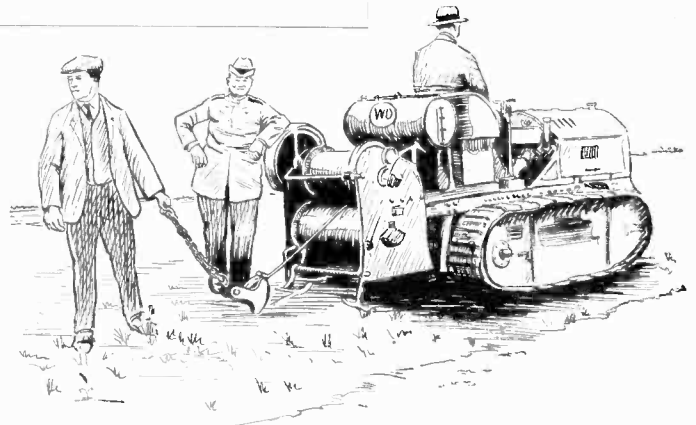
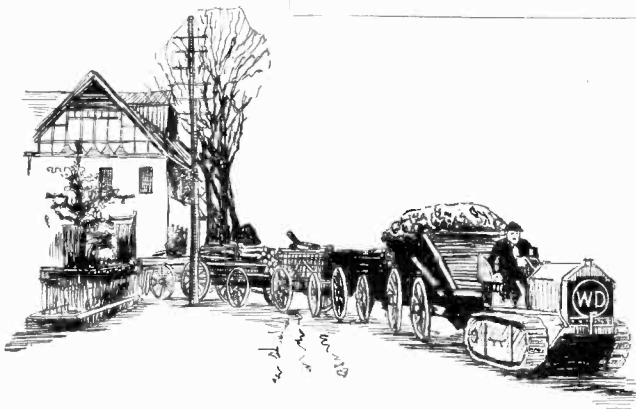

## New Auto Shock Absorber

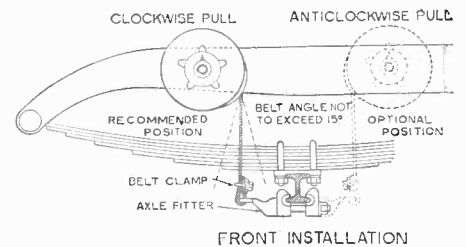
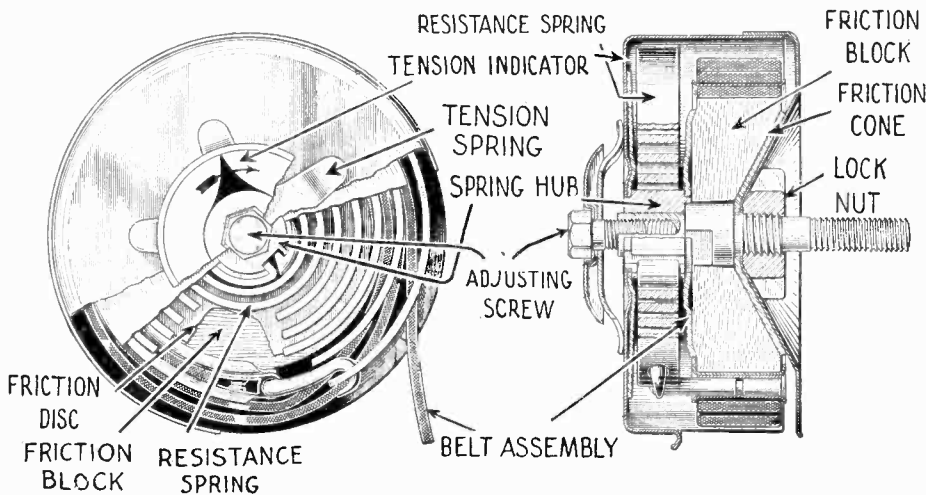

The drawings above and at the left show one of the latest auto shock absorbers. It utilizes a combination of friction and coil spring action. The main parts of this shock absorber are a conical-shaped friction drum of the oil-less bearing type, a large coil spring of the clock type, and a belt for connecting the mechanism of the shock absorber to the car axle. The picture above shows how the shock absorber may be attached to the axle and car frame in two ways. There are no metal bearings in this device, the makers claim. The coiled spring keeps the belt taut at all times, while the tension as well as the degree of friction is adjustable. This shock absorber is furnished in small, medium and heavy car sizes.

### Fly Screen

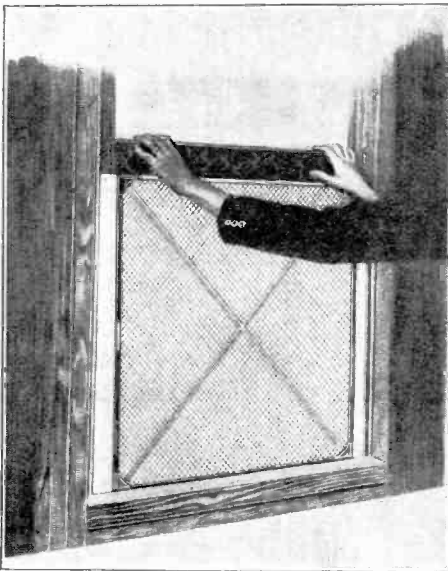
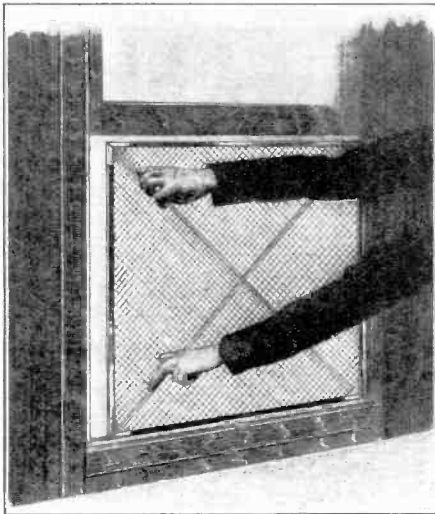

In the crown of the hat shown above a small circle of absorbent paper is fixed with adhesive. This paper has been previously soaked in a solution of one part of cobalt chloride, ten parts of gelatin and 100 parts of water. If the paper turns pink it indicates moisture in the atmosphere or in the hat.

—S. Leonard Bastin.

This fly screen has no slides, yet is adjustable to all windows. It is so constructed that one has merely to fit it in the opening of a window and press the sash down upon it, whereupon it extends laterally until it engages the side walls of the window frame. The edges are telescoping and diagonal braces cross the center. Although the wire is woven the individual strands are not soldered. These strands are free to change their angles with reference to those crossing them. —J. W. Von Stein.

### Fair Weather Indicator

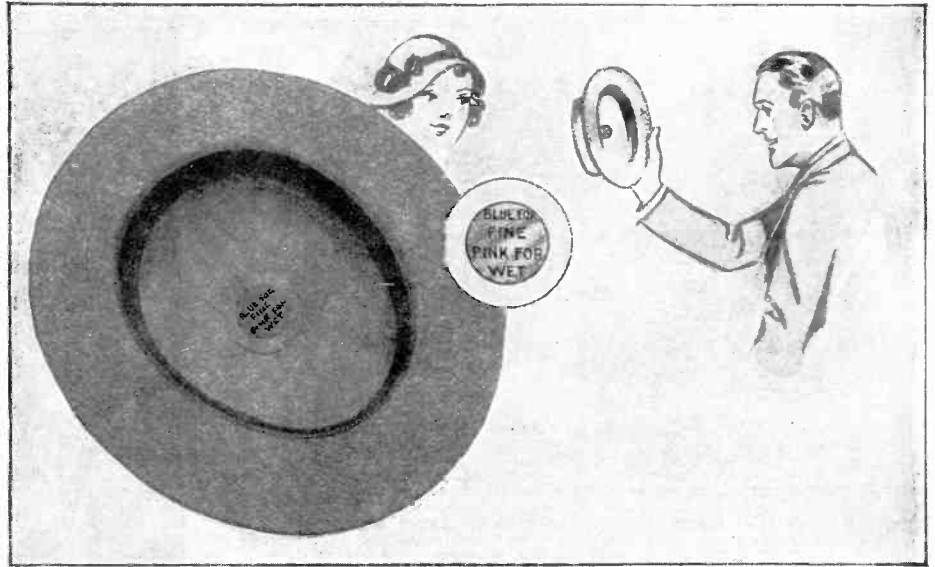

### Detective Camera



Newspaper photographers often have difficulty in securing photographs because the subjects refuse to pose for the picture. Monroe Stroecker, a staff photographer of the Detroit News, has overcome the difficulty by placing his camera in an over-night bag. A hole is cut out for the lens, and at the same time that the shutter is released, the flashlight powder is automatically ignited. —Chet Shafer.

### Nature Heats Houses

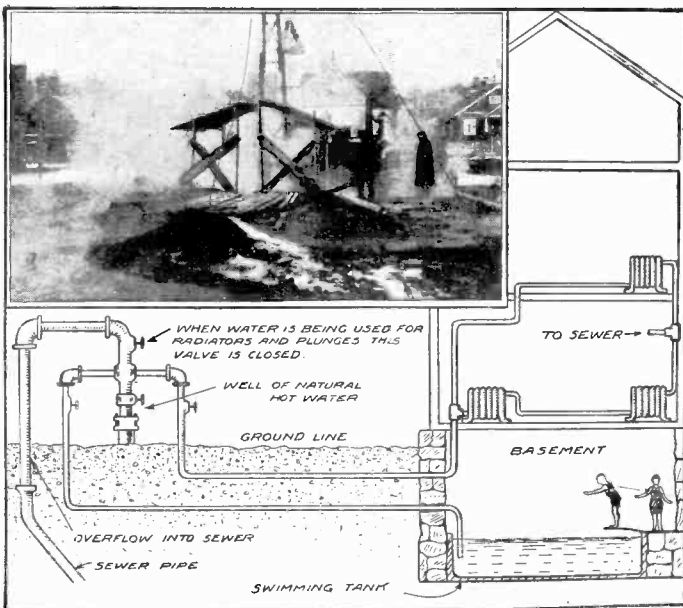

At Pagosa Springs, Colo., artesian wells are driven to a depth of 380 ft., where a supply of hot water is obtained. This is run through the buildings in the manner shown in the diagram above, and continuously heats the buildings at practically no cost. Photo shows an artesian well just before it was capped and put into use. —L. Pinn, Reporter No. 4129.

### Pneumatic Wheel

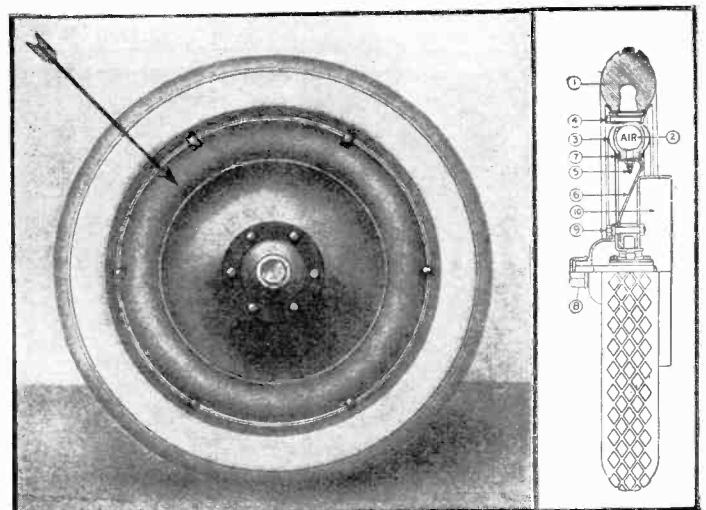

Arrow points to the pneumatic air cushion indicated in the drawing at 2. The tire is solid and is shown at 1. At 3 we find a protecting plate covering the air cushion which slides up and down on point 7. The air valve stem is shown at 5, while 6 is the steel disk holding the tire to hub 8 by bolts 9. —J. W. Von Stein.

## "Telegraph" Plant

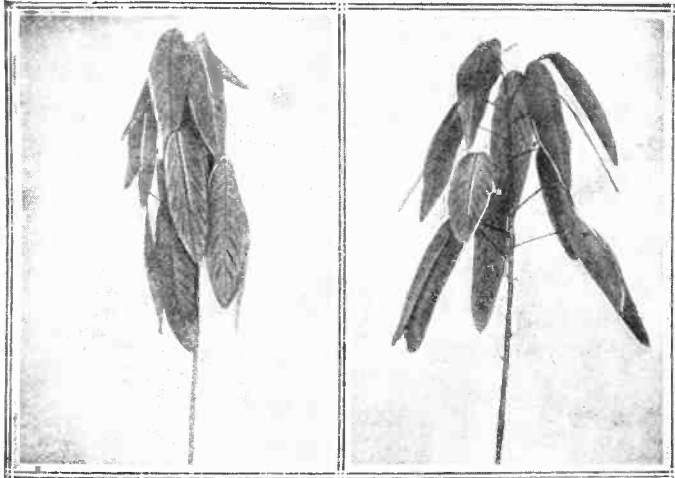

The plant shown in the above illustrations resembles a telegraph instrument in that the two small leaflets that grow on each side of the large central leaf are continually jumping and jerking. At night the plant "sleeps" by folding its leaves as shown in the photo to the left. Also, at the approach of a storm the plant follows the same course making it a good weather prophet. —S. L. Bastin.

## Intelligence of Eel

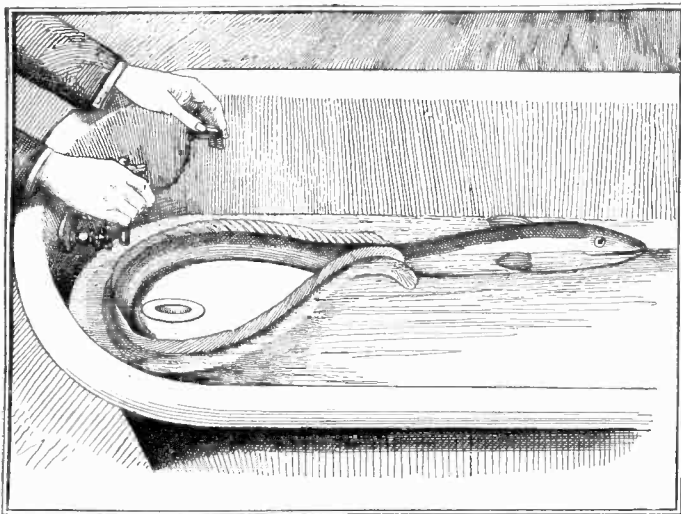

Kosmos, a German scientific journal, quotes an observation made by one of their readers which would seem to point to a more than usual degree of intelligence found in an eel. When the stopper of the bath tub in which he was living was removed he took care to preserve his life by using his tail as a dam as shown.

## Easily Performed Coin Trick

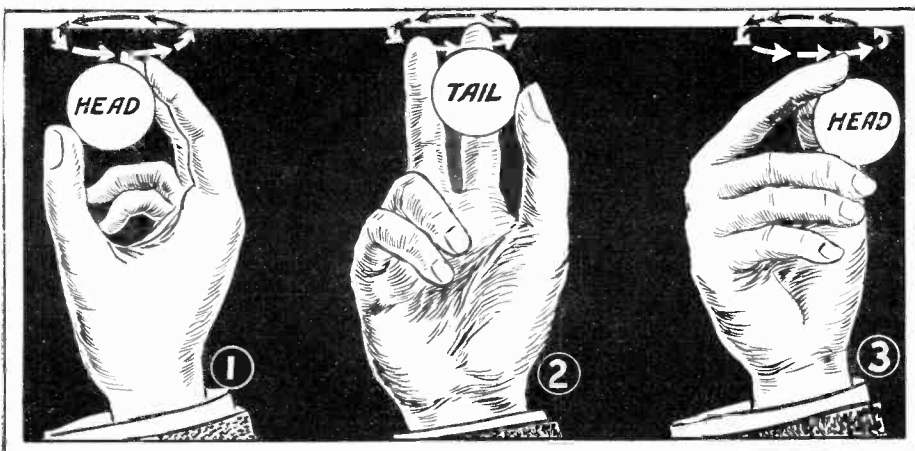

By the easily mastered manipulation illustrated in the above sketch one can convince on-lookers that a coin has a head on both sides. The coin is held between the thumb and forefinger and the hand is given a half turn. But

while the hand is making the turn the coin is also given a half turn in the hand by shifting it from between the thumb and forefinger to a position between the first and second fingers. —Franklyn Kenchion.

## Phonograph Novelty



The inventor of this device, Robert A. Rummel, makes it possible to see the singer at the same time her record is heard on the phonograph. The device consists of a reflecting projector placed in the base of the musical instrument.

## Watson! The Needle

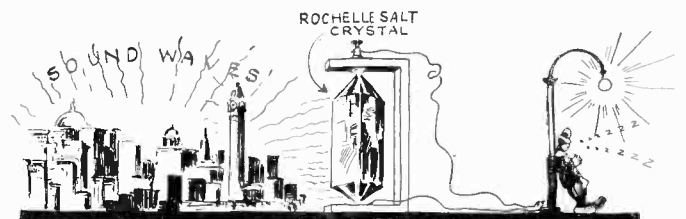

Above is shown the bright idea of a Western inventor. He would supply the electric power needed by cities by putting their noise to work. As illustrated the noise impinging on a Rochelle Salt crystal would set up piezo-electricity.

## Shoe Preserver



Castor oil is good for many things aside from its medical and electrical value. Above is shown another use. If a coat of it is applied to the soles of shoes it will not only leave the leather much more pliable but it will also increase its wearing qualities. —Ernst. Keil.



# Magic for Everybody

By Prof. JOSEPH DUNNINGER

NO. 18 OF A SERIES

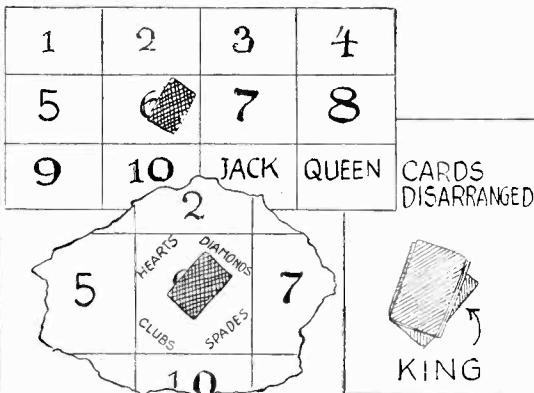

The magician requests that his assistant be blindfolded and leave the room. He now asks one of the audience to select a card from a pack, look at it and return it to the same. The cards are placed face downward on the table. The assistant returning,

instantly names the card mentally selected. The magician placing the cards face downward on the table indicates the suit and value by their position on the table. The table is mentally divided up into sections as indicated. Disarranged cards mean a King.

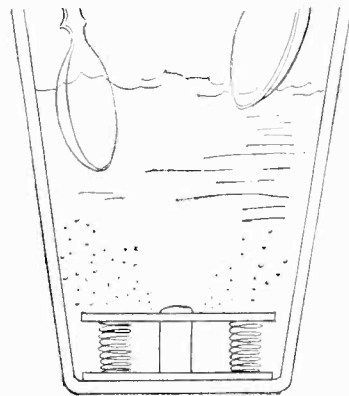
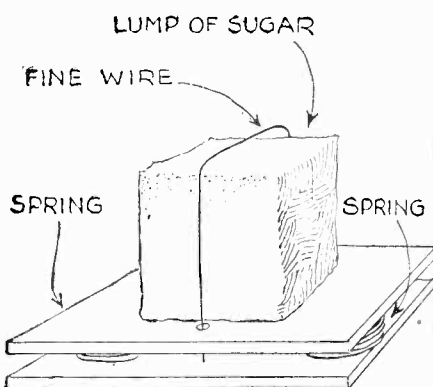

The magician puts two spoons into a glass, fills it with water and at his command the spoons fly upward into the air. The spring system used is illustrated above. A lump

of sugar prevents it from acting until the sugar melts. The contents of the glass including the spring are then poured into the pitcher and the glass passed for examination.

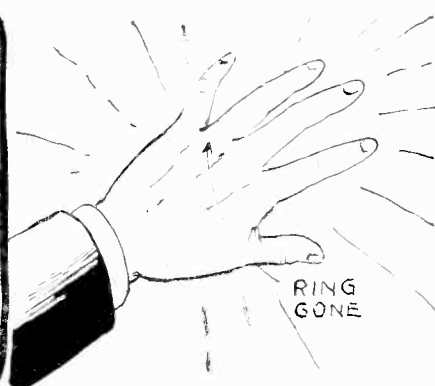

The performer's mystic ring has the property of vanishing at his command. A puff of smoke and presto! The ring is gone. The ring is really a half ring. A rubber band is

attached to one end and a flip of the thumb releases it from the finger. The ring slips into the performer's coat sleeve under cover of the cloud of smoke.

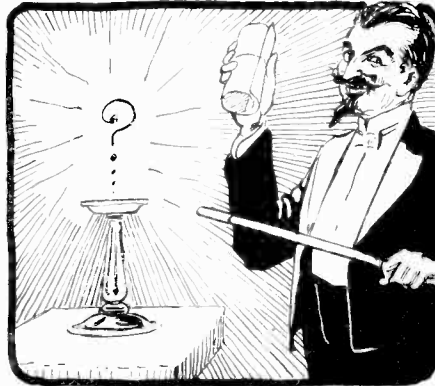
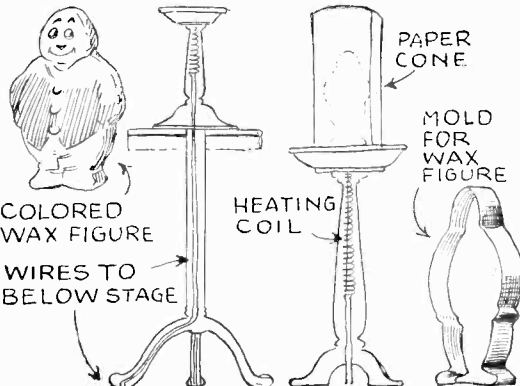
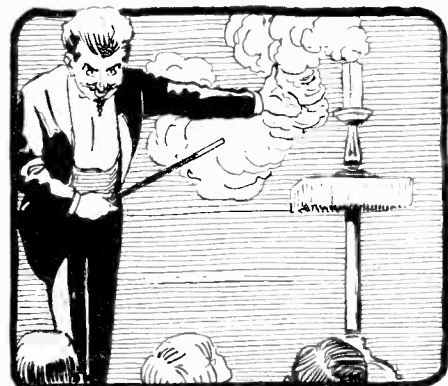

The figure shown above is solid and is passed around for examination. It is put on a stand and covered with a roll of paper. A little smoke indicates that the figure has

vanished. Sh—the figure is wax and the heating coil in the stand melts it. The wiring is concealed in the candle-stick holder and passes down through a leg of the table.

# More Gamblers' Tricks Exposed

By MARK MELLEN

The Man Who Fooled P. T. Barnum

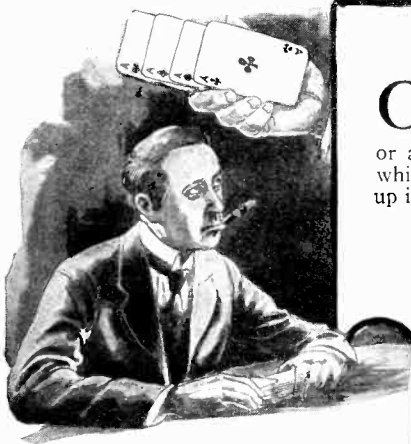

Above, the gentleman has just slipped all the aces from the deck preparatory to dealing himself one fine hand in a poker game. He is able to do it with the use of the shearing apparatus illustrated on this page. The tyro hasn't a chance in a game with slipped cards such as those used in the above illustration.

CARD sharps often use cards that are not uniform in size and shape, which are called sorts, wedges, strippers or high and low cards. They are made by trimming a sliver off the edge or at the end of the cards. For the game of banker and broker, which is simply cutting for the high card, every card from seven up is trimmed so that the edge is slightly concave. As the uninitiated player always picks his cards up from the center of the long side, he of course always cuts the low card and thus loses. The same plan is followed for other games. In poker the card's edges are trimmed so that the ace is cut. Strippers are cards trimmed in such a manner that certain ones of the deck can be stripped or pulled out without the act being detected. In this case, all the cards except those desired, say the aces, are trimmed by taking off a slight sliver of uniform width the full length of the card. The aces are then fixed with convex edges as shown, so that by simply grasping the cards in the usual fashion, the dealer, with one stroke, can pull the four aces from the deck. For playing euchre, the jacks are prepared thus, and for casino the two-spot of spades and the ten of diamonds. The cards are sometimes fixed so as to be wedge shaped, for in playing bridge-whist, it is an advantage to control the spades, in which case all spades will be made in the shape of wedges with the other cards slightly reduced. Thus the spades may be slipped from the deck. The illustrations show advertisements from catalogs of various card concerns for card trimming devices. However, decks already prepared in this way may be obtained from many houses already cut, thus saving the sharper the trouble of preparing the cards. Of course trimming the corners and sides is also used as a system for marking cards.



The gentleman above is in the act of shuffling the cards which have been trimmed. He can place high cards in any position in the deck. The gentleman below is trimming the deck.

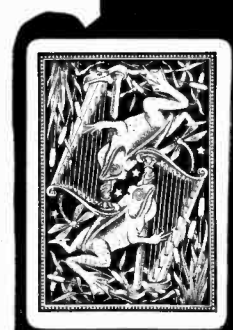

THE PERFECTION CORNER CUTTER  
MADE AND SOLD BY US ONLY

This tool is made for rounding the corners of cards after removing giving the sucker a neat and finished appearance. Made of brass and steel, nothing to get out of order, cuts absolutely accurate and is faster than any tool of this kind ever made, making the corners appear exactly the same as new cards. Weight, 1 1/4 pounds. Each \$22.50

No. 20C208

Each \$22.50

PLAYING CARD TRIMMING SHEARS

If you use many playing cards and want to save one-half of your card bill get a pair of these shears. Anyone can learn to operate them in a short time.

With these shears there is no need of throwing away cards as soon as the edges are soiled; save them until you have several decks and then trim off the soiled edges. This makes them as good as new, and all cards can be trimmed four times or more the saving in cards will pay for the shears in a short time. Also with these shears it is very easy to make your own Strippers, High and Low Cards, Sorts, Weights, etc. An absolute necessity for all Faro Dealers in keeping their cards in shape. Shears are mounted on a square brass block, guaranteed to cut absolutely square and fitted with a special attachment for cutting lines. Weight, 6 pounds. No. 20C235

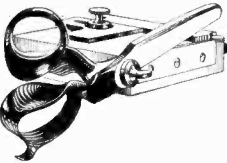

Extra Special Shears with Micrometer Attachment

With this attachment you are enabled to cut a piece from the card as thin as tissue paper and so accurately. Nothing like them ever sold before. No. 20C234

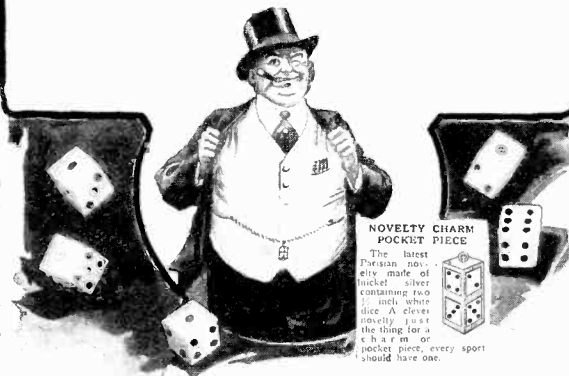

NOVELTY CHARM  
POCKET PIECE

The latest Parisian novelty, made of nickel silver containing two 1/2 inch white dice. A clever novelty, just the thing for a chain or pocket piece, every sportsman should have one.

Most innocent looking is this pair of dice in a silver cage worn as a watch charm. However, they are not so innocent since they are both loaded. A hole is simply drilled beneath one of the spots filled with a heavy metal, and then the spot replaced and colored.

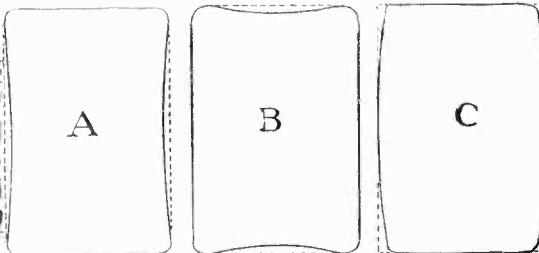

Above at A is shown a card trimmed with the side edges concave. At B the ends are made concave, and at C the edges convex. The dotted line shows the original shape of the card. By these expedients the card sharper when he is dealing, has almost absolute control of the deck. The sucker will do well to hold the cards about twenty inches from his eyes between his face and the light, and see that the deck is straight before playing. However, suckers see very little and what they see means practically nothing to them.

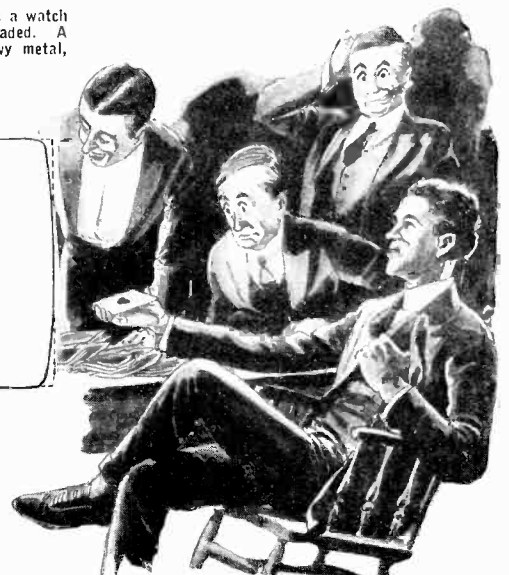

# Scientific Problems and Puzzles

By ERNEST K. CHAPIN, M.A.

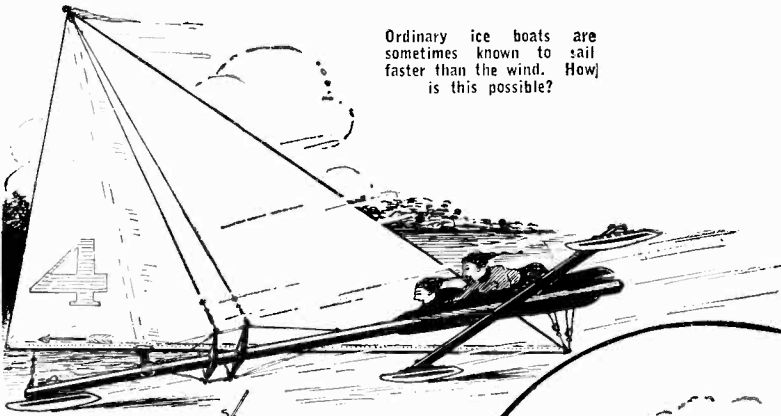

Ordinary ice boats are sometimes known to sail faster than the wind. How is this possible?

How could three bells, six buttons and three dry cells be connected to ring the bells as indicated in the sketch?

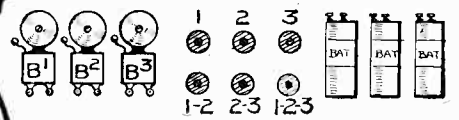
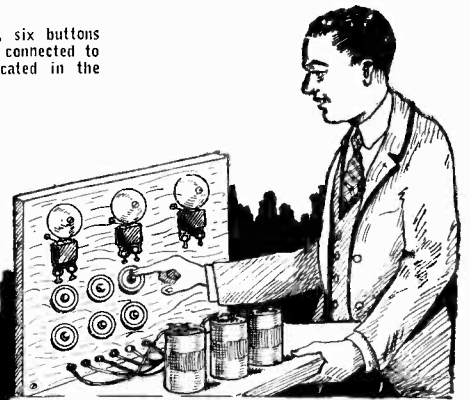

A ball is rotated about its horizontal axis and dropped in water at the same time. Will it sink straight down or be deflected, and in what direction?

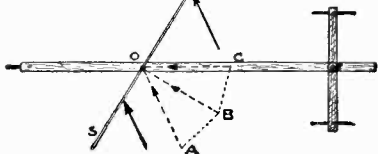

A rift in an ice field has sides which are  $30^\circ$  and  $60^\circ$  respectively. Where must the boy stand on the horizontal board if plank is not to slip, considering the plank's weight negligible?

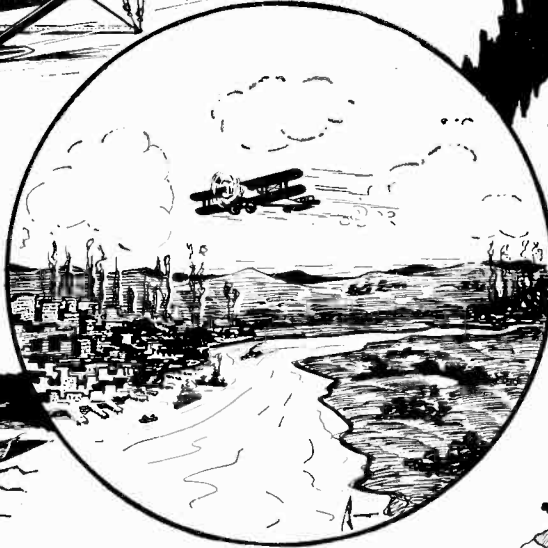

Two flyers making a round trip race fly from city A to B and return. A flies when there is no wind, and B makes his trip when there is a steady breeze blowing in a direct line between the two cities. Which will win?



What's wrong with the idea below? The weight of the water in one side of the casing turns the wheel forever and ever, while the weight of the upper wheel prevents the water from leaking through where the two wheels come together.

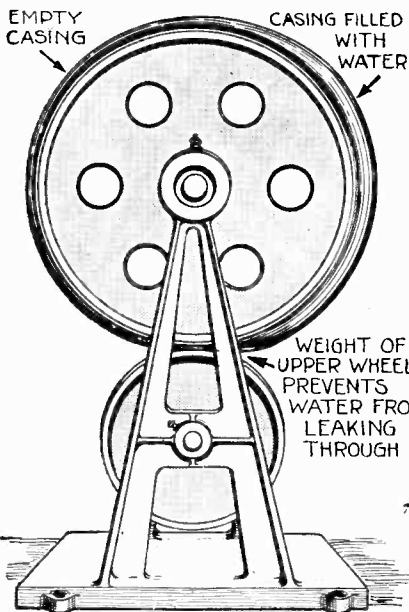

How many incorrectnesses are in the above picture? Considering the balls of equal weight in the sketch below, all of them being started simultaneously, which ball will reach the lower plane with the highest velocity?

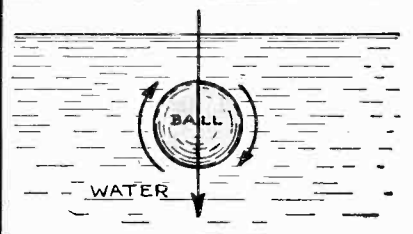

The straight uniform beam square in cross-section floats half submerged in water. What position will it assume?

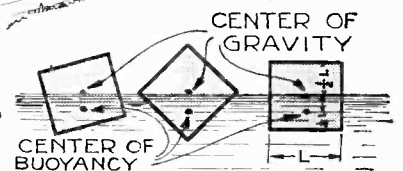
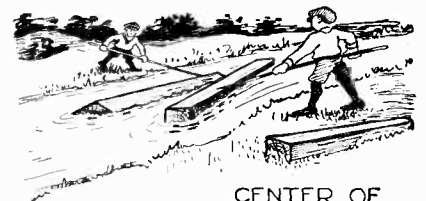
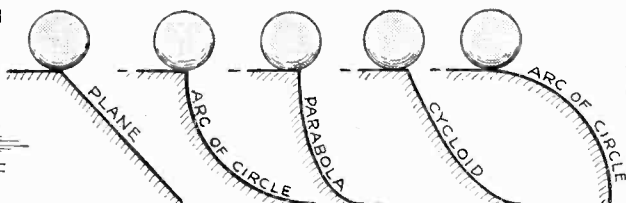

(Answers to these problems given on page 504)

# The Month's New Devices



For summer travel nothing will be found quite as handy as the collapsible perambulator, shown in the two accompanying sketches. For travel it is easily carried, can be opened out at a moment's notice and makes a very pleasant seat for baby for beach or seashore.



The new ratchet jack device shown above is exceptionally useful in hauling heavy loads with very little man power. It may also be used to raise and lower heavy objects with the use of but one man power. The device is the invention of Mr. E. W. Brantigan.

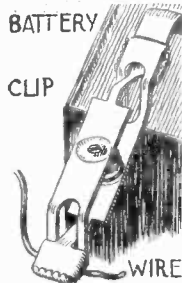

BATTERY CLIP



One of the most handy clips for use in connection with radio battery circuits, that has come to our attention recently, is the one shown in the above sketch. The feature is the double spring clip contact. —E. Pons.



For stenographers who take a great deal of legal dictation or other such work, this knee shifter will be found exceptionally handy and a great ease to the hands. This attachment may be applied to any ordinary typewriter and greatly facilitates the stenographer's work. —Lester Sargent.

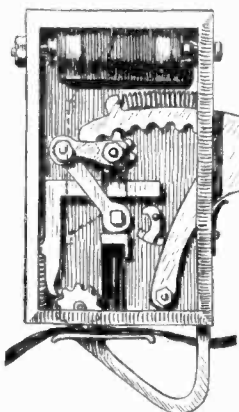
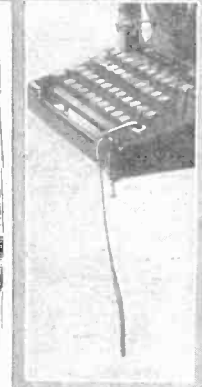

The power being furnished by a trigger, this pocket sewing machine makes a perfect lock stitch seam.—H. W. Garland.

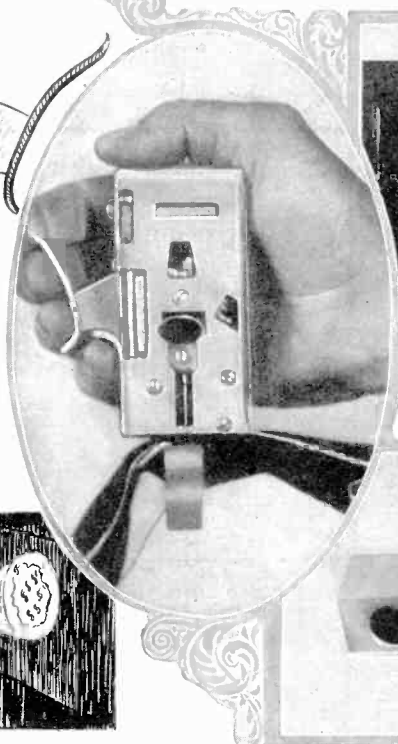

Instead of using the regular victrola for demonstrating records, this new device wherein the auditor uses a telephone receiver-like device, consumes much less space than the old style booths and requires much less attention than the regular instrument.

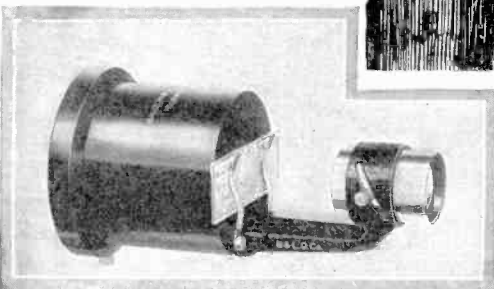
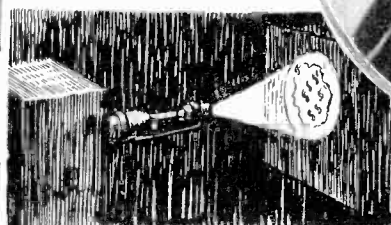

For class study of biological or other studies wherein microscopic slides must be used, it is seldom possible for every member of the class to obtain and use an individual microscope, so the Bausch and Lomb Optical Company have brought out the projection microscope shown in the illustration to the left, which may be attached to the lens of a stereopticon, enabling the image on the microscopic slide to be projected on a screen for the use of an entire class.

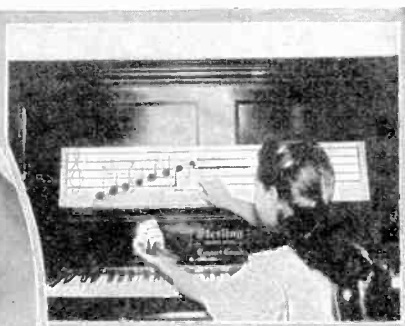

Mr. E. W. Cornell has applied the idea on an abacus for teaching little tots music. The notes and signatures are hung on fine wires representing the lines of the musical staff.

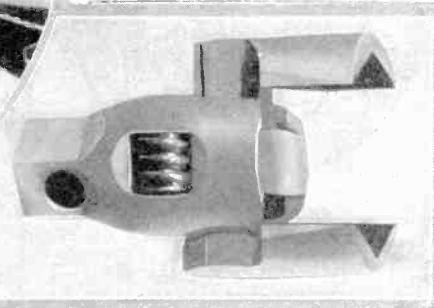

Socket wrenches have shown their extreme availability for use, particularly around automobiles. However, one of their greatest inconveniences has always been the necessity for carrying about a large kit with all the different sized sockets. This inconvenience is at last obviated through the use of the adjustable socket shown in the present illustration. Two or three of these will cover the entire range of sizes to be found on automobiles. —A. O. Cochran.

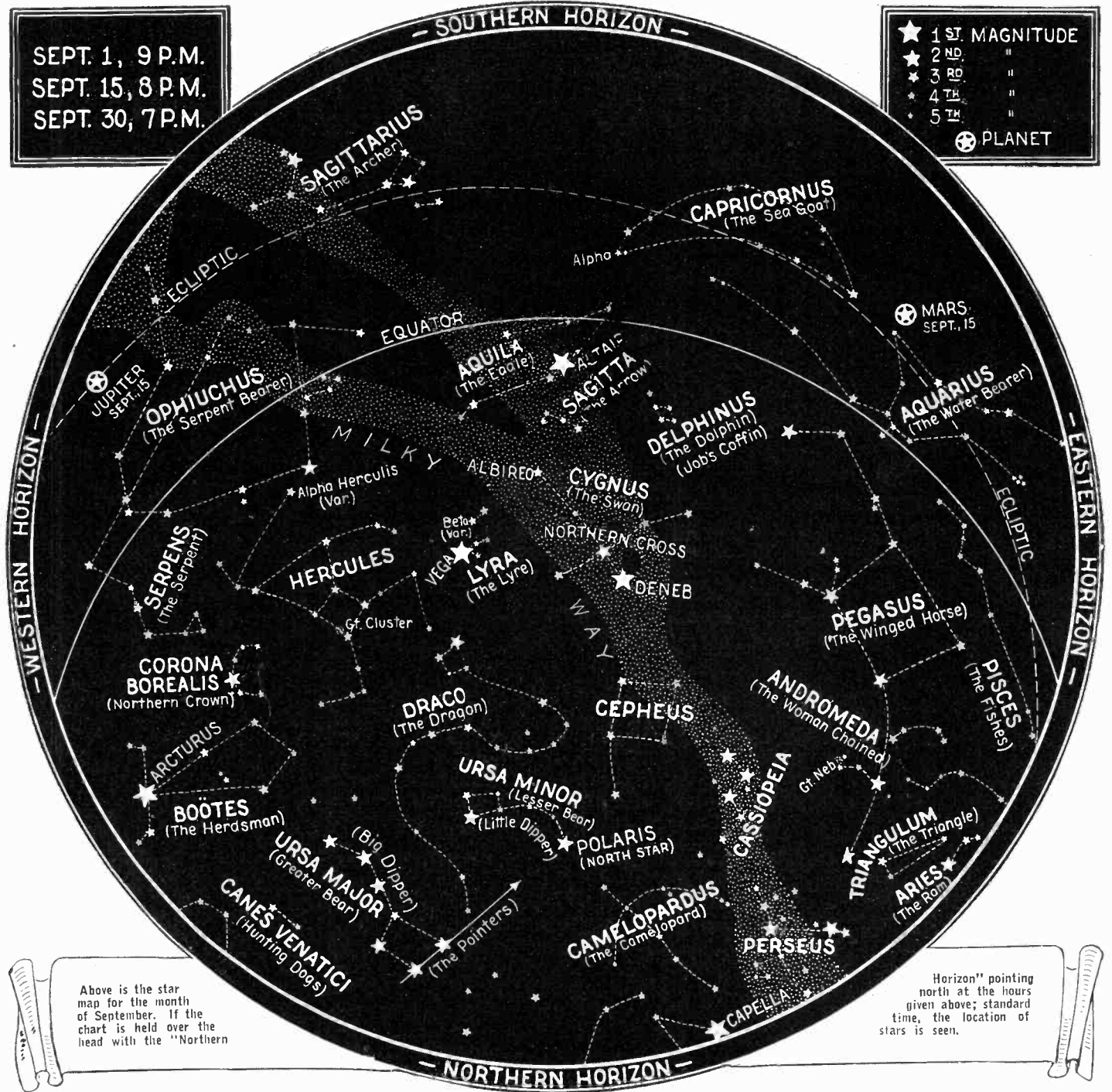

## The Heavens in September

**T**HE beautiful little constellation of Lyra, The Harp, or Lyre, will be found nearly overhead this month. Though one of the smallest constellations in the heavens it contains a number of objects of special interest. Its first magnitude star, Vega, is one of the finest in the heavens and is surpassed in brightness only by Sirius and Canopus, though Capella now coming into view in the northeast and Arcturus near the north-western horizon are but a shade less brilliant. Vega is also one of our nearest neighbors among the stars, being only twenty-five light years or one hundred and fifty trillion miles distant from the earth. The name Vega is Arabic in its origin, as are so many of the names of the stars and signifies "falling eagle." In some of the old star atlases of the seventeenth century the eagle is pictured as standing behind the harp

By ISABEL M. LEWIS, M.A.  
of the U. S. Naval Observatory

holding the star in its beak. Vega can be easily recognized by the two faint stars near by with which it forms a small equilateral triangle. The star at the northeastern corner of this little triangle, known as Epsilon Lyrae, is made up of four stars, and is known as a quadruple or multiple star. A keen eye will see this star as a double star without the aid of a telescope and a small telescope will separate each star of the pair into two stars, making a magnificent system of four stars revolving about the common center of gravity of the system. There is no record that the early Greeks or the Arabs, skilled in star-gazing, or any of the early astronomers, ever saw Epsilon Lyrae as a double star, though we

find the astronomers of a century or so ago making their ability to separate this star into two without the aid of a telescope a test of keen eyesight. This might be taken as an indication that the eyesight of the human race is improving instead of deteriorating, as some maintain. Something might be said on the other side of this question though, for how many can see without optical aid the little fourth magnitude companion of Mizar, the star at the bend in the handle of the Big Dipper, Alcor by name? Yet this is one of the widest naked-eye doubles in the heavens, the separation of Mizar and Alcor being nearly six times that of the two wider components of Epsilon Lyrae. To the Arabs Alcor was known as "The Test," and the ability to separate the two stars was considered to be a sign of good eyesight as with Epsilon Lyrae.

(Continued on page 503)

# Readers Forum

## A FAIR CRITICISM

Editor, *Science and Invention*:

As this is the first time we have written to you, we wish to tell you how much we think of your magazine. It is very helpful in many ways and is also very interesting and instructive. We are confident that it is the best magazine of its class we have seen. We think the introduction of pictorial explanation of facts a great improvement, as the number of people who learn from a pictorial description most easily, greatly exceeds the number of those who learn from verbal description, and moreover space is thus greatly saved, as it would take far more space to even give a rough outline of facts in words than the pictures take. But, nevertheless, it would be a great mistake to eliminate verbal description altogether, as a diagram, no matter of what kind, is not complete without explanation of some sort or a lettered index, and we think you were very wise to include the explanations accompanying pictures as you have.

As for the scientific romances in the numbers, we think the authors would do well to pay a little more attention to detail, as these suggest lines of thought more than general outlines do, and the stories would then be of more value to a person with a certain amount of scientific knowledge, such as would be gained in a secondary school or an ordinary arts course in college, as well as others who have not this preliminary schooling. Nevertheless, we appreciate them very much as they are. They even now give a great deal of room for thought and a basis for many interesting calculations, which without them the reader would never be led to make.

In closing, if it is not impertinent for us to do so, we wish to congratulate you on your fine magazine and we wish you every success for its future.

J. Thomas,  
R. Ringstrom,

University of Tasmania, Hobart, Australia.

## THE CHINESE AND JAPANESE DO IT

Editor, *Science and Invention*:

When you get this letter you will very likely throw it into the waste paper basket as a lot of nonsense. But I ask you to bear with me a little and think it over and I firmly believe you will agree with me that there is something in it after all.

Take a book, a "Science and Invention" for preference, on account of the illustrations in it, looking at which illustrates the point better than printed matter only, and take a glance through it. More than likely you will find that without thinking you started at the back of the book. When I open a new book casually to glance through it, I have found myself going from the back to the front of the book almost every time. It seems to me more easy and much more natural to go backward through a book than forward. Reasoning as above I came to the conclusion that it would be a great improvement to print books backward instead of forward, but the lines reading from left to right as usual, and down the page as usual. If this were done, I am fully convinced that people would find it much more convenient, especially when reading a book in awkward places, as the way we turn over a book now to read it is not nearly so convenient because it is less trouble to hold a book in an awkward position in your right hand than your left. Again, if a book or magazine were printed thus you may say people would at first find it awkward and give it up as a bad job, but nevertheless, I think people would get used to the new method in a very short time and above all the book so published, if well advertised as being so printed, would sell like an evening paper on race day on account of its novelty.

I earnestly entreat you to give this your consideration, as I am fully convinced there is more in it than there seems on first sight. Try the experiment I mentioned, and I think you will understand. I am

Reg. Ringstrom,

University of Tasmania, Hobart, Australia.

(About eighty-four people out of a hundred picked at random open a paper or book beginning at the back and glancing through to the front. Do you?—Editor.)

## FROM THE U. S. NAVY

Editor, *Science and Invention*:

I am writing to thank you for the use of the photographs of the U. S. S. *PATOKA* showing her mooring mast for the Shenandoah, and for the use of the comparative range diagram showing discrepancies between British and U. S. ships. The publication of these will, I am sure, be of interest to the public and do the Navy a lot of good. Your copyright on these will be strictly protected.

SCIENCE AND INVENTION desires to hear from its readers. It solicits comments of general scientific interest, and will appreciate opinions on science subjects. The arguments pro and con will be aired on this page. This magazine also relishes criticisms, and will present them in both palatable and unpalatable forms. So if you have anything to say, this is the place to say it in. Please limit your letters to 500 words and address your letters to Editor—The Readers Forum, c/o Science and Invention Magazine, 53 Park Place, New York City.

In the case of the range diagrams, this office has enlarged the original and I am sending a copy under separate cover for your information. This diagram has come to the attention of a number of high ranking officers in the Navy, and we are in receipt of a request for a copy of it, from Admiral Phelps, who is a member of the General Board of the Navy in Washington. This will show you how much this is appreciated, not only by this office but by the Navy in general.

Again thanking you for your valued aid and co-operation.

R. L. Berry,  
Captain, U. S. Navy.

(We appreciate this letter from Captain Berry, and wish to advise that we are at all times pleased to be of any service to the U. S. Navy and its unexcelled personnel. It is the kind co-operation of these men that enables SCIENCE AND INVENTION MAGAZINE to give its readers articles of absolute scientific accuracy. The letter from Captain R. L. Berry refers to the articles, "U. S. Versus British Gun Range" by Graser Schornstheimer, appearing in the March, 1924, issue and "Preparations Made for Shenandoah's Polar Flight," appearing in the April, 1924, number of SCIENCE AND INVENTION MAGAZINE.—Editor.)

## SMELLS ON MARS

Editor, *Science and Invention*:

In the August, 1924, issue of your excellent publication, there is an article called, "Evolution on Mars" by Mr. Hugo Gernsback, which shows a Martian having a long elephantine nose. Mr. Gernsback says in part: "Now the scant Martian atmosphere makes it very difficult to smell. Scents are propagated very slowly in a scant atmosphere. For that reason the Martian must go to the smell rather than the smell come to him. We should therefore find an elephantine nose to compensate the Martian's shortcoming in this respect."

**B**EGINNING in the next issue we will start a remarkable new serial story entitled "The Living Death," by John Martin Leahy.

This without a doubt is one of the most powerful and at the same time gripping scientific stories that we have published so far. There will not be a single installment that does not hold your undivided attention.

Not only has Mr. Leahy written a tremendous story, but the scientific data which he presents is such as to set everyone thinking. This story ranks with the best of Jules Verne. It is not only wonderfully entertaining, but the scientific facts are handled in such a way that even the layman will have no trouble in fully understanding them.

—EDITOR.

just as the elephant had to grow a long trunk in order to make it easier for him to get to his water and just as the giraffe has a long neck to reach the food he likes."

I disagree with this point entirely. I realize that odors are of two kinds. Those that are purely gaseous and those which depend upon particles of substances being thrown off by the odoriferous preparation. I am quite sure that these odors should be propagated at a greater speed in a scant atmosphere, not at decreased speeds. I likewise do not believe that the elephantine nose is necessary. The elephant's perception of smell is infinitely weaker, or at least so it would seem, than that of the modern bloodhound, and there are other animals having a more acutely developed sense of smell than even the bloodhound, yet they have no long noses.

Please explain your theory.

A Medico,  
New York City.

(Of course your theory is as good as ours. An animal may have a very long nose, which nose would be entirely devoid of sensory nerve endings. Consequently the animal would be unable to smell even very strong odors. You must admit, however, that a long nose presents a greater area for positioning of olfactory cells. You must also admit that in man the sense of smell is easily fatigued. If the chamber through which the odor passes is longer, there is a possibility that it would not be as easily fatigued. Furthermore, the Martian may use his nose for other purposes besides being a mere organ giving rise to the sensation of smell. As to the propagation of odors, let us quote from two letters, the first from Ernest K. Chapin of the Department of Physics, at the Kansas State Agricultural College, and the second from the Bureau of Standards, under the directorship of Dr. George K. Burgess. Mr. Chapin writes:

"In reply to your recent inquiry regarding the relative speed with which a gas will mix with another with different conditions of pressure, permit me to quote from O. E. Meyer's 'Kinetic Theory of Gases,' pages 249-250. 'This (theory) starts with the assumption, made also by Maxwell and Boltzmann, of the idea of a resistance to diffusion which each gas experiences from the particles of the other gas which meet it. This resistance is taken to be proportional to the densities of both gases and to the difference of their speeds of diffusion.'

"Loschmidt's observations showed that the value of this coefficient (or constant of diffusion) is inversely proportional to the total pressure of the gases, so that, as is almost obvious, the mixing occurs the more rapidly the more rarefied the gases."

"From such statements as these, which are found in all books on the subject, I take it that chlorine would, if undisturbed, mix more rapidly with thin air than with dense air and diffuse most rapidly into a vacuum since it would encounter no resistance from the molecules of another gas."

The letter from Dr. George K. Burgess, Director of the Bureau of Standards, says:

"Odors are transferred in air in two ways, by convection and by diffusion. In convection the air circulates in streams carrying the odorous material with it. In diffusion the molecules of the odorous material penetrate individually among the molecules of the air, independently of any motion of the air as a whole. Under ordinary conditions in the atmosphere, convection is more important than diffusion.

"The currents that produce convection may be caused by mechanical stirring or may result from the differences in density produced by changes of temperature. The convection produced by temperature changes diminishes when the pressure is diminished. This is because diminishing the pressure diminishes the density differences which produce convection, without greatly diminishing the viscosity which hinders convection. Hence under ordinary conditions, in which there is considerable convection produced by temperature changes, odors will be propagated less rapidly at reduced pressure.

"The process of diffusion is accelerated by a reduction of pressure and is thus influenced in the opposite way from that in which convection is influenced.

"In air which is very still, odors will be transferred more rapidly at low pressure than at high, and at extremely low pressures the transfer will be very rapid."

You can take your choice.—Editor.)

## WE STAND CORRECTED

Editor, *Science and Invention*:

Ever since reading your July number, I have intended to write you and call attention to a common error. On page 263, in THE VERTICAL REALM OF LIFE, your artist shows Mt. Mitchell as "the highest peak east of the Rockies." The following figures will be of interest:

(Continued on page 531)

# Science Odds and Ends

By T. O'CONOR SLOANE, PH. D., LL.D.

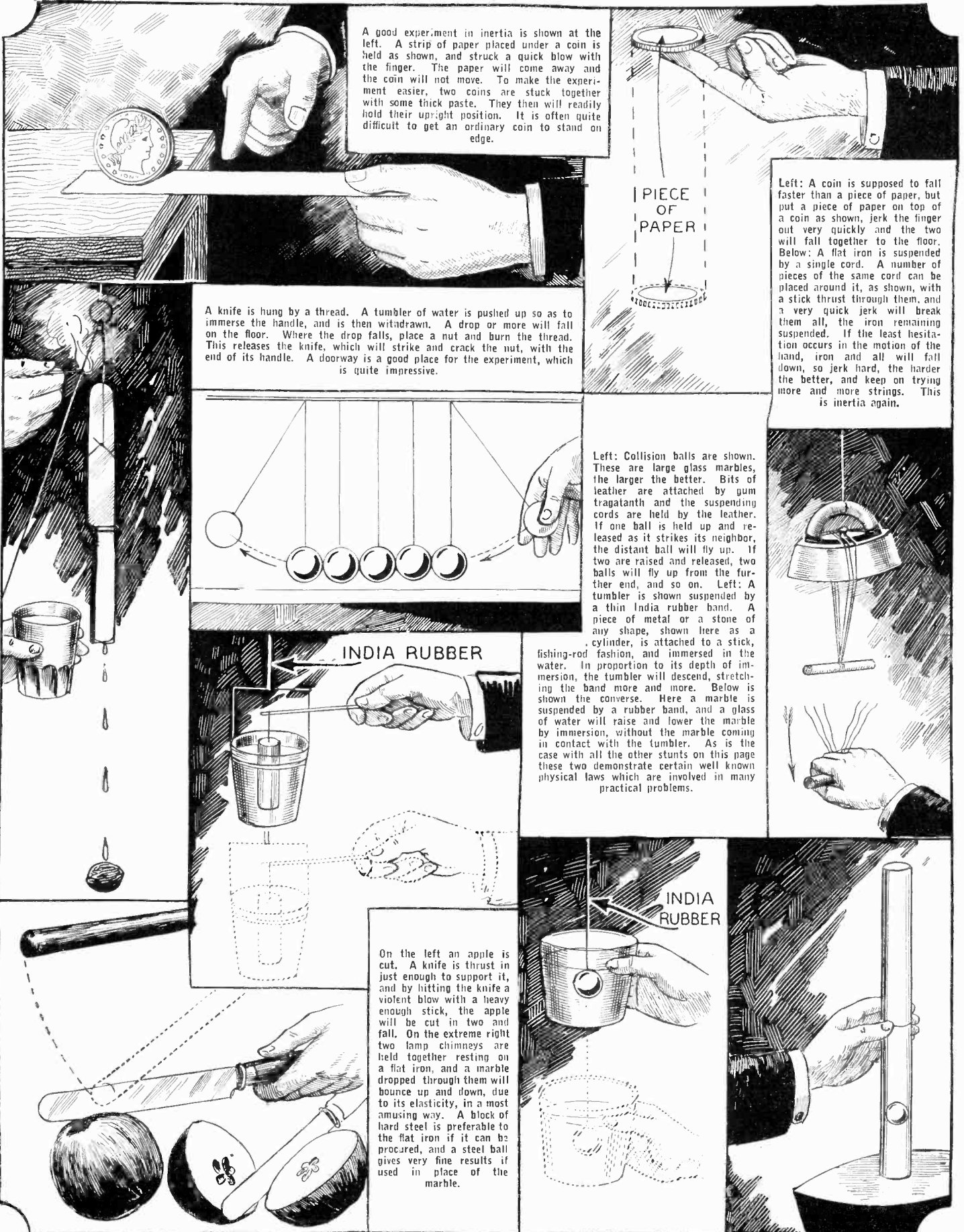

A good experiment in inertia is shown at the left. A strip of paper placed under a coin is held as shown, and struck a quick blow with the finger. The paper will come away and the coin will not move. To make the experiment easier, two coins are stuck together with some thick paste. They then will readily hold their upright position. It is often quite difficult to get an ordinary coin to stand on edge.

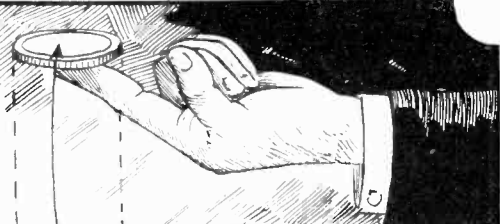

PIECE OF PAPER



Left: A coin is supposed to fall faster than a piece of paper, but put a piece of paper on top of a coin as shown, jerk the finger out very quickly and the two will fall together to the floor. Below: A flat iron is suspended by a single cord. A number of pieces of the same cord can be placed around it, as shown, with a stick thrust through them, and a very quick jerk will break them all, the iron remaining suspended. If the least hesitation occurs in the motion of the hand, iron and all will fall down, so jerk hard, the harder the better, and keep on trying more and more strings. This is inertia again.

A knife is hung by a thread. A tumbler of water is pushed up so as to immerse the handle, and is then withdrawn. A drop or more will fall on the floor. Where the drop falls, place a nut and burn the thread. This releases the knife, which will strike and crack the nut, with the end of its handle. A doorway is a good place for the experiment, which is quite impressive.

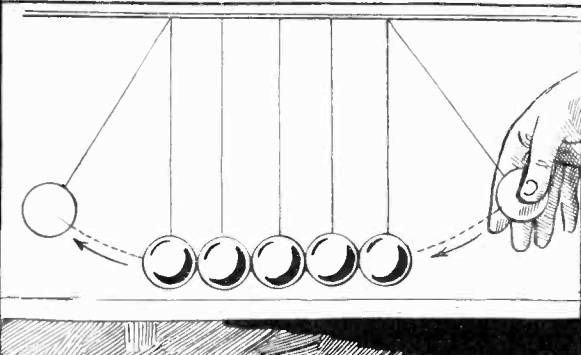

Left: Collision balls are shown. These are large glass marbles, the larger the better. Bits of leather are attached by gum tragacanth and the suspending cords are held by the leather. If one ball is held up and released as it strikes its neighbor, the distant ball will fly up. If two are raised and released, two balls will fly up from the further end, and so on. Left: A tumbler is shown suspended by a thin India rubber band. A piece of metal or a stone of any shape, shown here as a cylinder, is attached to a stick, fishing-rod fashion, and immersed in the water. In proportion to its depth of immersion, the tumbler will descend, stretching the band more and more. Below is shown the converse. Here a marble is suspended by a rubber band, and a glass of water will raise and lower the marble by immersion, without the marble coming in contact with the tumbler. As is the case with all the other stunts on this page these two demonstrate certain well known physical laws which are involved in many practical problems.

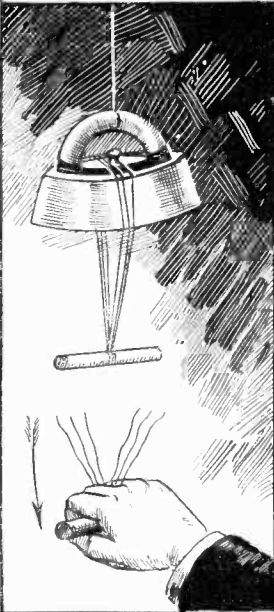

INDIA RUBBER

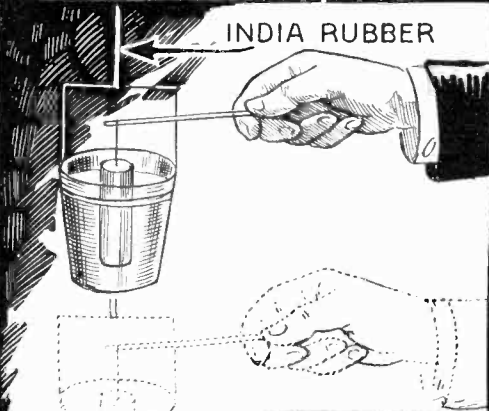

INDIA RUBBER

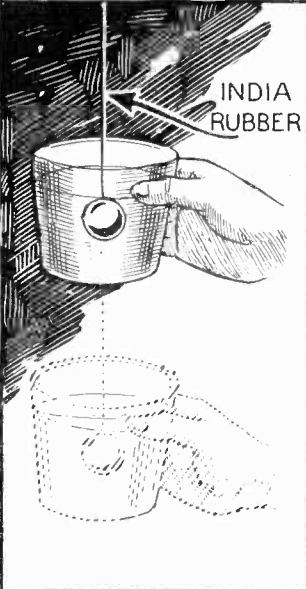

On the left an apple is cut. A knife is thrust in just enough to support it, and by hitting the knife a violent blow with a heavy enough stick, the apple will be cut in two and fall. On the extreme right two lamp chimneys are held together resting on a flat iron, and a marble dropped through them will bounce up and down, due to its elasticity, in a most amusing way. A block of hard steel is preferable to the flat iron if it can be procured, and a steel ball gives very fine results if used in place of the marble.

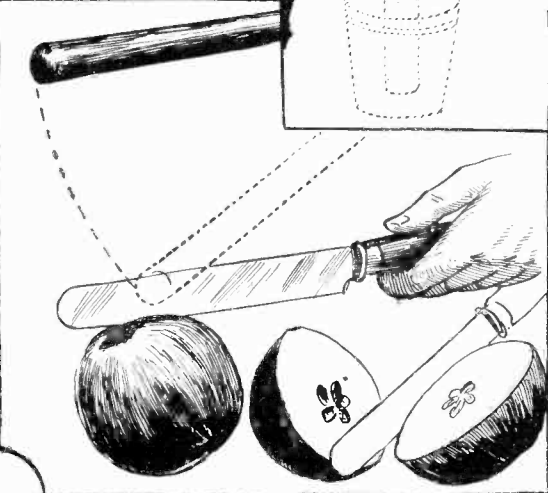

# Awards in \$100 Needle

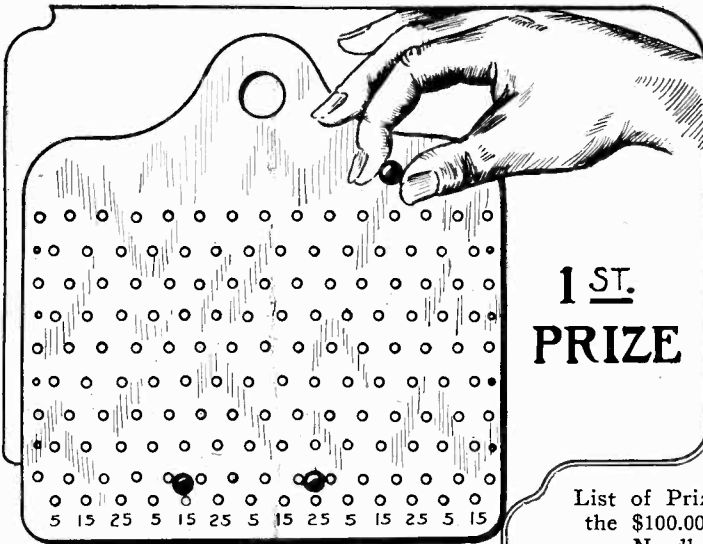

**1<sup>ST</sup>  
PRIZE**

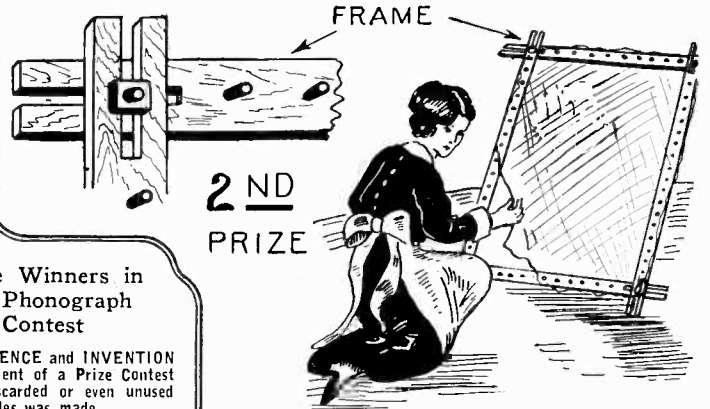

**2<sup>ND</sup>  
PRIZE**

### List of Prize Winners in the \$100.00 Phonograph Needle Contest

In the May issue of *SCIENCE and INVENTION* magazine an announcement of a Prize Contest for the best uses for discarded or even unused phonograph needles was made.

The first prize of \$25.00 was won by Francis J. Lorenz at 426 E. Seneca St., Ithaca, N. Y., for the Game illustrated above. This is made of a piece of board into which the phonograph needles are driven as indicated. Steel balls are used, each player receiving five balls (which he drops in at the top), then totalling up his score. There are no wood shelves or other retainers for the balls except the needles themselves. Although several games were entered in this contest none can compare with this for simplicity or appeal.

The second prize was won by Louis Orlando of New York City for the Curtain Stretcher illustrated above and to the right. Mr. Orlando receives \$20.00 second prize.

Mr. A. Zimmerman hailing from Toronto, Canada, wins the third prize of \$15.00 with the Check Protector idea which he submitted. He pushes phonograph needles through a piece of cardboard forming the word "exactly." This cardboard strip is now placed in a suitable holder and molten sealing wax is allowed to pour into the holder until it comes within 1/16 inch of the protruding points. By forcing the stamp down upon the check, the check is punctured with the letters or numbers on it.

The state of Kansas supplies the next prize winner, who is Marion Caldwell from the city of Eldorado. A phonograph needle is driven into the end of a small piece of wood as indicated. When the point of the needle is inserted into the bottle cap and pried upward the cap comes out of the bottle very easily. The 4th prize for this idea, an award of \$10.00, is therefore given to Mr. Caldwell.

The fifth prize of \$5.00 was won by Mr. P. C. v. Petegem of Rotterdam, Holland. He uses six needles for each plate in the wooden negative rack.

The sixth prize award of \$5.00 goes to Mr. R. J. Shryock of Lexington, Ky., for the Spark Plug Tester here illustrated. The needles insure positive contact even through a thick coating of oil. For the seventh prize, also of \$5.00, two contestants tie, consequently a prize of identical nature is given to both. The first is George R. Harding of Huntingdon, W. Va. The second is Jack Bront of Cleveland, Ohio. They both receive a reward of \$5.00 for the screw driver in a jeweller's drill holder. The eighth prize for the glass drill made of a phonograph needle was won by Mr. L. Powell of San Francisco, Calif. Mr. Powell submitted some very pleasing examples of work done with such a drill and we are glad to award him the \$5.00 prize. The ninth prize of \$2.50 was won by Mr. L. Powell again. This is a gauge made of a knitting needle to the end of which are secured phonograph needles.

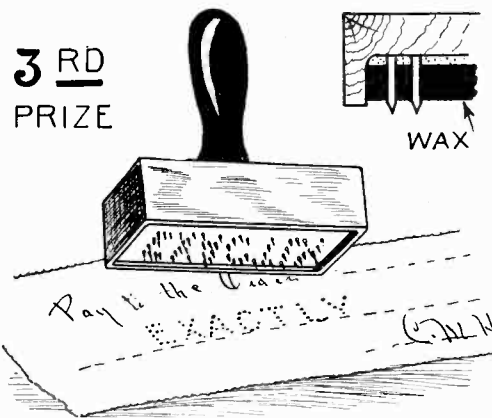

**3<sup>RD</sup>  
PRIZE**

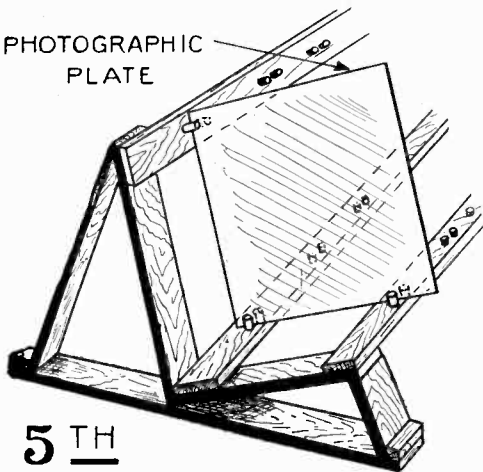

**PHOTOGRAPHIC  
PLATE**

**5<sup>TH</sup>  
PRIZE**

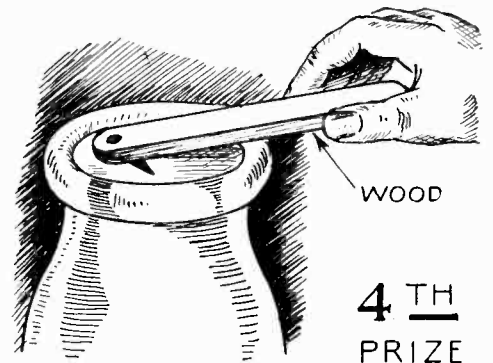

**WOOD**

**4<sup>TH</sup>  
PRIZE**

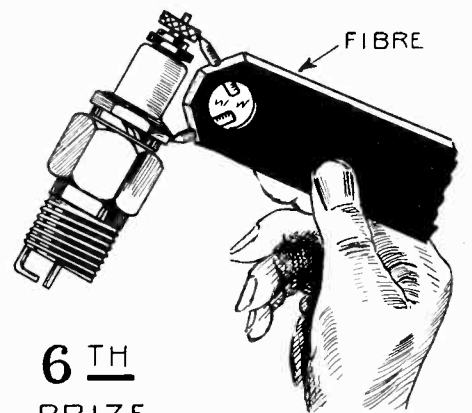

**FIBRE**

**6<sup>TH</sup>  
PRIZE**

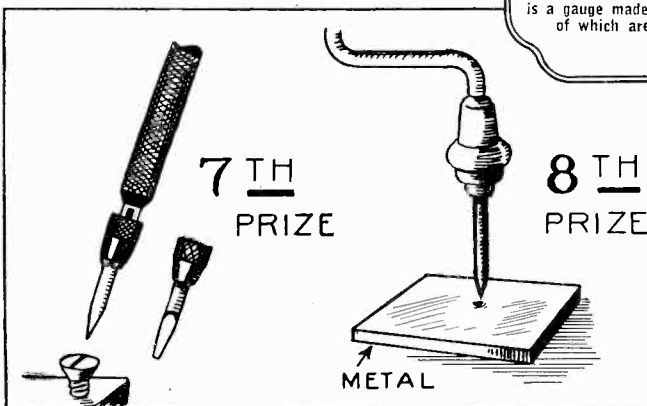

**7<sup>TH</sup>  
PRIZE**

**8<sup>TH</sup>  
PRIZE**

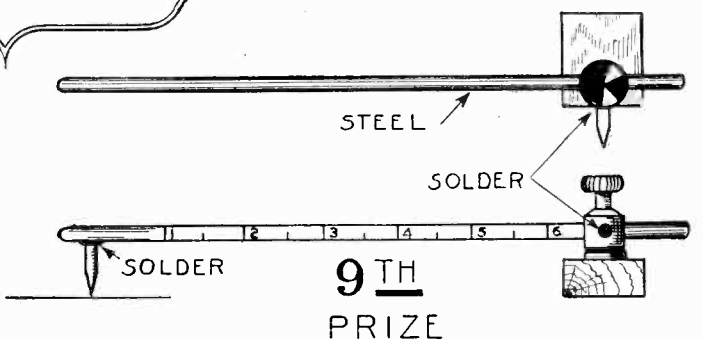

**STEEL**

**SOLDER**

**SOLDER**

**9<sup>TH</sup>  
PRIZE**



# .00 Phonograph Contest

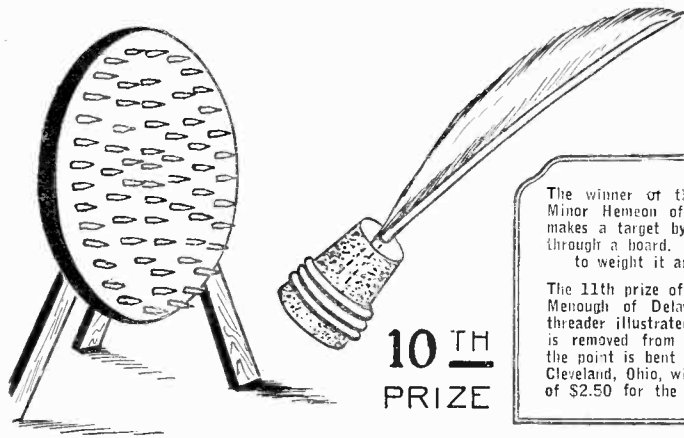

10<sup>TH</sup>  
PRIZE

The winner of the 10th prize of \$2.50 is Minor Hemeon of Nova Scotia, Canada. He makes a target by driving phonograph needles through a board. A cork with a rubber band to weight it and a feather is the dart.

The 11th prize of \$2.50 is awarded to Duane Menough of Delaware, Ohio, for the needle threader illustrated at the right. The temper is removed from the phonograph needle and the point is bent into a hook. Jack Bront of Cleveland, Ohio, wins the twelfth and last prize of \$2.50 for the magnet tester shown above.

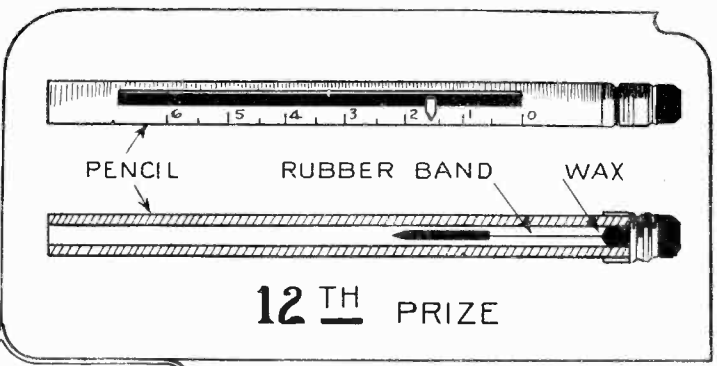

12<sup>TH</sup> PRIZE



11<sup>TH</sup>  
PRIZE

## Honorable Mention

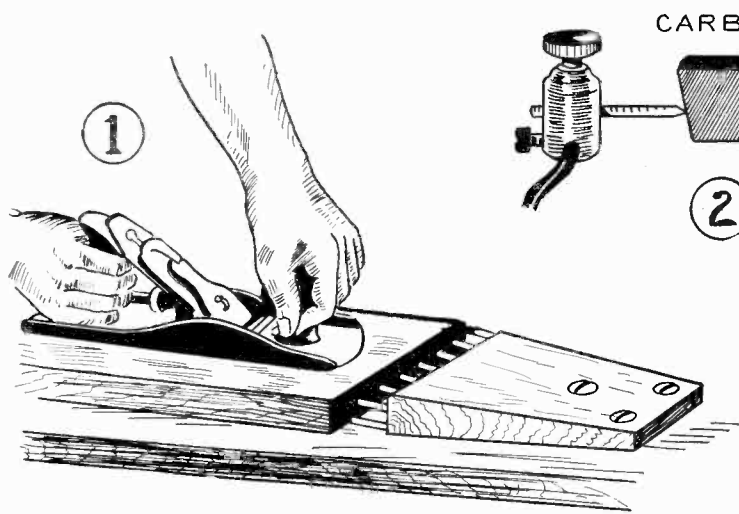

1

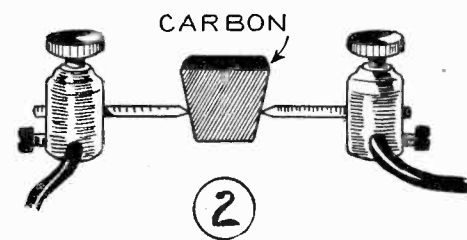

2

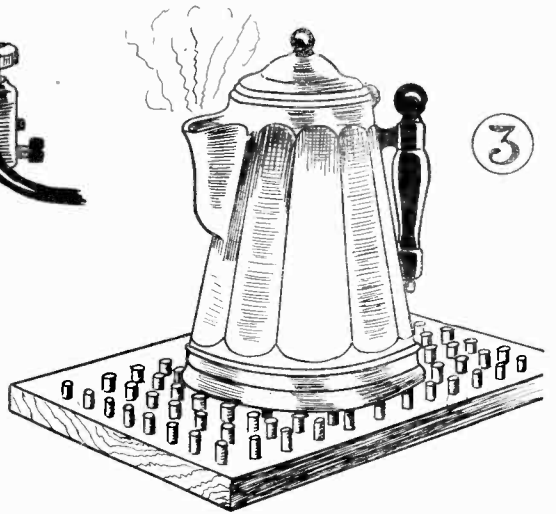

3

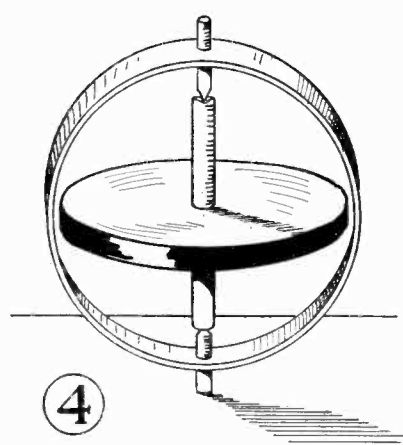

4

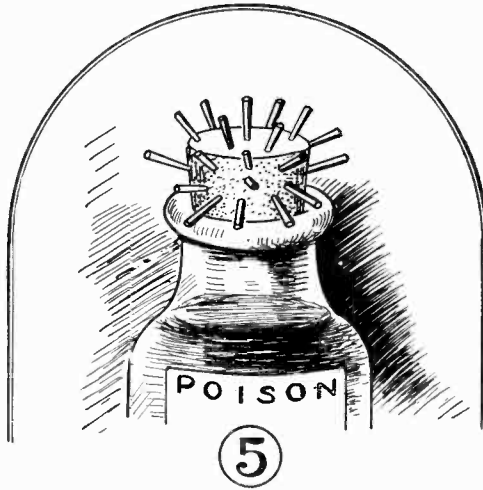

5

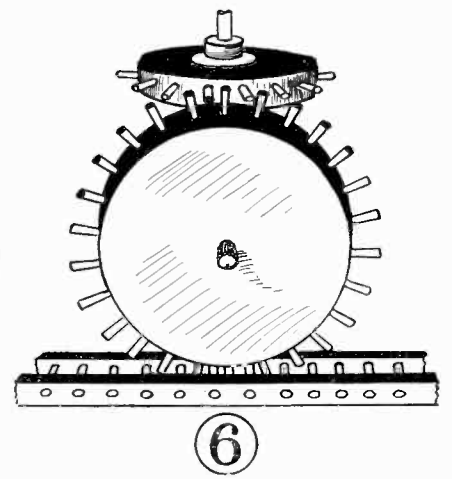

6

The first honorable mention is for the Bench Stop shown in Fig. 1 and goes to Leighton Powell, Reporter No. 8621, San Francisco, Calif. Paul Brietwich of Chicago, Ill., wins the second honorable mention with the microphone shown in Figure 2. The third honorable mention shown in Figure 3 is the Hot-Pot Holder. This was entered by Andrew Farina, Kamloops, B. C., Canada. The idea for Gyroscopic bearing shown in Figure 4 was also submitted by Jack Bront, whose name was previously mentioned. This suggestion gets fourth honorable mention. The fifth honorable mention for the Poison Bottle Top shown in Figure 5 goes to Olin Alvin Williams of Americus, Ga. It might be mentioned that Mr. Williams won the first prize in the Cigar Box Contest previously run by this magazine. Another fifth honorable mention for the same idea was awarded to D. B. McRae, Salt Lake City, Utah, and a third fifth honorable mention for the same suggestion to C. R. Mullin of Minneapolis, Minn. The last three mentioned names from different parts of the country submitted the same suggestion and tie for the honorary award, the gear and gear rack indicated in Fig. 6. The eighth honorable mention is awarded again to Mr. C. R. Mullin of Minneapolis, Minn.



# THE CONSTRUCTOR



## Canvas Canoe Construction

**T**HE construction of the canoe shown in this article is extremely simple and may be carried out very easily. The length must first be decided upon. Fourteen feet will be ample for two persons. It may be shorter if only one person is to use it, or longer if more than two are to be carried. A good grade of cypress is used throughout. The keelson is first laid, and may consist of a strip of about three-quarters by one and three-quarters inch stock. To each end a stern and bow piece is attached, which are made of 5/8" stock. They are held in place by screws. Immediately behind these pieces, the bulk heads are placed. They are cut according to pattern shown at B. Bulk

heads and cross braces are all notched, as at F. Cross braces are made by gluing and fastening three pieces of stock, as shown at C, bracing them with angle irons. Next the rib bands are bolted to the bow and stern pieces and tacked to the cross braces. These braces are 1/4" by 1 1/4" stock, a little longer than the canoe length. The front portions should be soaked in hot water before application, so that they will be pliable. The canvas is then stretched over the frame in one piece, tacked to the keelson, rib bands and gunwale. The keel is then nailed to the bottom of the keelson. The canvas is painted with about three coats of paint rich in oil. —Dr. Ernest Bade.

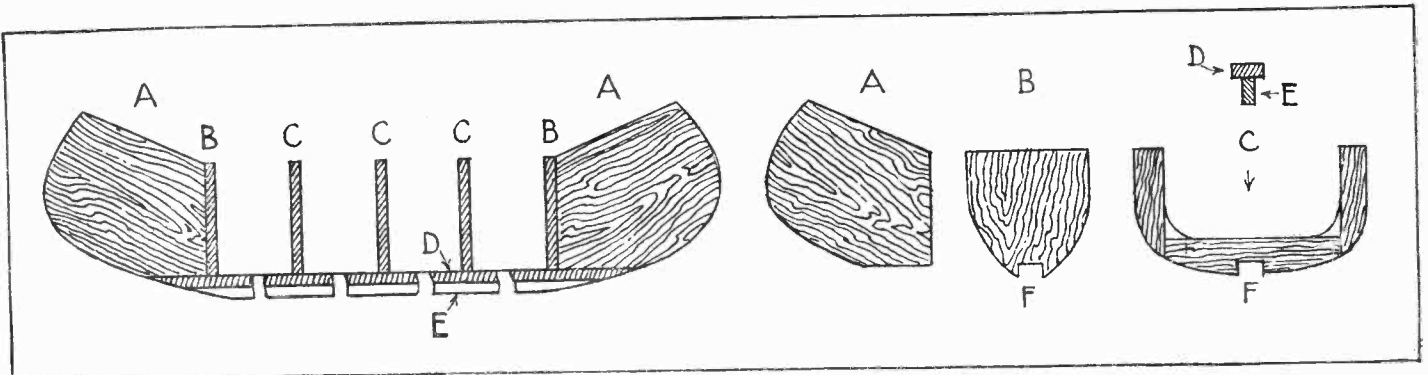
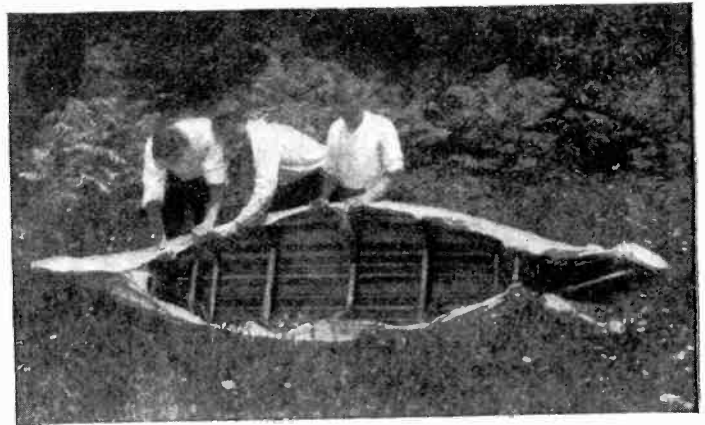
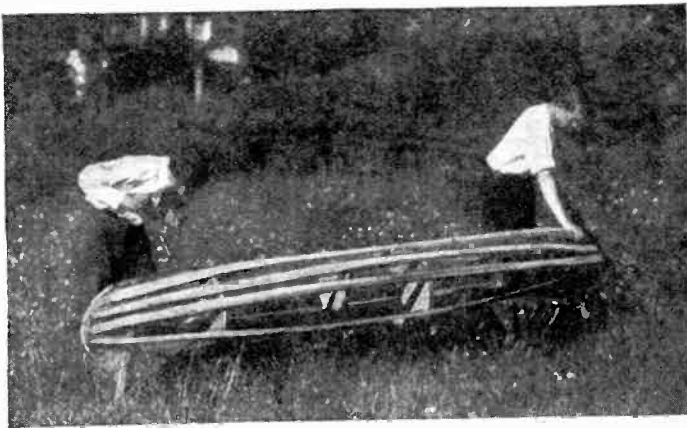

## Uses for Broken Tools

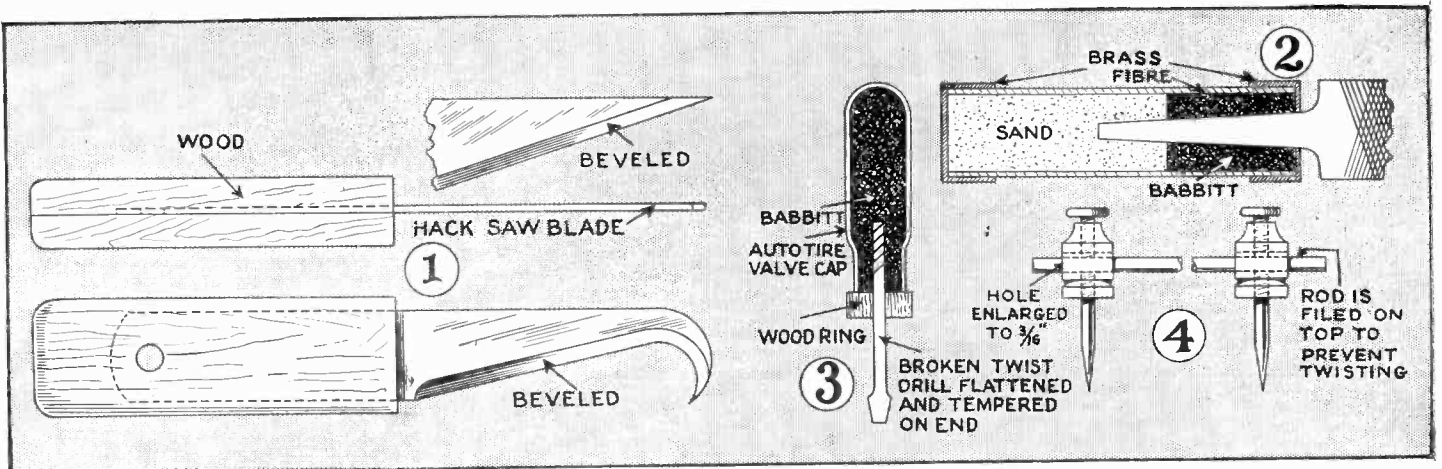

A hack saw blade cut as at 1 and equipped with a handle makes an excellent tool for cutting linoleum or roofing paper. An old fuse plug filled with sand and babbitt serves

well as a file handle, while a broken drill, a little babbitt and an auto tire valve cap make a screw driver. Binding posts are good trammel points, see Fig. 4. —T. B. Sage.

# Uses for Old Spools

By WALTER MARKOWSKI

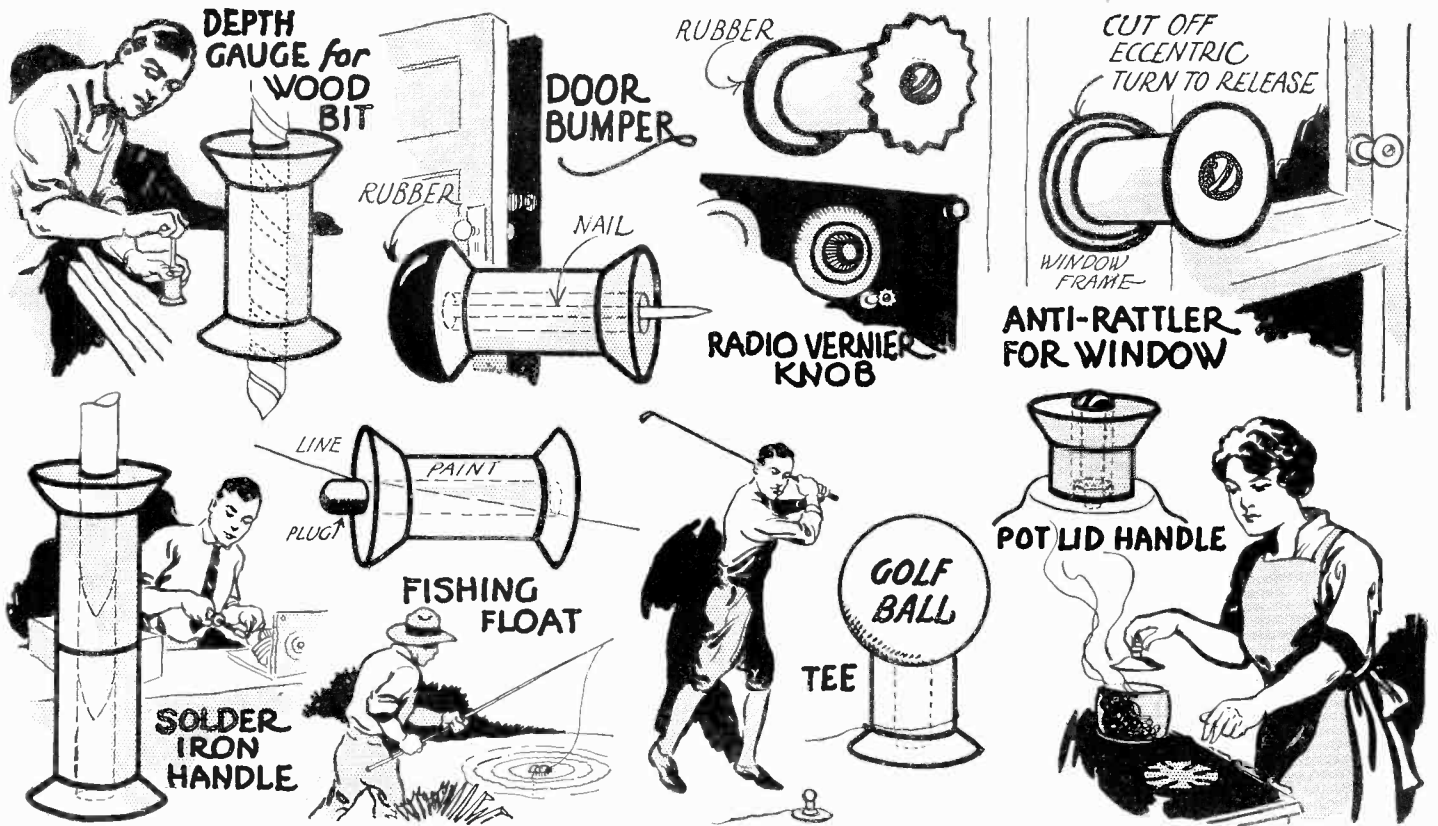

Old spools can be put to so many uses that one really wonders why they are thrown away. These suggestions shown in the illustration above do not complete the number of purposes to which empty spools admirably lend themselves. The enterprising reader will find no difficulty in discovering other useful applications. In the anti-

window-rattler shown one side of the spool is cut off eccentrically and then the spool is mounted near the window frame. By turning it, a wedge-like fit is produced between window sash and frame so that it will not rattle. As the fishing float the line is passed through the center of a spool and held in place by a wooden plug.

## Hose Kink

## Microscopic Drawing

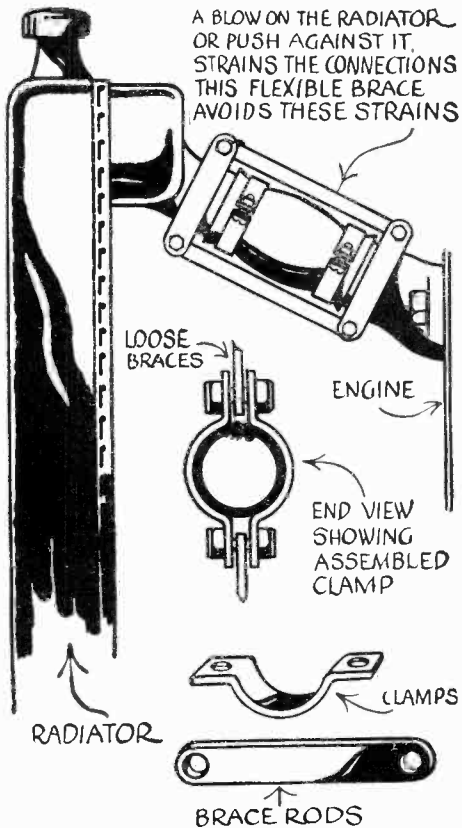

An elastic brace to prevent the straining of the hose connections leading to the radiator of a car is simple to construct. It will prevent the radiator from working loose by linking it with the engine.

—G. A. Luers.

Micro-photography is sometimes a difficult and expensive process. Many times the details most desired are lost. In the method shown above, those particular parts which are wanted may be drawn and colored. Coloring is a beauty unobtainable with the photographic methods. A compound microscope is placed on its side. A small piece of mirror is then fastened to the eye-piece with wax. This mirror should be at an angle of 45 degrees with the eye-piece. Both eyes are open and the operator looks into the mirror. The image greatly magnified will appear to be actually on the paper, and its outline can readily be traced.

—Prentice E. Tugardin.

# Hairpin Surgical Instruments

## Nature of Pin Lends Itself Well to First Aid Work

By W. C. MICHEL

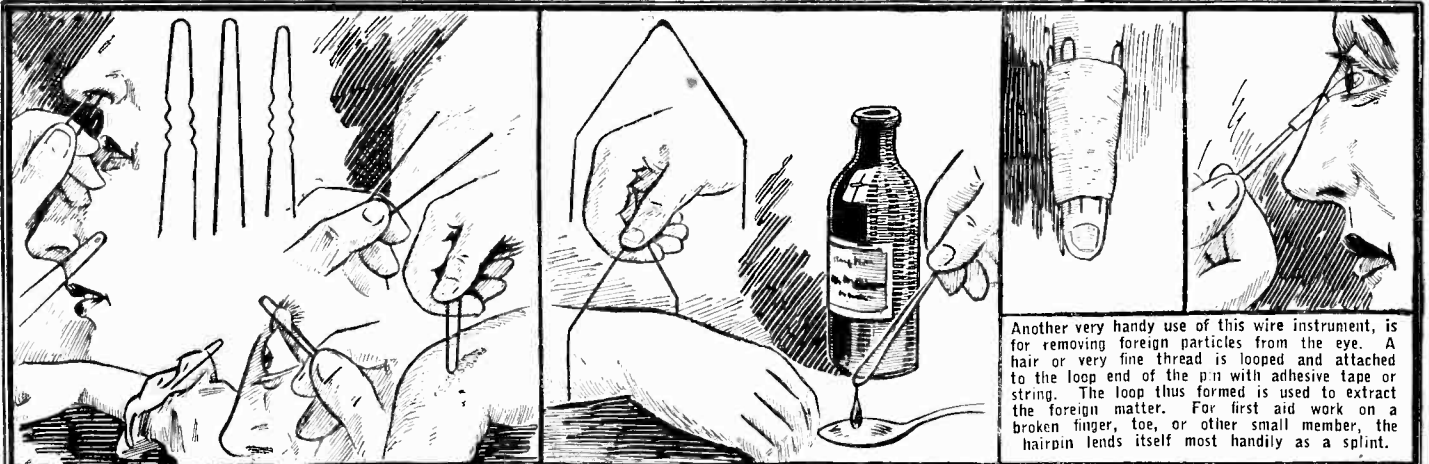

Because of its ability to be thoroughly sterilized, the hairpin lends itself conveniently to a number of medical purposes. Above it is shown being used to remove foreign objects from the nose or ear, for holding the eye-lid open, and for squeezing small boils and scratching away scar tissue.

A hairpin is bent as shown at the left of the above illustration, and used as a pair of calipers for comparing the swelled member with a member in good condition. If the loop of the pin is bent together, it makes an excellent medicine dropper.

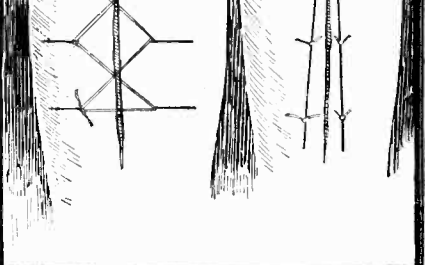
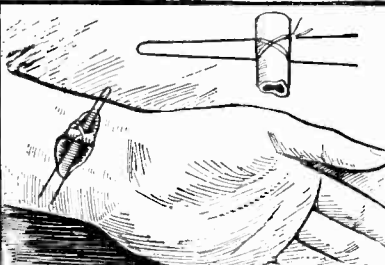
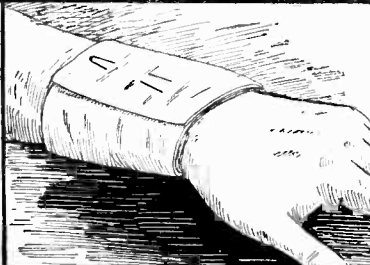

Placed as shown the hairpin is most effective in stopping a slight nose bleed.

In default of safety pins or other binding material the hairpin is especially good where the wound to be bound must be left dressed lightly.

When a cut ruptures a blood vessel, the pin may be inserted under the vessel and a figure-of-eight ligature is lashed around the pin and the vessel.

For long slits and cuts where the lips of the wound must be held together. The hairpin is supplemented by silk thread or catgut. The pin must be sharpened, if used as shown at the left.

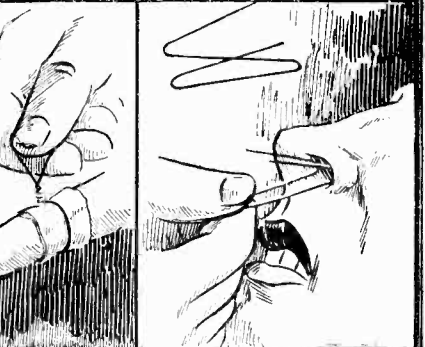
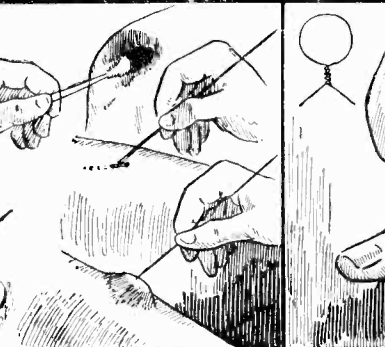
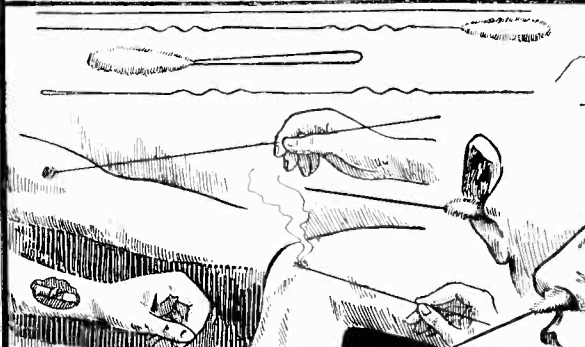

Here is shown a number of small but very important uses. With a bit of cotton wound around its end, an excellent swab is formed. By heating the end, it makes a cauterizing instrument. If one end is sharpened flat, it serves as a tenaculum for scraping foreign matter out

of wounds. The other end of the same pin may be filed to a round point and used for opening boils and blisters. Its flexibility is a help rather than hindrance and the wave shape of its sides serves as a handle, enabling the person using it to grip it firmly.

A hairpin properly twisted may be made to serve any purpose. A most handy tourniquet is made by simply twisting the hairpin in place of the regular instrument as shown. Also, bent in the form illustrated above, at the right, it can be used for holding the nostrils open when work in them is necessary.

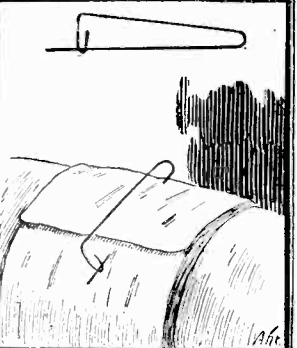
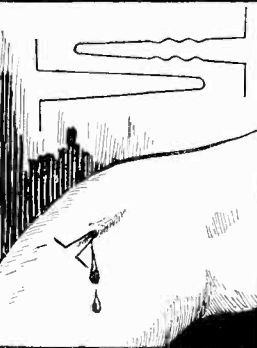
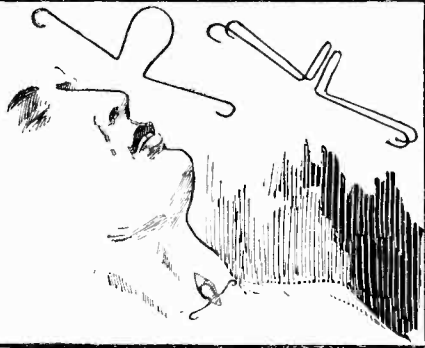
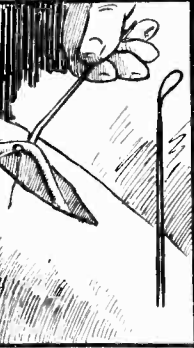
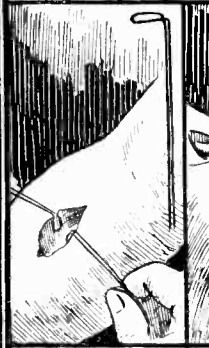

Bent in the shape shown directly above, an almost perfect retractor is made. Many times bad wounds must be held open or a blood vessel must be raised from an open cut in the process of treating it. A slight loop on the end in the pin in the form of a hook allows its use in this position.

In dressing some peculiar wounds, such as those of trachea, it is necessary to hold the wound open for some time. In such cases a single hairpin or two bent in the shape shown at the top of the above illustration, fit in and perform this necessary function.

In other wounds it is necessary to keep them open so that there will be a free passage for pus during the early stages of healing. A bent hairpin acts here very well. In a pinch, bent as shown in the right illustration, the hairpin can be made to serve as an excellent safety pin.

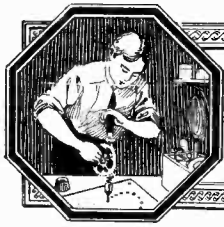

# HOW-TO-MAKE-IT

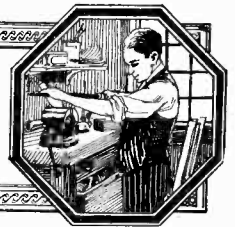

This department will award the following monthly prizes: First prize, \$15.00; second prize, \$10.00; third prize, \$5.00. The purpose of this department is to stimulate experimenters toward accomplishing new things with old apparatus or old material, and for the most useful, practical and original idea submitted to the Editors of this department a monthly series of prizes will be awarded. For the best idea submitted a prize of \$15.00 is awarded; for the second best idea a \$10.00 prize, and for the third best a prize of \$5.00. The article need not be very elaborate, and rough sketches are sufficient. We will make the mechanical drawings. Use only one side of sheet. Make sketches on separate sheets.

## Coop Lock

FIRST PRIZE \$15.

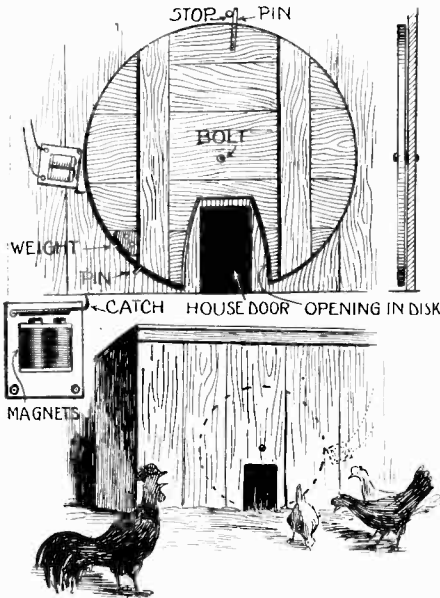

The head of a barrel to which a weight is attached, an electro-magnet, the armature of which is equipped with a hoc; and a bolt, make an excellent automatic opening chicken coop if they are worked together, as shown in the above sketch. The weight rotates the door to the open position, as soon as the electro-magnet is energized, releasing the catch.

—L. B. Robbins.

## Waste Oil Burner

SECOND PRIZE \$10

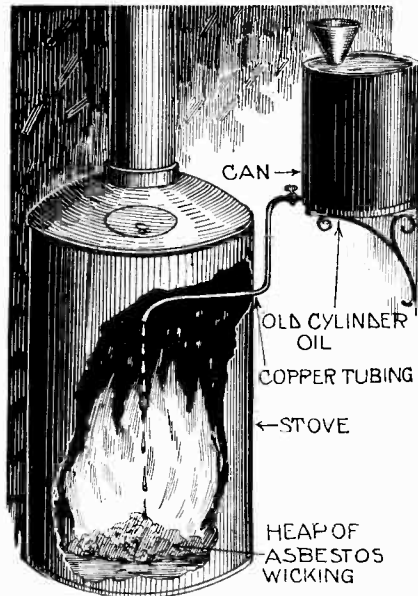

Waste oil may be burned with advantage through the method depicted above. A heap of asbestos wicking is thrown on the grates. The oil container is placed above the stove, and a small pipe carries the oil into the top of the stove, allowing it to drip on the wicking. The pet-cock controls the rate of flow.

—Leslie J. Smith.

## Spirit Picture

THIRD PRIZE \$5

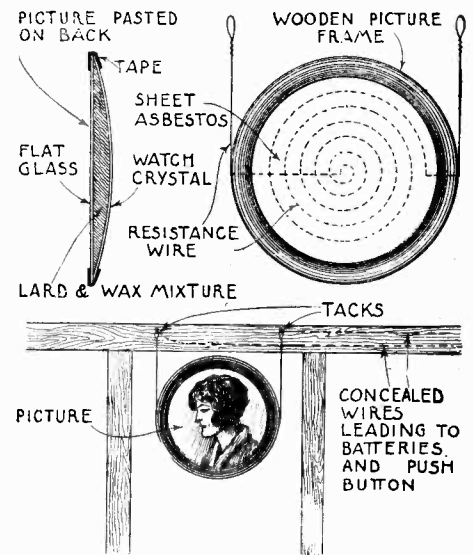

A photograph or view is pasted to a piece of thin circular glass. Over this is placed a four inch watch crystal, and the space between them is filled with a mixture of lard and soft white wax. The two are then taped together. On the back of the rear glass a coil of fine German silver resistance wire is wound and terminated in two loops. A current passed through the wire heats and melts the wax, making the picture visible. Upon cooling, the picture again disappears. This is a good parlor stunt.

—Chas. D. Tenney.

## Clip Kink

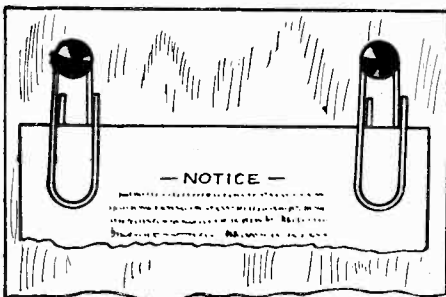
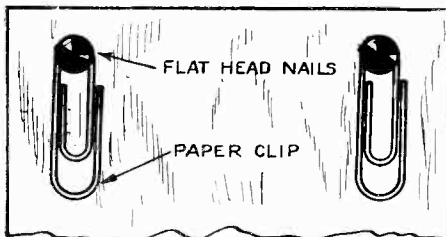

Where a great many notices are to be posted on bulletin boards, the trick illustrated above will come in exceptionally handy. Two ordinary paper clips are held to the board by flat-headed nails or large thumb tacks. The notice is then simply slipped into the clips.

—Wilson Walters.

## Warning

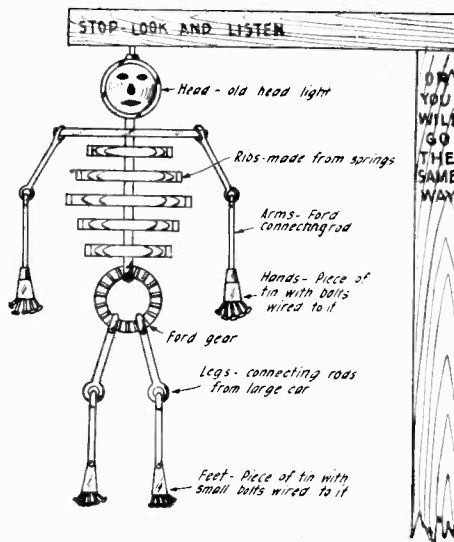

One of the most novel methods of calling the attention of passing motorists to dangerous grade crossings, cross-roads or dangerous curves is a sign such as the one shown in the above illustration constructed from old automobile parts. It very eloquently conveys a message, which all the signs made of words known to man would never "put across."

—Lyman Mason.

## Microscope Kink

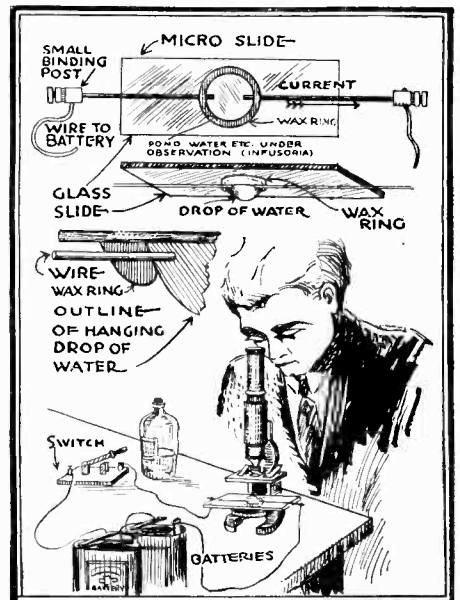

In observing the infusoria of water, the small bodies many times pass out of the range of observation. The two wires leading a current into the water, and attached to a small battery, may be used to electrocute them at the proper moment, thus making observation much easier.

—C. A. Oldroyd.

# WRINKLES RECIPES & FORMULAS

Edited by S. GERNSBACK

## Bleacher

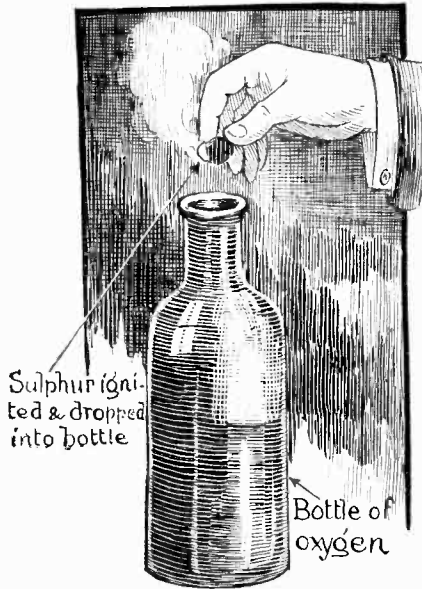

Process of Making Sulphuric Acid.

IF a bit of sulphur is ignited and plunged into a bottle of oxygen, the bottle will be speedily filled with fumes of sulphurous acid gas, which has powerful bleaching properties. If wet flowers, or damp red cloth, are held over the mouth of the bottle, the colors in them will quickly disappear. If care is used, this bleacher can be used to advantage around the household. The experiment may be performed very easily by using a large bottle as a container for the oxygen and only a small piece of lighted sulphur need be used. Every experimenter has the apparatus around his laboratory for making the oxygen, and has no doubt prepared it many times, so no details will be given here for its manufacture.

—C. Guer.

## High Pressure Hydrogen Generator

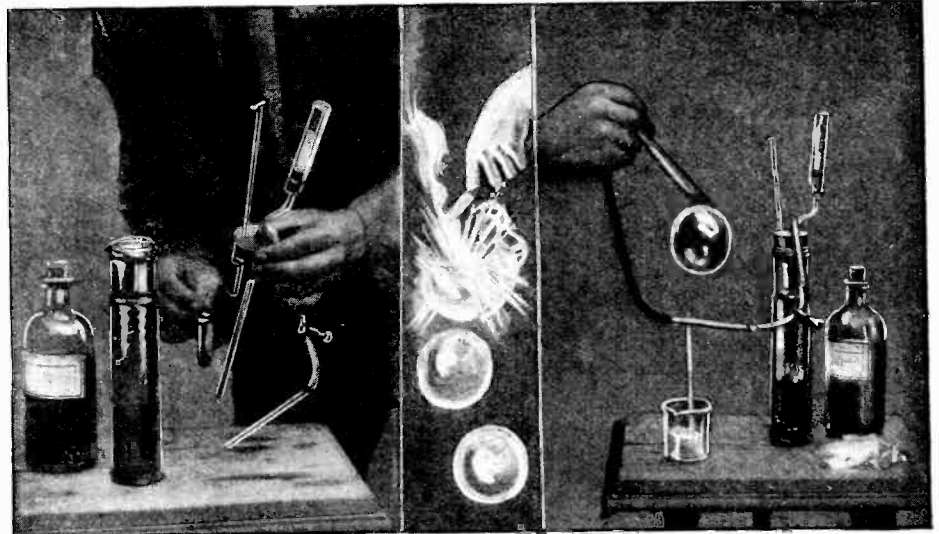

Above is shown the apparatus and arrangement for the high pressure hydrogen generator. It is the most economical and safest means of generating gas for the amateur.

A SIMPLE, and effective way to produce hydrogen, is by means of a chemical generator using zinc or iron and acid. The only apparatus needed is an olive jar, a three-holed and a one-holed rubber stopper, a vial, test tube, glass rod and tubing and some lead wires. A piece of the glass tubing is passed through one hole of the three-holed stopper which must fit the olive jar, and one end is bent into a handle and the other lower end into a hook. Then the test tube is carefully heated and five or six holes punctured through its bottom. The lead wire is bent around the tube and hooked on the glass rod. A second piece of glass tubing about

two inches longer than the bottle, is passed through the remaining holes of the jar, and the vial with the one-holed cork placed on the upper end as shown. A delivery tube goes in the third hole of the main stopper. To operate, fill the test tube with iron or zinc and the bottle with sulphuric acid dilute about four water to one acid. The test tube is slowly lowered into the acid until acid just enters the first hole. Gas generation is controlled by raising and lowering this tube. A bit of copper sulphate dropped into the generator will improve its action.

—Dr. Ernest Bade.

## Feather "X-Ray"

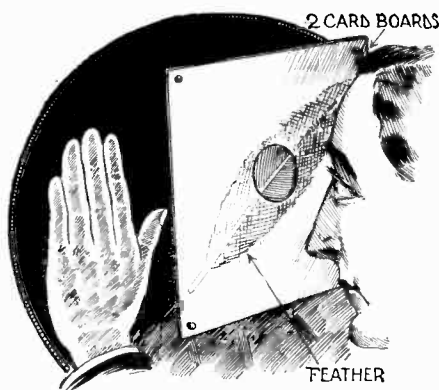

A well known optical illusion may be performed with the assistance of a feather and a couple of pieces of card-board. A clean regular feather is taken, as shown in the illustration, and placed upon a piece of card-board, in the center of which a hole has been cut. On top of this is placed a second piece of card-board similar to the first, and the two are fastened together. If the hand or a pencil is viewed through the feather, most astonishing results will be manifested.

—Frank R. Merre.

## Graduate Kink

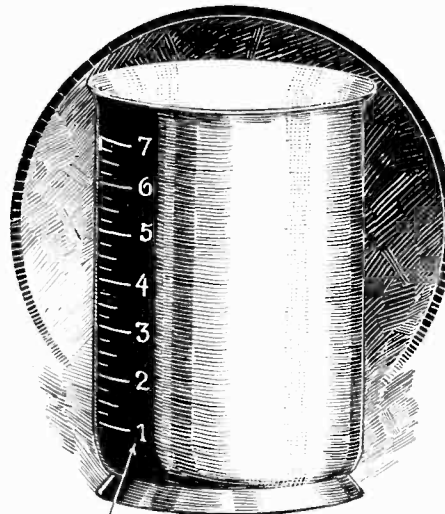

### LUMINOUS PAINT

For working with graduates in dark rooms or with black liquids, procedure will be greatly facilitated, if the numbers and markings on the graduate are painted with luminous paint, as shown in the illustration. In fact this kink will be found most handy to any experimenter, since the red or black markings usually on the graduates are hard to read.

—J. H. Paulson.

## Pen Lamp

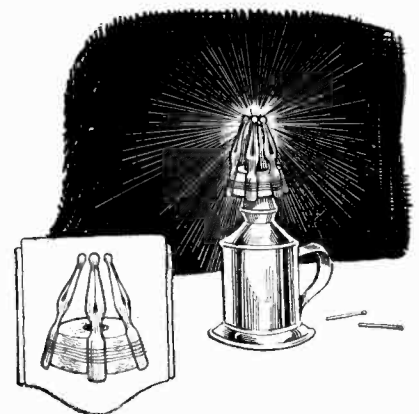

Take four pen points and secure them around a cork with a hole in the center, as in the drawing. Take a match, place it over a lighted spirit lamp and allow it to burn for a few seconds. Then extinguish it and you will find at the point of it very fine white ashes. Place some of these ashes at the points of the pens. When the lamp is lighted again a very vivid bright light will result.

—Ben Zyl.

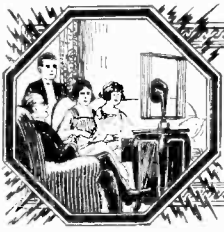

# RADIO

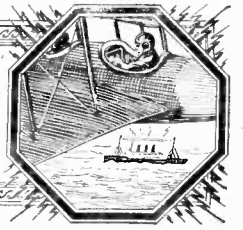

## Telegraph Circuit Receives Radio

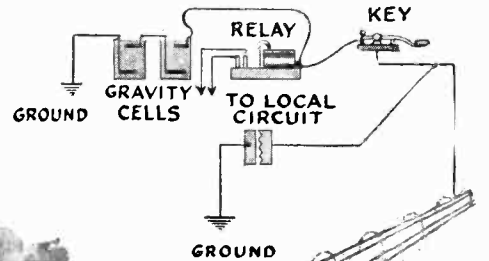
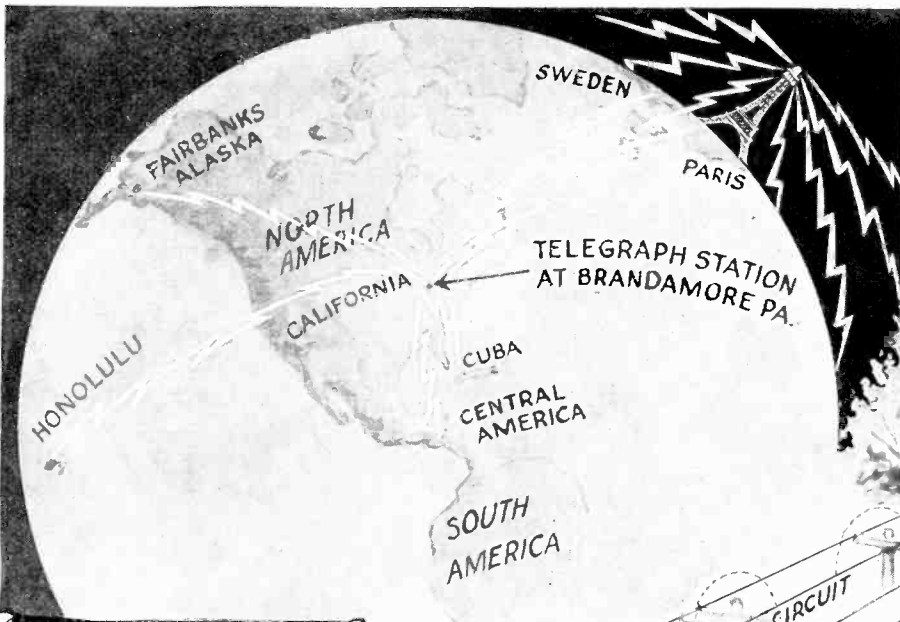

WIRE TOUCHING TREE

The sketches at the bottom of the page show the simplest radiophone receiver and how the longer waves are favored by the long antenna, while the telephone takes the audio-frequency rectified signals from the oscillating circuit.

One peculiarity which tends to form a hypothesis for this phenomenon is the fact that if short wave stations are being received and a long wave station begins to transmit, the former is forced out; the circuit picking up only the latter. The longer wave is nearer the aerial's period.

SITTING alone in a small telegraph station on a railroad down in Pennsylvania, E. D. Boyer, a telegraph operator, was surprised to hear over his telephone receiver a voice say, "This is station FL, Eiffel Tower, Paris," in French. Following this, upon other afternoons, through the same system he heard voices from the palm-lined beaches of Honolulu, from frozen Alaska, and the plains of South America. At other times messages in voice (never music, which filters out) were heard with nothing but the armature of the relay as a reproducing vibrator. Engineers from all over the country have investigated this phenomenon and found it to be true, but have not brought forward any thorough explanation. The sketch shows the arrangement of the telephone and telegraph lines running parallel for about seven miles, and the various connections of lightning arresters and batteries at either end of the lines. Our explanation is that the telegraph line acts as a long antenna (of the Beveridge type), while a tree touching it, or the batteries connected to the line, function as electrolytic rectifiers, generating an audio-frequency current in the line, which is induced in the telephone line with the receiver.—Thanks to Prof. Eugene Bobrowski.

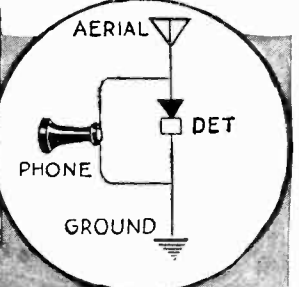
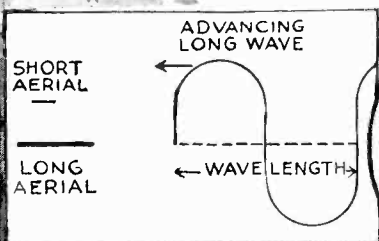
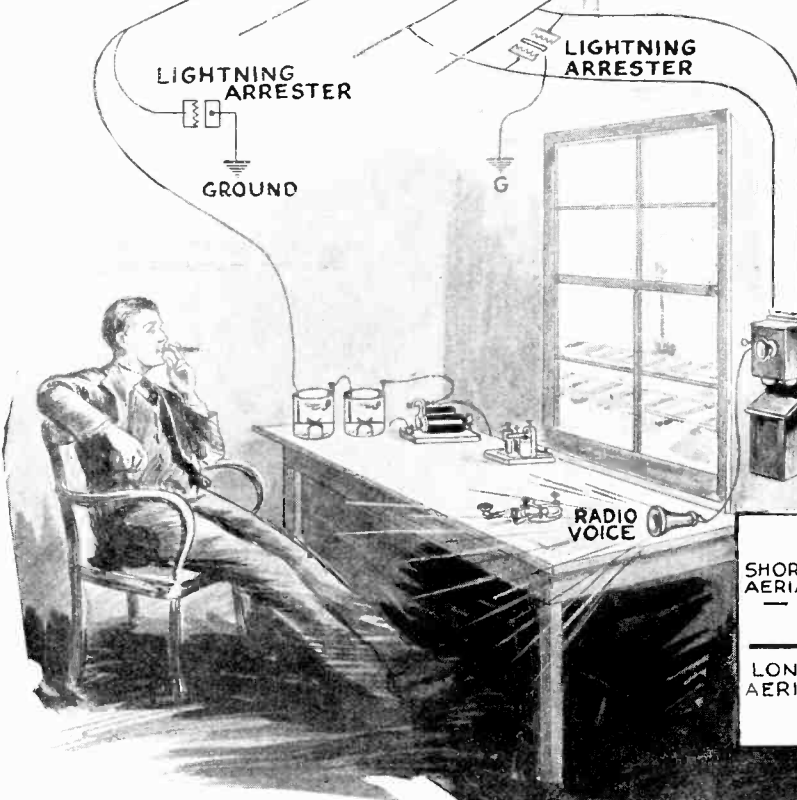

# How Radio Drama Is Made

New Art Developed at Station WGY

WITH the introduction of the movies, a whole new system of drama was necessitated. With no voice to carry the development of the plot, many refinements in acting were incorporated. So with radio. The first step in the direction of evolving a new art—radio drama—has been made by the General Electric Company's station WGY, located at Schenectady, N. Y. Since the listeners do not have the advantage of the usual stage sets, scenery and business, it is necessary that every use be made of sounds to portray the dramatic intent of the words and actions of the characters, if the emotional properties of the new art are to pass above the stage of a bed-time story. The illustrations on this page show the first developments. True, a good many of them are copied from standard stage practice. However, even these must be adapted to the peculiar nature of radio. Their first attempts showed a fair amount of success, as demonstrated by the large number of laudatory letters received by the station after their first essay into this new art.



HOW THE SCENE IS PRODUCED

FIG. I

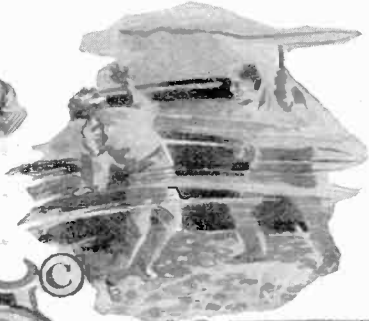

ONE IMAGINES THE ACTION GOING ON IS AS SHOWN IN SCENES "A" "B" "C" AND "D"



EFFECT OF RAIN FALLING — OBTAINED BY ROLLING PEAS THROUGH PAPER TUBE



FOREST FIRE EFFECT OBTAINED THUS

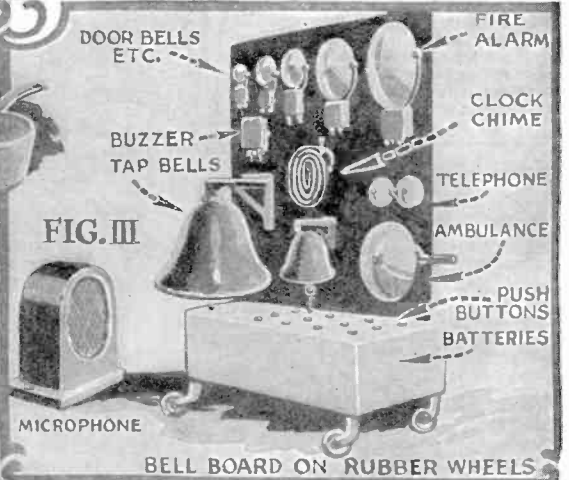
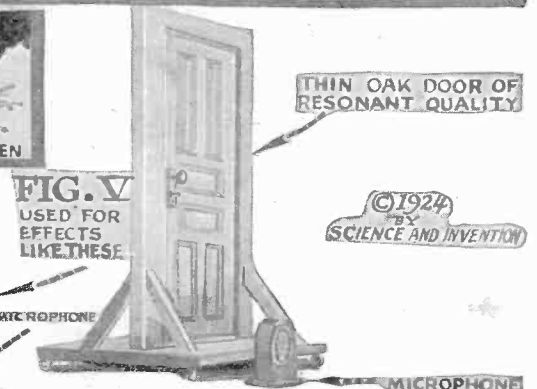
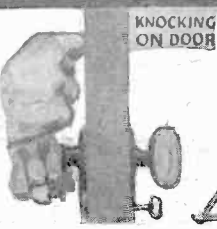

©1924 BY SCIENCE AND INVENTION

The upper part of the illustration, Fig. 1, shows the simplicity with which a scene is produced. The audience, however, gets all the thrill of a good old-fashioned melodrama through one sense only, namely, their hearing. The hero is shot from ambush. He falls and feigns death. His assailant comes from hiding to look at his victim. Immediately the hero is on him. They fight in the autumn leaves which are on the ground. Shortly the heroine rides by. The hero gains the upper hand, and they ride away to other adventures. Many of the actions, as will be seen, are carried out to some extent. The struggle in the studio is performed in a large batch of onion skin

paper to give the effect of rustling leaves. The various noises of men struggling are given with a touch of realism, since two actors do really tug at one another manfully. The girl sitting atop the piano plays galloping horses with two wooden sticks. Rain is a simple matter to produce. Dried peas are simply poured through a bit of pipe in front of and close to the microphone. There are any number of bells shown in Fig. 3 used in the productions. Fig. 4 shows the method employed to create the sensations of a forest fire, while Fig. 5 shows complicated movements and microphone settings necessary for the simple business of leading one character in or out of a room.



# Philadelphia's Radio Entertainers

All radio fans living in the eastern part of the United States are acquainted with the call letters WOO, which is the sign of the Wanamaker store in Philadelphia. At the left is given a good photograph of the business end of that station as it appears while one of their programs is being put on the air. The control board seems unimposing when the strength and range of the signals emanating from it are considered. However, the half-kilowatt which it controls manages to create quite a splash in the ether, in spite of the simplicity of the layout. Such a splash does it initiate, in fact, that amateurs and broadcast listeners of France, England and northern Canada have reported picking up programs from this Philadelphia station time after time with extreme regularity.



Not the least of the features coming from WOO are the organ recitals. Aside from the fact that world-known artists are employed is the advantage of the organ itself. In addition to being one of the largest—if not the largest—it was built with the most exquisite care, which accounts for its marvelous tone quality. The photo above shows Miss Mary Vogt, one of the regular artists seated at the manual of the organ. Note the five key-boards.



The programs broadcast from WOO are excellent, partly on account of the fact that Robert E. Golden has a hand in the arrangement of them. The above photograph shows Mr. Golden playing a violin solo for the listeners to his station. When he is not engaged in playing for the studio he leads the Wanamaker Crystal Tea Room Orchestra.

Here (at the right) is shown another of Philadelphia's radio entertainers. It is the Strawbridge and Clothier's station WFI. The studio of the station is shown in the illustration. One of the most notable facts concerning this station is that it was constructed completely and entirely in the store where it is installed.

—Samuel Lovenstein, Reporter No. 4018.

# The Month's Radio Novelties

## A Radio Kiss—Record Making Station.

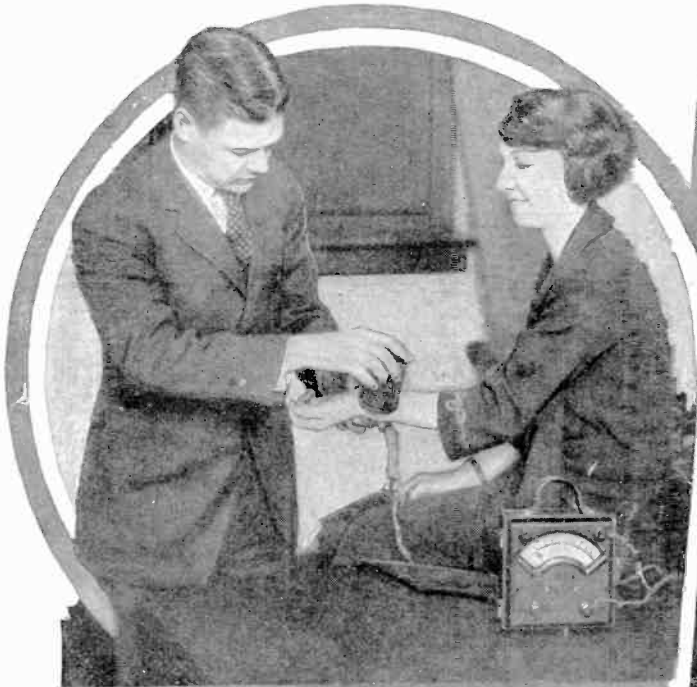

Another use has been found for the new, ultra sensitive Thomas microphone. It is to transmit the palpitations of the lovers' kiss. Above is shown the technical director of station KDKA attaching apparatus to the wrist of a young lady for demonstration.



Not only have the actual heart-throbs of lovers (see above) been broadcast to the cold, cruel world sitting at their receivers scouring the country for DX, but also the physicians have sought this universal method of telling the world how little Lady Ninotina does her stuff to tender, pure, defenseless little heart. They have shown (or rather made audible) the little vampire doing most terrible things to the pulse.

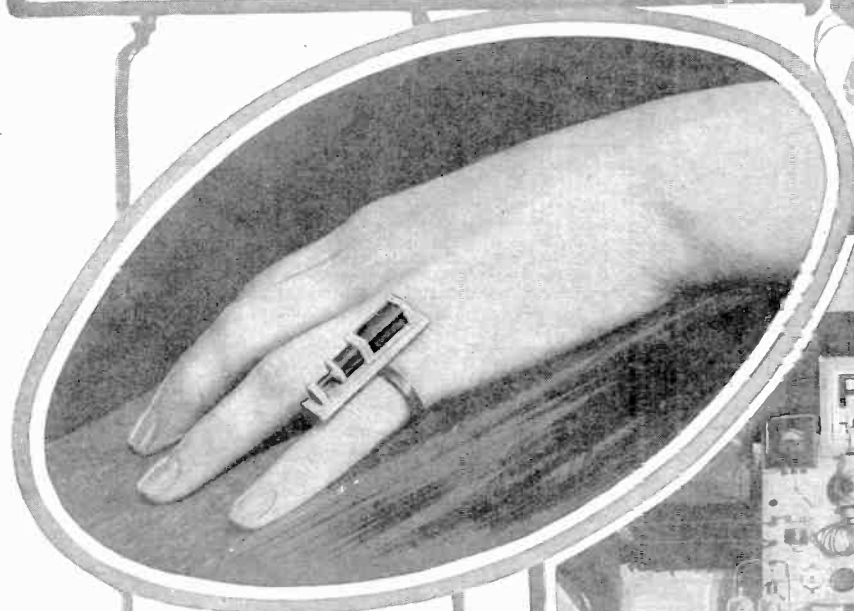

We have had honeycomb head-dress, telephone tiaras, peanut tube pendants and now come the jewelers and novelty mongers, still laying siege to our recalcitrant pennies through the medium of the radio emblems. Look at the illustration above and leave the extra quarters on the shelf by the gas-meter for the little woman or the best girl is sure to want the loose coupler ring. The ring itself is bona fide and will tune to a broad band of waves, permanent, marcel and otherwise.

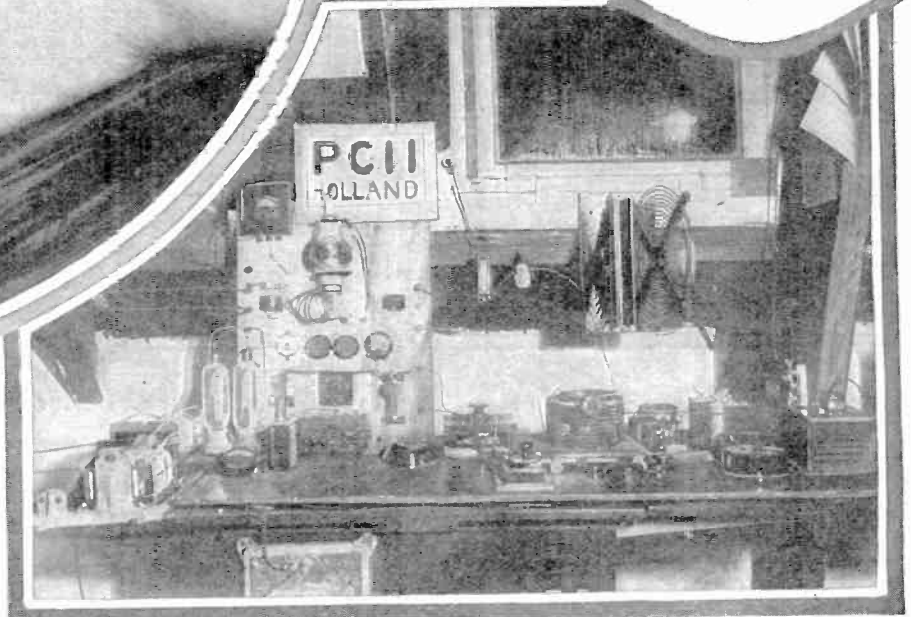

About a month ago several Chicago city editors cocked their heads and called a dubious reporter sending him out to the suburbs. It was a strange address to the reporter so sent. No movie actresses lived there and there were no convenient culverts about where dead bodies could be hidden. The address was a radio shack where a message from Holland had been received. Above is shown the station where the message started, sending it across the Atlantic in one jump. It is a record.

# Foreign Ideas in Radio Apparatus

Some Typical European Radio Manufacturer's Products

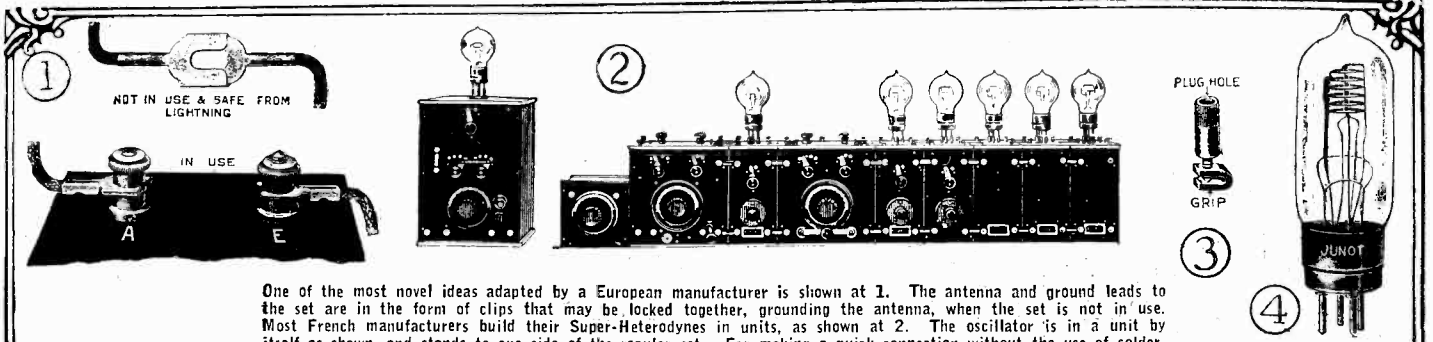

One of the most novel ideas adapted by a European manufacturer is shown at 1. The antenna and ground leads to the set are in the form of clips that may be locked together, grounding the antenna, when the set is not in use. Most French manufacturers build their Super-Heterodynes in units, as shown at 2. The oscillator is in a unit by itself as shown, and stands to one side of the regular set. For making a quick connection without the use of solder, we have a very novel idea illustrated at 3. The clip is made of spring metal and one connection is slipped through two holes, the other connection being passed through the crotch of the U formed by the spring metal. The spring clamps both connections tightly. At 4 we have a French spare filament vacuum tube. It might be well to note that all the vacuum tubes manufactured in the early days of radio had this spare filament characteristic. It was a great factor in saving since the life of the tube was practically doubled. When the first filament burned out it was only necessary to connect the second one in the circuit. We wonder why the French and English place the bulbs on top of the cabinet unprotected as is the case with the Super-Heterodyne shown above.

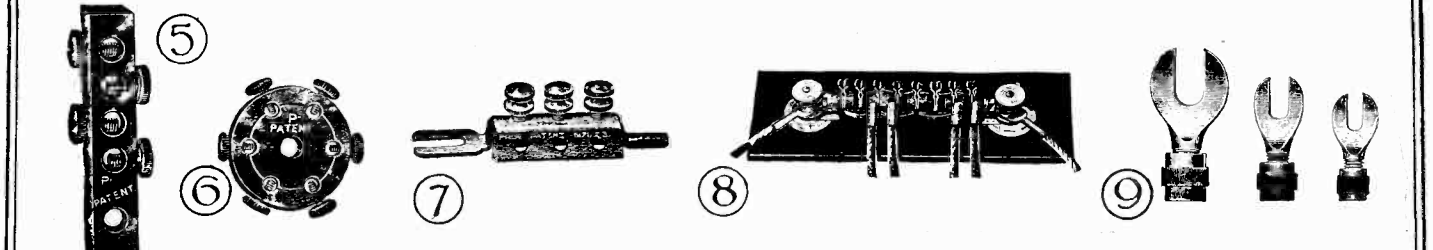

It seems that the Europeans are much stronger for unsoldered connections than are the Americans. In the above illustrations (from 5 to 9) we see a large number of connecting devices which are evident in every radio display throughout England and Continental countries. Also they are much more addicted to lugs than the American manufacturer. Representative adjuncts of this type are shown at 9. Possibly one reason for this fact is the comparatively exorbitant prices of radio apparatus as compared with the income of the experimenter in those countries. In experiments the same pieces must be used over and over again. Fig. 8 shows a multiphone-tip connection block.

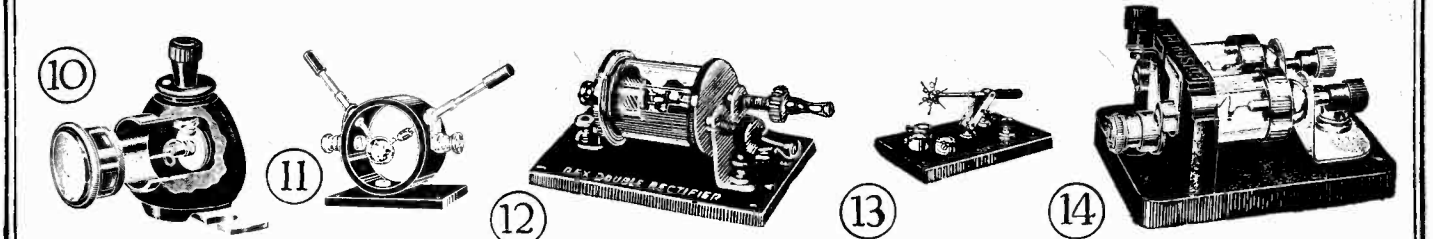

The popularity of crystal detectors may be judged by the number and variety of their design. Every radio shop will come near having dozens of them scattered about the shelves. Seemingly many more are sold there than here. The above illustrations from 10 to 14 show only a few of the varieties available. Note that in nearly all cases many crystals and cat-whiskers are available on the same stand.

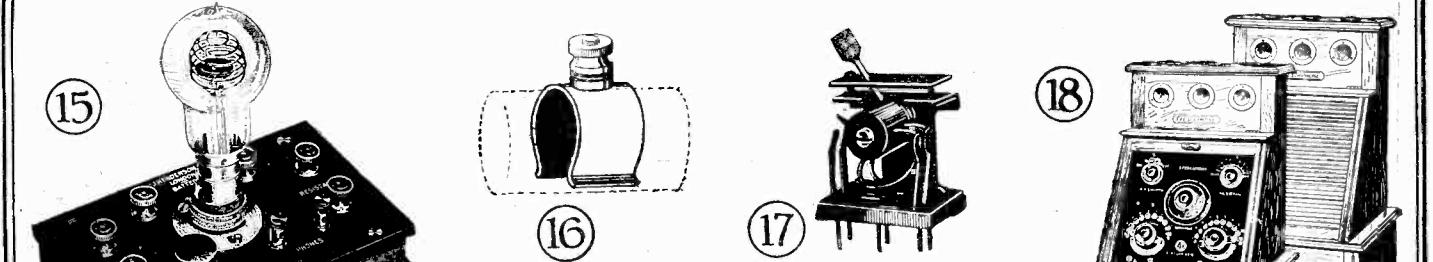

At 15 we have an instrument that the American manufacturers would do well to copy. It is called the Neon Unit and is used for making all sorts of radio measurements. With the assistance of outside shunts, inductances and capacities one may measure the capacity and natural period of the antenna, check the emitted wave of a station, determine the value of a coil or condenser—in fact, it is about the most valuable measuring instrument one may have about a radio station. It is enjoying great popularity with the European amateurs, at present. At 16 is a ground clamp which is installed by simply placing it over a pipe or rod. At 17 is a change-over switch with exceptionally low capacity. It is an exceptionally handy instrument for changing a double to single circuit tuner for quick shift. At 18 is given a recent and novel form of receiver cabinet in which the roll-top desk idea is adapted to the instrument. The roll cover is exceptionally easy to operate and gives the instruments perfect protection while they are not in use. This is another European idea that the American manufacturers and designers would do well to copy. It is our guess that it would be immediately accepted.

# The Ritz Super-Neutrodyne

By LEON L. ADELMAN

Here is the set you have long wished for; it combines remarkable distance getting ability together with perfect "squeal-less" reproduction.

Mr. Ritz is shown here at his eight tube set which comprises a great achievement in the art of radio reception. Besides the four tubes used as radio frequency amplifiers there is a detector tube which employs a plate variometer for regeneration in addition to a three tube push-pull power amplifier. The set uses 201-A tubes, while the amplifier unit operates very successfully with 216-A tubes. The sharpness in tuning is an outstanding feature, and it is indeed a great delight to operate such a set. Note carefully the clean cut appearance and efficiency of design.

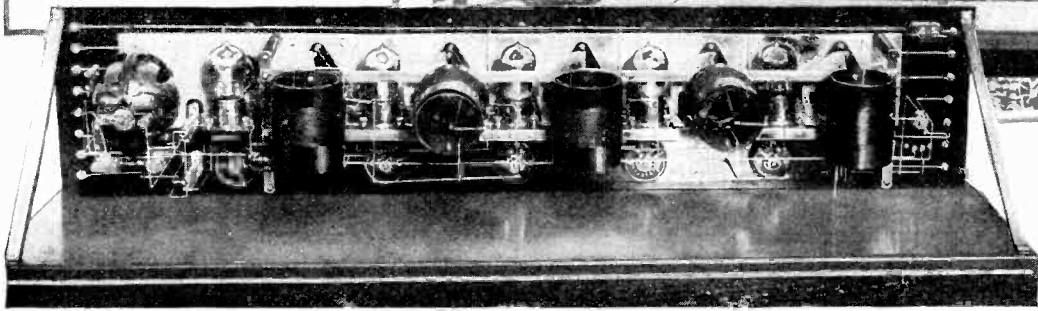
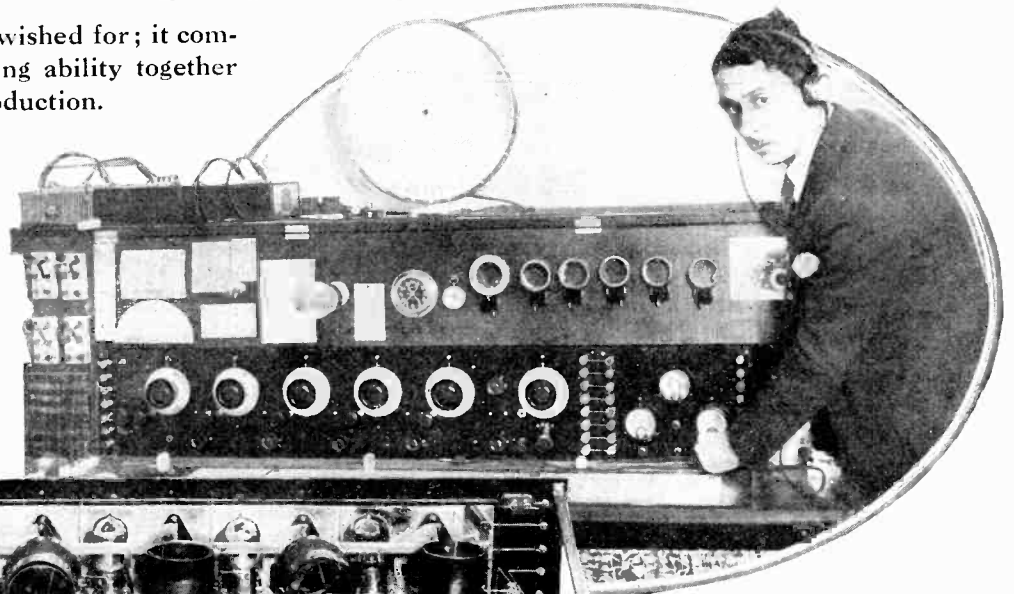

All the apparatus is mounted directly upon the panel, making it easily accessible for repairs. A shield is not necessary, but was incorporated to entirely remove any possibility of body capacity. By careful manipulation of the plate variometer and stabilizing potentiometers, which latter control two tubes at once, tremendous amplification with extremely distant reception becomes a possibility that was heretofore thought impractical.

**A**FTER eight months of hard and patient labor, Charles Caesar Ritz, prominent New York business man, has finally solved the problem of multi-staged, tuned, neutralized, radio-frequency amplification. His four-stage radio-frequency unit employs, practically, the Ferrand method of neutralization, adding special resistors and stabilizing controls. By a unique arrangement, the outfit can be used as a straight tuned radio-frequency set. There are four miniature single-pole switches placed in series with the neutralizing resistances and neutrodons, or neutralizing condensers.

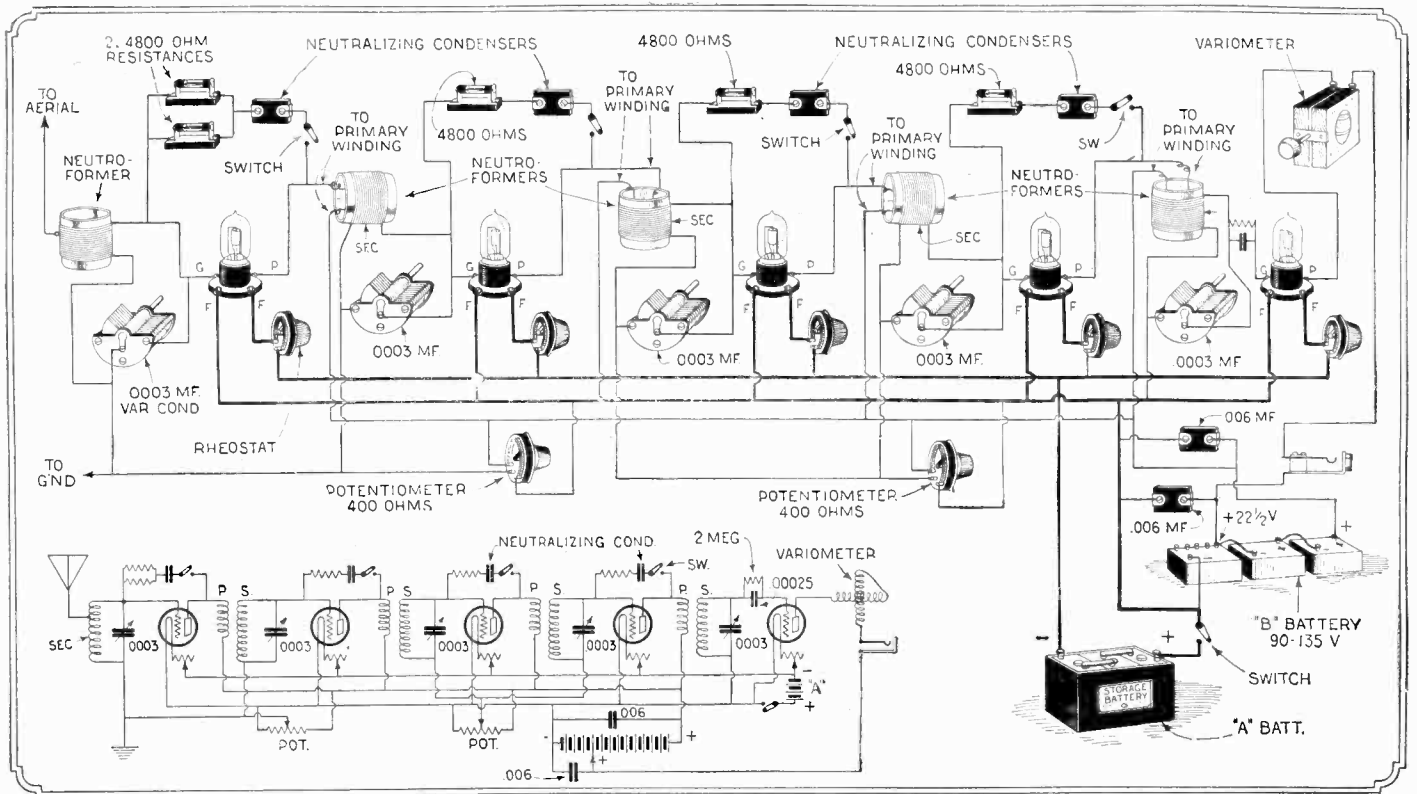

**T**HE majority of the radio receivers today employ radio frequency amplification. None of them use more than two stages, this being due to the trouble arising from self-oscillation which results in squealing. Only by the greatest amount of elaborate experiments was Mr. Ritz able to successfully use four stages. The set which he has evolved is very sharp in tuning and causes very little noise. Some remarkably distant stations have been heard, and those on the Pacific Coast come in with regularity as often as five nights a week. When the set is used as a straight tuned radio-

frequency receiver, very good results are obtained with a resultant slight diminution in volume. There is no appreciable difference in selectivity when used this way, although static is somewhat bothersome. The plate variometer readily offsets this, however, and causes sufficient regeneration of the incoming signal, so as to render the static negligible. All powerful local stations can be easily tuned out by a mere slight turn of any one dial. Instead of a three tube push-pull amplifier, a two stage audio-frequency amplifier is desirable, as the signal strength is more than necessary.

# A Selective 3 Tube Receiver

By W. L. PEARCE

Everyone is desirous of learning how best to employ three tubes in a receiving circuit. This hook-up, which consists of one stage tuned radio-frequency, one stage untuned radio-frequency amplification and detector, constitutes the best arrangement for a simple DX or long distance set. Photograph at the right shows the complete set, contained in a twenty-four by seven inch cabinet. The sketch immediately below shows how the tube sockets are supported on the sub-rack directly behind the panel.

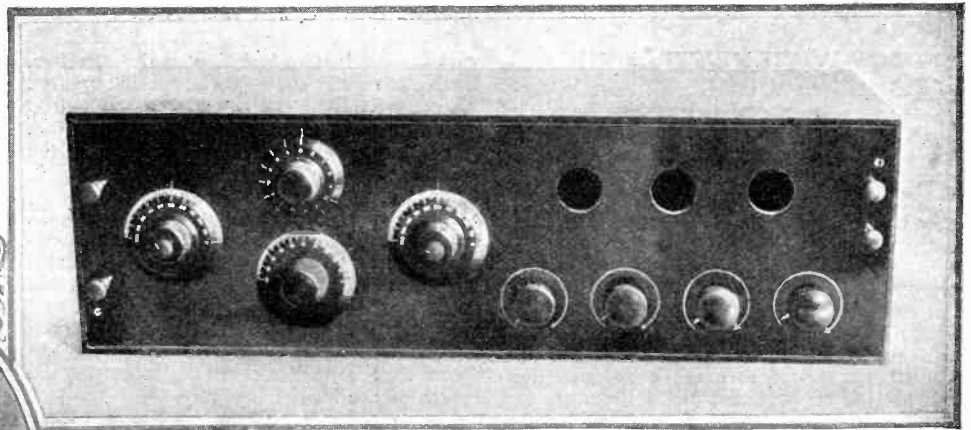

A glance behind the panel shows the layout of the instruments. A vario-coupler is used as the first radio-frequency transformer, and advantage is taken of the variable coupling. The second radio-frequency transformer can be of any make, while the third is a neutroformer.

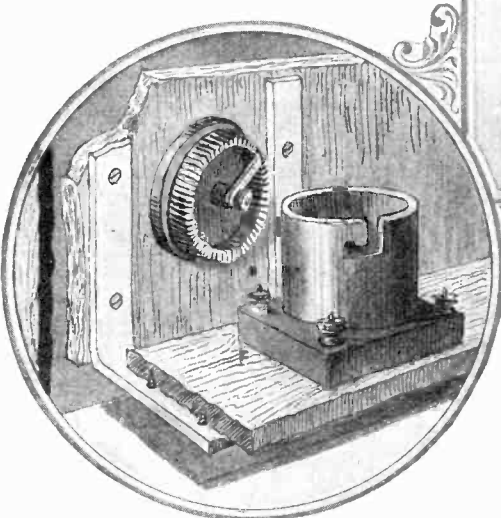
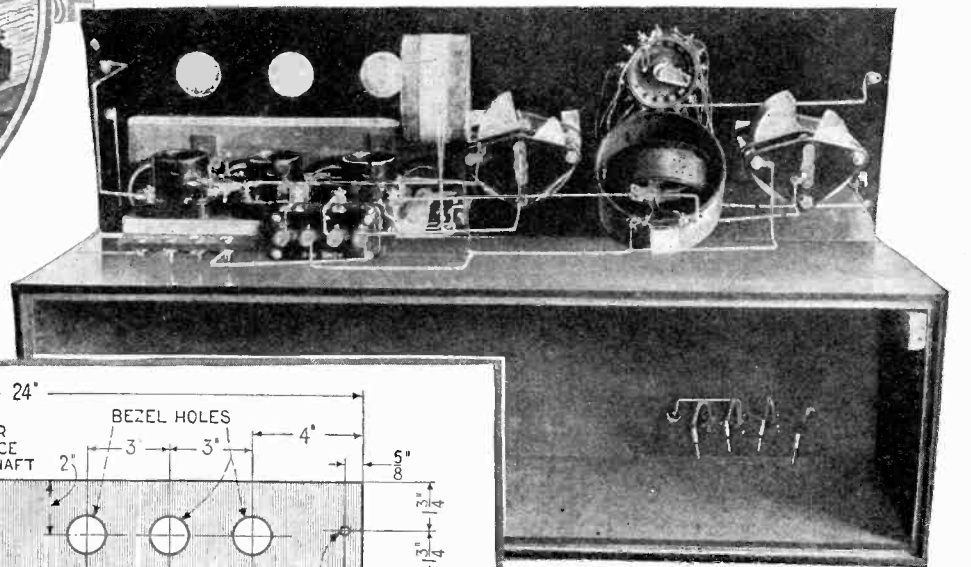

The panel lay-out calls for three bezel holes through which the tubes can readily be seen. The better panels are of bakelite, hard rubber, formica or glass.

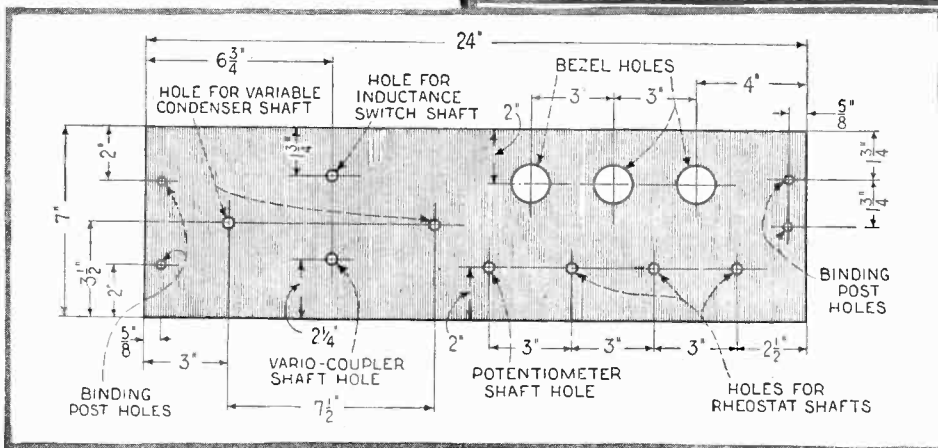

The diagram shows how the set is hooked up. A special arrangement for the battery terminal connections is shown in the photograph. Phone tips are soldered to short flexible leads, which are attached to the back of the cabinet, with binding posts. The phone tips are inserted in their respective jacks, which are racked on a small bakelite strip immediately behind the sockets. This receiver, due to the simplicity of its construction, does not cost very much to build, and offers a bountiful return in satisfactory operation. U. V.-199 tubes can be used instead of the ordinary 201-A's.

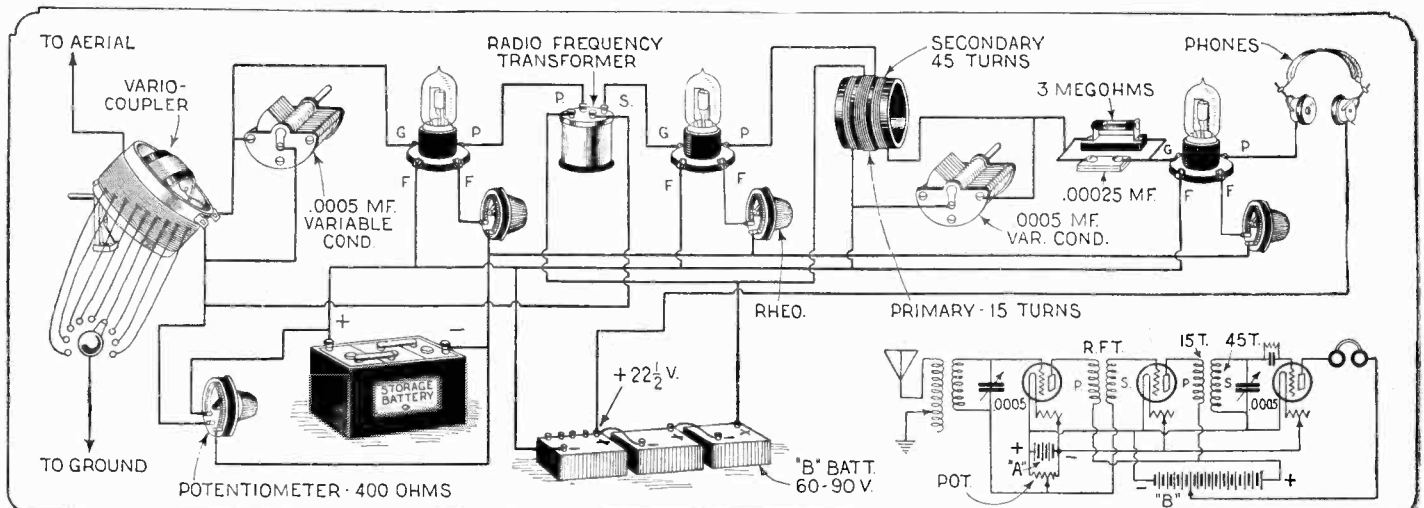

When tuning the set it is necessary to move both condensers at the same time, and this allows for direct calibration. Although a three megohm grid leak is shown in the diagram, a variable one is usually preferable. The primary inductance is varied by a 15 point

switch, and very fine tuning is accomplished. In its stead, however, a twenty-three plate variable condenser can satisfactorily be used. This set has received stations up to a distance of twenty-five hundred miles. Address the writer for any further data.

# Radio Oracle

In this Department we publish questions and answers which we feel are of interest to the novice and amateur. Letters addressed to this Department cannot be answered free. A charge of 25c. is made for all questions where a personal answer is desired.

## LOOP WITH NEUTRODYNE

(286) Morris V. Gordon, El Dorado, Arkansas, says he has a Neutrodyne receiver and would very much like to use it with a loop which he has recently purchased. He asks:

Q. 1. Will you kindly show diagram?

A. 1. A loop may be very successfully used with the Neutrodyne receiver and distances up to 1500 miles can be easily obtained. Although it is advisable to disconnect entirely the first radio frequency transformer and connect the loop directly to the first tube, this can be avoided by interposing a small fixed condenser in series with the antenna post as is shown in the diagram.

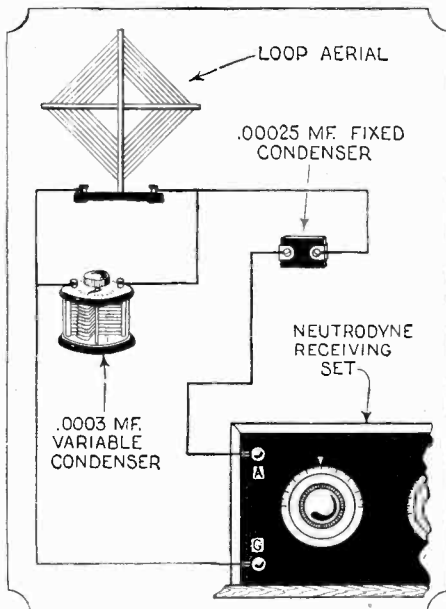

Q. 286. The interposition of a .00025 mf. condenser facilitates sharp tuning and offsets the necessity of changing the interior wiring of the Neutrodyne set for use with loop aerial.

## NEUTRODYNE HINTS

(287) Joseph F. Russo, New York City, N. Y., says he has assembled a Neutrodyne receiver using parts of a well known make and has heard other receivers, but his arouses his ire in causing him such exasperation as to give up in despair. He asks:

Q. 1. Can you suggest any help?

A. 1. The Neutrodyne, without doubt, is the real distance getter and when once adjusted, will cause no further trouble. The first place in which to look after trouble is the aerial circuit. Having ascertained that the primary winding is not broken, that all leads are carefully soldered, with a minimum of wire between terminals, the primary windings of the radio and audio frequency transformers are tested by the use of a single dry cell and a pair of phones. Similarly, all secondary windings are tested, and then the fixed condensers. These in many cases, especially when they are shunted across the high voltage terminals, will break down and make a short circuit, doing material damage.

Blow all dust from off the plates of the

variable condensers and tighten the bearings, having carefully centered the movable plates. This is vital, as the loose bearing contact is a very high resistance connection in a R.F. circuit. Under no circumstances should the bearings become so loose that it is possible to actually spin the dials around.

Many times the Neutroformers or R. F. amplifying transformers are too close together. This causes interaction with maximum tendency for making the R. F. tubes oscillate which of course is undesirable. At 54.7 degrees from the vertical the coils should be at least  $1\frac{1}{2}$  inches apart, and no more than 5 inches, as this increases the length of the leads materially.

Very often, too, it happens that a poorly constructed tube is responsible for the inferior results obtained with the Neutrodyne. A poor detector tube is the worst of all the poor tubes on any set, let alone the Neutrodyne.

If after trying vainly to neutralize a set, a .006 by-pass condenser is placed across the secondary of the audio frequency transformer, and a 200 ohm potentiometer placed in series with the plate supply of the "B" battery, the negative pole of both "A" and "B" batteries grounded, the set will in the majority of cases be completely neutralized. In this way 135 volts instead of the usual 90 can satisfactorily be used on the amplifier tubes with the resultant increase in volume.

## NECESSITY OF GRID LEAK

(288) William J. Williams, Omaha, Nebraska, says he has tried many circuits and has found that in some he could entirely eliminate the grid leak without undue loss in volume of an incoming signal.

Q. 1. Can you explain this?

A. 1. While it is true that many circuits will work satisfactorily without a grid leak, yet there are many more that will work to better advantage with one. During the process of reception, negative charges of electricity pile up upon the grid due to the action of the grid condenser. If a means for returning these superfluous and excessive negative charges to the filament is used, through the employment of a suitable grid leak, signals will be reproduced with fidelity. However, if a grid leak has too high a resistance, these charges escape too slowly and naturally the incoming signal becomes distorted. If the grid-leak resistance is too low, the incoming signal is short circuited and a large amount of the energy is wasted. For the ordinary detector tube, 1 to 3 megohms should be experimented with, in order to find a suitable value for the tube. As a detector tube is generally a soft tube or in other words has a gaseous content, it sometimes is not necessary to employ a grid leak. This is because the negative charges are carried away by the ionized hot gases within the tube. Again in the employment of a hard tube for detection, the gas content being relatively much lower, the negative charges, if no grid leak is employed, actually become sufficient to paralyze the rectifying action of a tube and no signals will be heard. In this connection especially when a high voltage "B" battery is used, it is best to use a grid leak.

## AUDIO FREQUENCY AMPLIFIER

(289) Frank Tarleau, Frankfort, New York, asks:

Q. 1. Kindly give me full particulars for making a two stage audio frequency amplifier and what is the advantage of using high ratio transformers?

A. 1. The hook-up given below depicts clearly how to connect the various instruments in a two stage audio frequency amplifier unit. The "C" battery is introduced in the grid circuit and its function is to lessen the plate current slightly, thus giving clearer reproduction. It is absolutely unnecessary to use high ratio transformers inasmuch as distortion begins to occur in

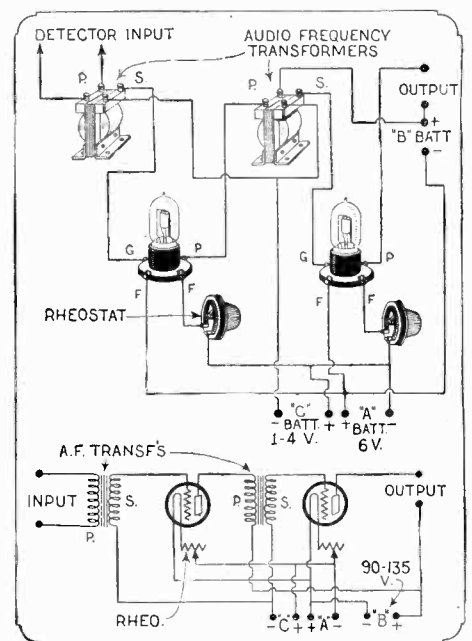

Q. 289. An efficient two stage audio frequency amplifier whose first name is "Clarity" is shown here.

transformers having a higher ratio than 1 to 1. The average all around transformer which is best adapted for use in an audio frequency amplifier is one having a  $3\frac{1}{2}$  to 1 ratio.

By carefully adjusting the grid biasing battery, amplification without distortion can be accomplished when using higher ratio transformers, although this is not advisable inasmuch as a "C" battery will tend to cut down the volume.

## TUBE BASE CEMENT

(290) Alexander J. Wilcox, Hollywood, Calif., says that his tube seems to have become loose from its base. He asks:

Q. 1. Can you please tell me how to fasten it again?

A. 1. A ready repair for such a state of affairs would be to melt ordinary sealing wax around the top of the base and let it become hardened. Of course, if you desire a more finished appearance, ordinary marble dust mixed with shellac will serve as a very durable cement for your purpose. Be sure that you do not twist the tube around so as to short-circuit the connections in the base.

## WANTED!!! RADIO ARTICLES

WE want descriptions of new radio ideas which you have worked out in practice. Take photographs of the important parts and make pencil or pen and ink sketches of the hook-ups or mechanical details, et cetera. We are particularly

desirous of obtaining new hook-ups and descriptions of single tube sets, reflex and other types which have proven satisfactory. We like articles on new single tube receptors. We will pay good prices for your ideas.

—Editor.

**STABILIZING METHODS**

(291) H. K. Wilder, East Pittsburgh, Pa., asks:

Q. 1. Can you kindly tell me of several different ways in which I can improve the tonal quality of my three tube radio set?

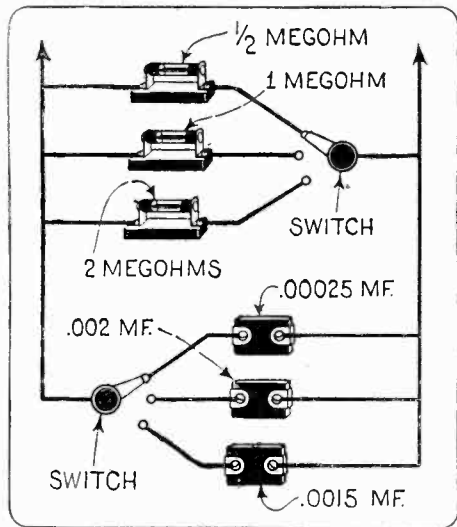

Q. 291. By employing various values of grid condensers and leaks the best size for the different stages in the life of a vacuum tube can be readily ascertained.

A. 1. The quality of reproduction can be greatly improved by the addition of by-pass condensers, stabilizing potentiometers and a variable grid leak and condenser. The diagrams depicted show clearly what changes to make in your receiving set. Always be sure that only a minimum of moisture is able to get into the receiving set, because moisture not only lowers the efficiency of the apparatus employed, but tends to accelerate corrosion of contacts and short-circuit all the insulating material.

**CIRCUIT EMPLOYING A LOUD SPEAKER**

(292) John Moore, Summerville, N. J., says he has built a set using two tubes and

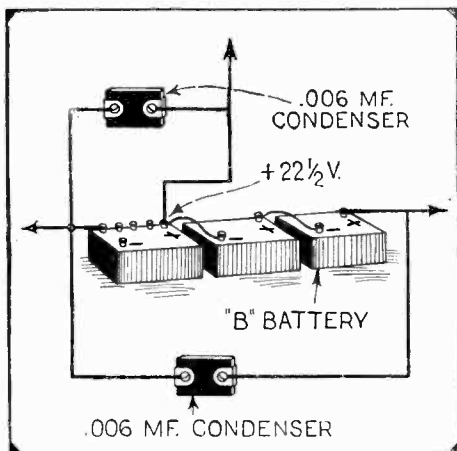

Q. 291. The "B" battery should be shunted with small fixed condensers which by-pass the radio frequency currents.

a crystal and fails to get results on his loud speaker with it, although he hears many stations distinctly with the phones. He asks:

Q. 1. Can you help me?  
A. 1. According to your diagram, the circuit which you employ is a two stage radio frequency amplifier and crystal detector frequency circuit. As is well known, radio frequency amplification affords relatively no marked increase in volume, but does tend to give a circuit selectivity to a much greater degree than could otherwise be obtained. Would very much suggest that you change your circuit to one stage radio frequency amplification, crystal detector and one stage audio frequency. The same "B" battery can be used for the operation of both tubes.

**NEUTROFORMER DATA**

(293) James Rubbenrout, Atlanta, Ga., says that as a last resort he is writing to us for all information concerning data pertaining to the winding of neutroformer coils. It seems that all those parties whom he has asked disagree as to the number of turns that should be employed in the primary winding. He asks:

Q. 1. I want reception from 200 to 600 meters, that is to cover all broadcasting wave-lengths. How can I accomplish this?

A. 1. For the most efficient neutroformer a self-supporting coil, wound with a large size wire such as No. 12, silver plated to reduce skin effect and which winding is staggered, similar to the winding of a low loss coil, should be used. However, as there are too many technicalities to be overcome in the construction of such a coil, the nearest approximation to it can be obtained by using a secondary tube which measures three inches in diameter and whose winding will consist of 65 turns of No. 22 double cotton covered pure copper wire. The primary will be 2 3/4 inches in diameter and should be wound at one end with 15 turns of No. 18 double cotton covered wire. Both tubes should be 3 1/2 inches long and of a non-porous, non-hygroscopic, non-absorptive insulating material such as bakelite or a very good grade of formica. If at all necessary, the coil should be impregnated with collodion. The secondary has a tap taken off at the 15th turn. This tap connects with the neutralizing condenser.

**CRYSTALS AND CONTACTS**

(294) Willis C. Webb, Muskegon, Mich., asks:

Q. 1. Can you give me some information on the use of galena and silicon as rectifying elements in a crystal detector? Must the surface of the crystal be smooth?

A. 1. The most sensitive crystal of those mentioned to use in a receiving set is galena, which works best with a very light phosphor bronze or gold cat whisker. Silicon may also be used, but we advise you to procure a piece of fused silicon, and use it with a brass point contact, using quite heavy pressure. It really makes very little difference whether the surface of the crystal be smooth or not, but galena generally comes in a cubic crystalline form with very smooth faces.

**CONTROLLING OSCILLATION**

(295) W. P. Auchey, Pasadena, Calif., says that his three coil honeycomb set oscillates very freely causing unearthly squeals. He asks:

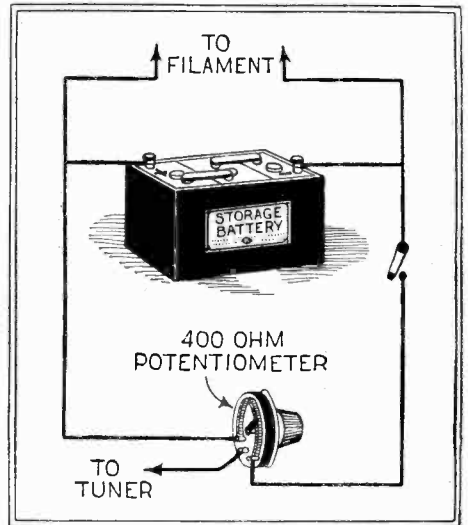

Q. 291. If a potentiometer is connected across the "A" battery, much finer control in tuning can be had.

Q. 1. How can I remedy this?  
A. 1. First cut down your "B" battery voltage, if higher than the normal rating required by both detector and amplifier tubes. Turn the filaments down if too brightly lighted. If you have a filament current ammeter, check up to see that you are not overloading your tubes.

Next, loosen tickler feed-back coupling until the set is just on the verge of breaking into oscillation. If squealing still occurs, change value of grid leak.

A .00025 mf. fixed grid condenser can be used for practically all tubes and when shunted with a leak of from 1/4 to 2 megohms resistance will give the best results. It may be that the honeycomb coil used as the tickler is too large, having too much inductance. Try a smaller tickler coil.

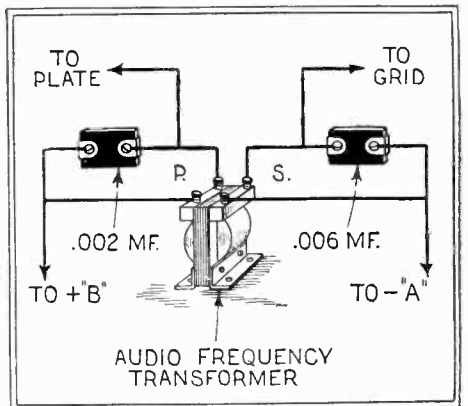

Q. 291. The A.F. transformers should have by-pass R.F. condensers across their terminals. The use of the lower ratio transformers is advised.

**A SENSATIONAL RADIO INVENTION**

The crystal now replaces the vacuum tube. A full description of this startling achievement is featured in the September issue of RADIO NEWS now on all newsstands.

Mr. O. V. Lossev, a young Russian engineer, has discovered a way to make a crystal oscillate. Not only is it possible to receive

over long distances with a crystal, but it is also possible to send or transmit with this new CRYSTODYNE PRINCIPLE. The new CRYSTODYNE does everything that the vacuum tube does. One of the greatest discoveries of radio in the past twenty years. Do not fail to read all about it.

**INTERESTING ARTICLES APPEARING IN SEPTEMBER RADIO NEWS**

The Crystodyne Principle.

A. C. Applied to Receiving Sets.

Neutrodyne Receivers.

By Florian J. Fox.  
By A. L. Groves.

Reflex Radio Receivers in Theory and Practice.

The Use of Iron in Transformers.

By John Scott-Taggart.  
By Sir Oliver Lodge.

Six Tube Receiver of Advanced Design.

More Solodyne Circuits.

By The Technical Staff.

By A. D. Cowper.



# LATEST PATENTS

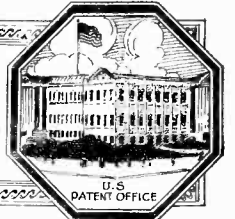

## Oil Well Operation

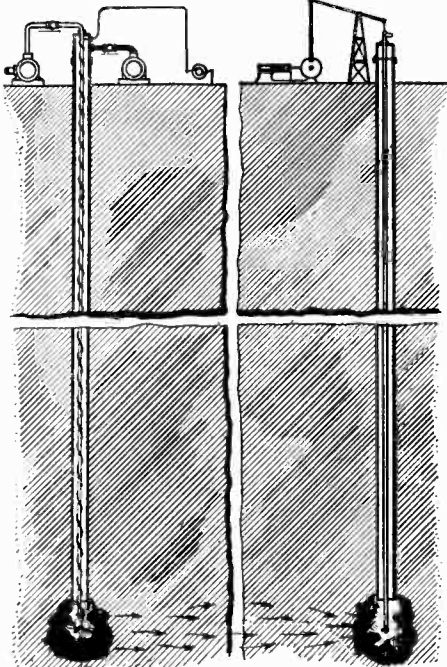

1,473,348, issued to Frank A. Howard. Air is pumped into a dry well casing. Thereafter, gas is pumped into the well to form a combustible mixture. This is ignited and the pressure of the gases force oil from the shale into surrounding dead wells, which oil is then pumped up.

## Hair Clipper

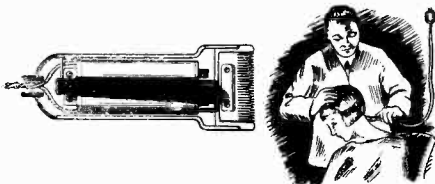

1,471,536, issued to Leo J. Wahl. The clipper indicated above is of the vibrating type and operates on alternating current circuits. The armature moves toward and away from the axes of the electro-magnetic coils. One of the clipper blades is attached to the moving armature, the other is stationary.

## Mechanical Fountain

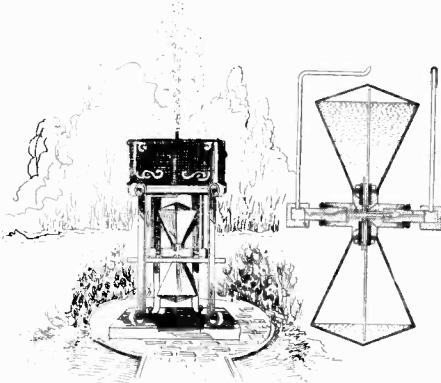

1,490,833, issued to William F. Kling. Two cone shape tanks are mounted on an axle fitted with pipes as indicated above. When the tanks are in the position shown, water will flow into the lower tank, decrease the air space and cause the fountain to bubble. When the fountain stops the tanks are reversed and operation begins anew.

## Razor Strop



1,485,350, issued to John W. Shepard. This razor strop is supported by two retaining cuplike members, one engaged by the finger and another by the thumb and held in this position during the stropping operation.

## Comb Combination

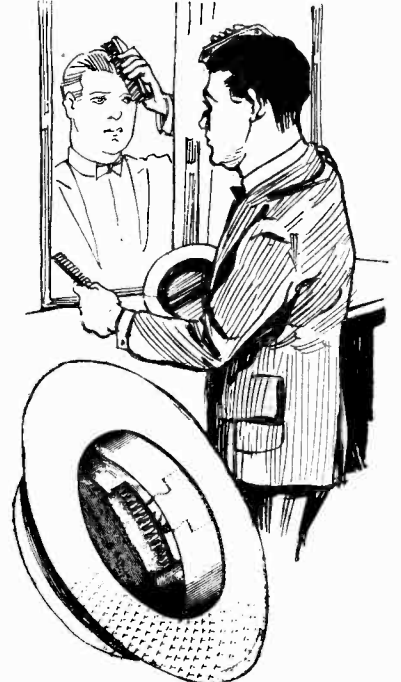

1,497,524, issued to Leo McSweeney and Arthur Wilson. The comb in this device is slipped into the handle of the brush. The whole is then held in place in a hat and is available for instant use. The holder is designed for both soft and hard hats.

## WANTED

ARTICLES pertaining to automobiles such as handy kinks, roadside repairs and anything of interest to the man who drives a car. \$50.00 in prizes every month are offered by MOTOR CAMPER AND TOURIST for such articles. Get a copy at your newsstand and see what is wanted. If your newsdealer cannot supply you send for free sample copy to:

MOTOR CAMPER & TOURIST  
53 Park Place,  
New York City.

## Leveling Device



1,488,749, issued to Jacob Franz. The system described in this invention is not new, this leveling device having been used years ago in China and other countries. The inventor improves upon the idea by adding a valve to the top of each of the glass tubes. A flexible tube filled with a liquid completes the arrangement.

## Moth Ball Holder

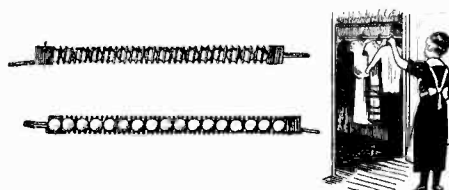

1,484,510, issued to Robert J. Lewers. A long coiled spring wire forming a clothes hanger, contains moth balls. This may be used for hanging garments upon or it may be placed along the seams of the door where its action is very effective. It can easily be replenished.

## Advertising Idea

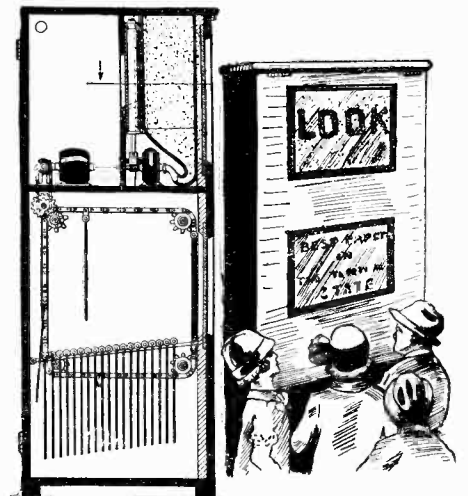

1,475,540, issued to Henry M. Cheek. A blower in the bottom of the upper half of the cabinet causes confetti or bran to fly around and form letters due to the fact that the cabinet is air-tight except for the cut-outs of the letters, which are covered with gauze.

## Rotary Tooth Brush

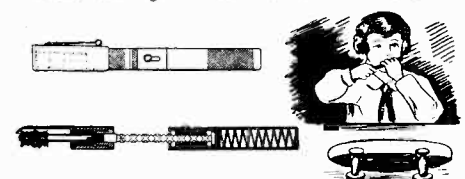

1,481,891, issued to James R. Cruikshank. The rotary tooth brush illustrated above is made in the form of a fountain pen. By working the handle back and forth the brush rotates rapidly and in this manner cleanses the teeth thoroughly.



# Scientific Humor

## PARADOXICAL

PROFESSOR: "Can you cite an instance where heat produces cold?"

FLIP STUDENT: "When the critics roast a play it becomes a frost."—*Jas. J. O'Connell.*

## WE'RE DUSTLESS

"That professor has an odd name for the money he makes from lecturing on astronomy."

"What does he call it?"  
"Star dust."—*Les Van Every.*



## THE LOST CHORD

TEACHER: "Name an important bodily organ and part of it."

LOTTIE: "The throat organ and its windpipe."—*Herbert F. Bechtold.*

## WHAT DID TENNESSEE SEE?

They were talking of the marvels of wireless telephony and a conversation between Rome and London was mentioned. "Ah that's nothing," replied Braggo, "I know a man who blew a bugle in Pittsburg and went to Long Island and saw the Sound."—*H. Rowe, Jr.*

## BUGHOUSE

"Ma, does a bear pass through the larva stage too?"

"Nonsense, child."

"But what's a bugbear?"—*Herbert F. Bechtold.*

## FIRED

"Our hired man is like static electricity."

"How is that?"

"He is always at rest until he is discharged."—*Reporter No. 6042.*



## WHERE ENDS MEET

"My Math. Prof. is surely absent-minded. Why, I've seen him time and again trying to strike a match on the wrong end."

"Is that how he wore all his hair

off?"—*Campbell Search.*

## A "COLT" IN THE CHEST

A young Dutch singer had an engagement with a radio broadcasting station. The night of the program found him slightly hoarse, and his Dutch manager undertook to explain his absence to the radio public thus: "Ladees and chentlemen Mr. Blank wishes me to tell you that this evening he is a little 'hoarse'". Fearing the people would not understand he continued:—"Vat I meant to say is that Mr. Blank is a little horse, he has a little colt you see."—*Raymond Fullerton.*

## NOT ACCORDING TO DARWIN

"My ancestors came over in the Mayflower."

"That's nothing, my father descended from an airplane."—*H. B. Dahl.*

## RIGHT

What musical instrument has been produced by Radio?—The Lyre.—*E. O. McCoy.*

## First Prize \$3.00



## SHADES OF ARCHIMEDES!

PHYSICS TEACHER: "Now James, what did Archimedes say when he found his bath was overflowing?"

JAMES: "Eureka, I have found it."  
TEACHER: "And what did he find?"  
JAMES: "Er—he must have found out how to stop the water."—*James Mersand.*

## HE'LL BE DEAD SOON

LONG-WINDED PROF. (to class in astronomy):—"Now, young men, as we take this trip through the ether which lies beyond the atmosphere of our earth, I shall show you many wonders of interstellar space—"

(Follows, a long period, broken at length by the snoring of a student on the back seat).

WE receive daily from one to two hundred contributions to this department. Of these only one or two are available. We desire to publish only scientific humor and all contributions should be original if possible. Do not copy jokes from old books or other publications as they have little or no chance here. By scientific humor we mean only such jokes as contain something of a scientific nature. Note our prize winners. Write each joke on a separate sheet and sign your name and address to it. Write only on one side of sheet. We cannot return unaccepted jokes. Please do not enclose return postage.

All jokes published here are paid for at the rate of one dollar each, besides the first prize of three dollars for the best jokes submitted each month. In the event that two people send in the same joke so as to "tie" for the prize, then the sum of three dollars in cash will be paid to each one.

LONG-WINDED PROF.: "What is the matter with the youth? Has he gone asleep or is he ill?"

ATTENTIVE STUDENT: "Don't know, Prof. He was all right before we entered the ether, but we've stayed so long I'm afraid he's chloroformed!"—*John R. Malloy, Reporter No. 12257.*

## JUST DUMB

ASTRONOMY STUDENT: "That star above us is ten times as large as the earth."

NEW STUDENT: "Then why doesn't it keep the rain off the earth?"—*H. B. Dahl.*

## HENS DON'T LAY EGG-PLANTS EITHER

LADY: "Why didn't you plant those bulbs like I told you to?"

RASTUS: "De sockets was missin', ma'am."—*Herbert F. Bechtold.*



## MARATHON GARAGE

PESSIMIST: "Now it's death by carbon monoxide."

HISTORIAN: "Probably, that famous Greek runner died of exhaust, you know."—*Herbert F. Bechtold.*

## THE PHONE "TOLLED"

VOICE ON THE WIRE: "Do you mind holding the wire a minute?"

OTHER VOICE: "Certainly not. What I object to is holding the receiver."—*Jas J. O'Connell.*

## SHE WAS A CHICKEN

SHE: "What is home without mother?"

HE: "An incubator, I suppose."—*Ned Guffey, Reporter No. 6042.*



## THE RAINBOW RACE

The negro is born black, therefore he is not colored. Being human he sometimes feels blue, becomes green with envy or flies into a purple rage and sees red. Even in the pink of condition he may get white with fear and show a yellow streak.—*Joseph M. Straughan.*

## UNDAMPED IN THE MOUNTAINS

RADIO FANS "Now that they are broadcasting the breakers on the shore, what kind of waves would you say we were hearing anyway?"

RADIO NUT: "Well, I suppose they ought to be 'damp' ones, don't you think?"—*Winthrop M. Leeds, Reporter No. 6625.*

## ZOO LOGICAL

Women make monkeys of men.—*H. B. Dahl.*

## THEN SHE GOT DAD'S FOOT

DADDY (winding up a stern rebuke): "Now do you understand what I say?"

SMALL DAUGHTER (unimpressed): "Will you broadcast it again, Daddy? I haven't quite got your wavelength."—*T. B. Marsden, Jr.*



## AND CHINA ON BAMBOO SPREADERS

JOE: "I just got the 'Lost Chord' over my 'stranded' aerial yesterday."

BLOW: "That's nothing. I got the bedtime stories over my bedspring aerial."—*Maurice Bergar.*

## A GREEN LITTLE VERSE

A green little chemist on a fine summer day  
Some chemicals mixed in a green little way.  
The green little grasses now tenderly wave  
O'er the green little chemist's green little grave.  
—*H. B. Dahl.*

## A MUD HEN

YOUNG LADY: "What do you think of mud as a beautifier?"

BEAUTY SPECIALIST: "Well, it hasn't done much for the turtle."



# THE ORACLE



The "Oracle" is for the sole benefit of all scientific students. Questions will be answered here for the benefit of all but only matter of sufficient interest will be published. Rules under which questions will be answered:

1. Only three questions can be submitted to be answered.
2. Only one side of sheet to be written on; matter must be typewritten or else written in ink, no penciled matter considered.

3. Sketches, diagrams, etc., must be on separate sheets. Questions addressed to this department cannot be answered by mail free-of charge.

4. If a quick answer is desired by mail, a nominal charge of 25 cents is made for each question. If the questions entail considerable research work or intricate calculations a special rate will be charged. Correspondents will be informed as to the fee before such questions are answered.

## POLARIZED LIGHT

(1729) Rudolph P. Goodrich, Ferndale, New York, wants to know:

Q. 1. What is polarized light and how can I produce it?

A. 1. It is generally agreed that in light waves the vibrations are wholly at right angles to the direction of the ray. In homogeneous light or light of one wave-length the vibrations are conceded either to be in all planes of the circle,

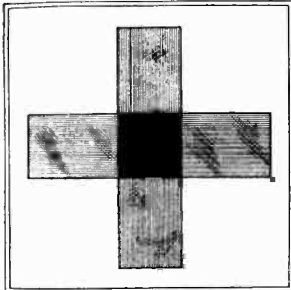

Two crystals of tourmaline, having their axes perpendicular to each other, afford complete stoppage of light. Rotating one until both are parallel gradually permits light to filter through. A number of mystifying experiments can be made with polarized light.

some of the ellipse or in a single plane, but in white light, they are doubtless very complicated and irregular. If a plate of tourmaline crystal is placed in front of a beam of light, the beam will be passed through it and be affected so that the light emitted will consist of vibrations all taking place in some one direction perpendicular to the ray. A beam of light having this characteristic is said to be polarized. If another plate of translucent tourmaline is placed with its axis at right angles to the first one and directly behind it, all light will be completely cut off. The first plate of tourmaline is called the polarizer, the second plate, the analyzer.

## TRANSFERRING STENCILS

(1730) C. H. Chittenden, Ames, Iowa, would like to know:

Q. 1. How can I transfer fancy work stencils so that the design will be transferred red?

A. 1. Your question is rather difficult to answer offhand as we have no data concerning the same. However, you may try adding ordinary glue to a solution of warm water and soaking your stencil in that, after which it may be transferred. However, we will not guarantee results. We have tried to get information on this, but evidently there is none available.

## FIXATION OF NITROGEN

(1731) Lawrence A. Stover, Vickery, Texas, asks:

Q. 1. Are the Haber or Bjornstrom processes used in this country and what information have you pertaining thereto?

A. 1. We believe that the Haber process is being used in the Muscle Shoals plant operated by the Government. As regards the Bjornstrom process, it is an entirely Norwegian undertaking and we do not believe that the process is undertaken in this country. You may write to De Nemours DuPont & Co., Inc., 120 Broadway, New York City, for more particulars, also to the Superintendent of Documents, Government Printing Office Washington, D. C., and ask him for the latest publication on synthetic nitrates and fixation of nitrogen.

## Power Without Wires

Is it possible to transmit power at a distance? It is! This is not a theory but a number of very interesting experiments over short distances are described in the September issue of PRACTICAL ELECTRICS by Mr. Esten Moen.

Anyone with existing apparatus is able to light small lamps over short distances. Every reader of SCIENCE & INVENTION will be interested in this article. Do not fail to get this important issue.

## OTHER ARTICLES IN SEPTEMBER PRACTICAL ELECTRICS

- French Million Volt Laboratory.
- The Most Amazing Stuff on Earth. By Esten Moen.
- Testing Metals with Roentgen Rays. By Dr. Franz Fuchs.
- Floodlighting Madison Square Garden.
- Solar Thermo-Electric Battery.

## WEATHER INDICATOR

(1732) Howard E. Bowen, Baltimore, Md., wants to know:

Q. 1. How can I make a rain indicator to turn pink for rain and blue for fair weather?

A. 1. If you will mix gelatine with water and then pour the solution on the blotting paper, the same solution being first heated but not brought to a boil, and then after it is tacky enough, sprinkle your cobalt chloride upon the paper or blotter, you will obtain much better results than with any other method. You must be sure that you have cobalt chloride, however. There are very few other salts that will work.

## OUR \$12,000 PRIZE CONTEST

It will be noted from recent issues and the present one that our prize contest has been a whale of a success. Over \$1,000 has been paid out this month for worth while contributions to SCIENCE AND INVENTION, either in pictures, suggestions, ideas or articles. We now have on our staff, close to 14,000 correspondent reporters who are scouting the world for

new material that can be written up for SCIENCE AND INVENTION. And the formula is simple—just keep your eyes open. Even if you were totally deaf or blind, you could still win a prize by simply using your head and sending us ideas of a scientific nature, or of a nature directly or indirectly attached to new inventions.

## ARTICLES FOR OCTOBER SCIENCE AND INVENTION

- How to Judge Cotton, Silk and Linen. By Ismar Ginsberg, B.Sc., Chem. Eng.
- New Convertible House with Revolving Floor. By Dr. Albert Neuburger.
- A New Explanation of Saturn's Rings.
- Magellanic Cloud Stars. By Charles T. Dahama.

- Salvaging Sunken Ships—Things You Ought to Know. By H. Winfield Secor, E. E.
- Molten Metal Rockets to Combat War-time Aircraft.
- The Future and Science—What Can We Expect?

- Dirigible Used to Locate Valuable Ore Deposits.
- How to Build a Model Steam Boat.
- Unique Clocks.
- The Earliest American Patents.
- What Would Happen if the Earth Speeded Up? The Science of a "Shower of Fish."

## FREE INFORMATION

If you want additional information concerning any of the subjects illustrated and described in this number of SCIENCE AND INVENTION we shall be glad to give you other data we have at our command. To make this work as easy as possible for our editors, please be brief. Write only on one side of the paper and state exactly in a few words just what it is you desire further information on. We have the original manuscripts and drawings of many of these articles in our files and can furnish much additional data in most cases. Please do not fail to send stamped and self-addressed envelope. Make all questions concise and specific.

Address all inquiries of this nature to INFORMATION EDITOR c/o Science and Invention, 53 Park Place, New York City.

## CAPILLARY ELECTROMETER

(1733) Jesse Hiller, Jersey City, New Jersey, asks:

Q. 1. What is the simplest means of determining the direction of an electric current?

A. 1. There are several positive methods of determining the direction of an electric current. One very good method is to put some dilute acid into a glass tube, corking it at the ends and inserting wire at each end. A drop of mercury

Dilute sulphuric acid and a drop of mercury placed in a glass tube composes a capillary electro-meter. This can be used to measure potentials as low as one volt. The higher the potential, the faster the mercury travels towards the negative pole.

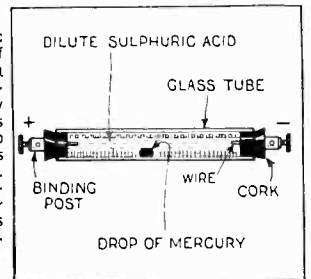

is placed in the center and the current turned on. The mercury will travel towards the negative electrode. The reason for this is that the surface tension where the current passes from the acid to the mercury is increased and where it passes from the mercury to the acid is decreased,—hence the motion of the mercury. A number of interesting experiments can be tried with such a simple little piece of apparatus.

## CHLORINE

(1734) Maxwell Strong, Albion, Mich., wants to know:

Q. 1. Since chlorine is a poisonous gas, what uses does it find in our everyday life?

A. 1. Chlorine, a greenish yellow gas with a very disagreeable odor, is used mainly in the manufacture of bleaching powder. Being a very active element, it decomposes many compounds, to form more stable ones.

Ordinary salt is composed of sodium and chlorine, yet it is beneficial instead of being harmful to ourselves.

As a disinfectant, chlorine is one of the most powerful. In the purification of water it displaces the oxygen which in this free stage destroys all bacteria. As little as 17 parts of chlorine as a cure for colds, so that instead of all germ life.

Experiments are now being carried out in using chlorine as a cure of colds, so that instead of being injurious to our health, it may be beneficial if diluted sufficiently with air.

**ENERGY**

(1735) John M. Wetherill, Schnecktady, New York, asks:

Q. 1. What is energy and what are its manifestations?

A. 1. Energy is the capacity for doing work. There are three classes of energy: energy of masses, energy of molecules and atoms and energy of ether.

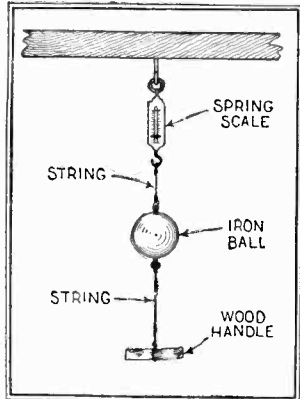

Were a gradual pull exercised upon the handle, the upper string would break first; as here the total pull on that string would be the pull plus the weight of the iron ball. When a sudden pull is applied, the lower string breaks first, as the inertia of the ball is so great as to keep it from moving before the upper string breaks.

Masses in motion—kinetic  
 Elastic bodies in state of stress. } potential  
 Gravitation, energy of attracting masses.  
 Sound—kinetic & potential

Energy of molecules and atoms. { Heat  
 Molecular & atomic energy  
 Chemical action.

Energy of ether { Light & Radiation  
 Electric and magnetic phenomena

Q. 2. Kindly define inertia and give an example?

A. 2. Inertia is the tendency of a body to remain in its state of rest or motion. If a heavy iron ball is suspended by means of a light cord and another similar cord fastened to its lower end, a sudden pull on the lower string will result in that string being broken. The string supporting the iron ball will not be broken. The reason for this is that even before the heavy mass had a chance to move, the lower string was strained to the point where it was broken. If a spring scale were attached to the upper string, it would show little increased reading.

**PLATE SUPPLY**

(1736) Paul McKinley, West Point, Kentucky, asks:

Q. 1. Can a 32 volt farm lighting plant supply line be used as a source of plate voltage for a WD-11 tube?

A. 1. The 32 volt farm lighting supply plant can be used successfully if you place a 2 mf. condenser across the tube and put a 30 ohm rheostat in series with one leg. It is advisable of course to use this for the detector tube only, as there is not sufficient voltage to operate an amplifier tube very successfully.

**FAST GUN POWDER**

(1737) Joseph Bartos, Dayton, Ohio, asks:

Q. 1. Can you give me a formula for a good fast burning gunpowder, also a sure burning fuse for fireworks?

A. 1. Probably the simplest formula for you to follow for making gunpowder is the following:

- Potassium nitrate, 75 parts.
- Charcoal, 15 parts.
- Sulphur, 10 parts.

These parts are by weight. It is quite necessary that all the above ingredients be entirely pulverized before mixing, ground in water, dried to a cake, and pulverized.

For fuses the following is used:

- Potassium nitrate, 2 parts.
- Lead acetate, 40 parts.
- Water, 100 parts.

Mix and dissolve, and in the solution place unsized paper; raise to nearly a boil and keep at this temperature for 20 minutes. If the paper is to be "slow," it may now be taken out, dried, cut into strips and rolled. If to be "faster," the heat is to be continued longer, according to the quickness desired. Care must be taken to avoid boiling, which might disintegrate the paper. In preparing these papers, every precaution against fire should be taken, and their preparation in the shop or house should not be thought of. In making the solutions, etc., where heat is necessary, the water bath should invariably be used.

**FLASHLIGHT POWDER**

(1738) Arthur T. Snyder, Springfield, Idaho, asks:

Q. 1. What is the formula and how is flashlight powder made?

A. 1. Flashlight powder is composed of 6 parts of magnesium dust or powder, to which has been added 12 parts of potassium chlorate. In another dish, 4 parts of aluminum dust, 10 parts of potassium chlorate and 1 part of sugar

are thoroughly mixed and the both mixtures, which of course are in a finely divided state, having been completely pulverized separately, are mixed together. Care should be taken in handling to prevent inhaling.

**LINEAR EXPANSION**

(1739) William J. Hayes, Mulvane, Kansas, says that it is best to put up electric telegraph wires in the summer, while a friend of his says it is best in the winter. Kindly explain who is right.

A. 1. The general practice is to string telegraph wires during the summer and autumn, stringing them as tightly as is consistent with average temperature. Between the extremes of summer heat and winter cold, an average temperature change of 50° Centigrade is not at all uncommon, and a steel wire one mile long will change as much as three feet in length during this period, showing that the wire, if strung too tightly, will pull the insulators from their supports, or if strung too loosely, will, during the summer, sag greatly.

**FOUR CYCLE GASOLINE MOTOR**

(1740) Oscar Lamond, Baltimore, Md., asks Q. 1 Will you kindly explain in full detail how the four cycle gasoline motor operates?

A. 1. Vaporized gasoline and air are fed into the firing chamber on the first cycle, the piston drawing the explosive mixture into the cylinder. During the next cycle this explosive is

**IMPORTANT**

**TO NEWSSTAND READERS**

IN order to eliminate all waste and unsold copies it has become necessary to supply newsstand dealers only with the actual number of copies for which they have orders. This makes it advisable to place an order with your newsdealer, asking him to reserve a copy for you every month. Otherwise he will not be able to supply your copy. For your convenience, we are appending herewith a blank which we ask you to be good enough to fill in and hand to your newsdealer. He will then be in a position to supply copies to you regularly every month. If you are interested in receiving your copy every month, do not fail to sign this blank. It costs you nothing to do so.

To \_\_\_\_\_ Newsdealer

Address \_\_\_\_\_

Please reserve for me \_\_\_\_\_ copies of SCIENCE & INVENTION every month until I notify you otherwise, and greatly oblige.

Name \_\_\_\_\_

Address \_\_\_\_\_

compressed in the cylinder by the rising piston due in part to the momentum of the flywheel and before the downward stroke, a spark passes which is automatically controlled by the timer. The piston returns, forcing the waste gas out on its up-stroke and starting at the beginning of the fifth cycle, the above operation is repeated. This assumes the crankshaft to be below the cylinders. The engine can work in any position.

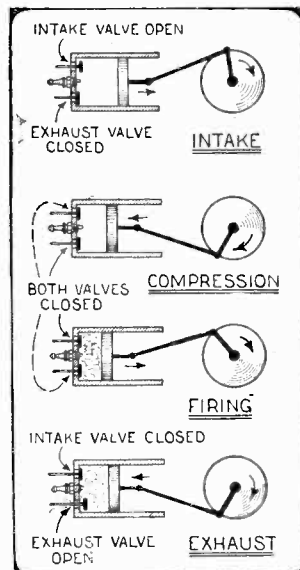

The gasoline engine of today is one of our marvelous inventions, which we so much abuse when driving our car. A simple explanation of how it works, is augmented by the diagram shown. Although very simple in principle, the design of a complete engine entails a very intricate and extensive series of calculations. Speed, strength of materials, lubrication, bearings, valves and heat generated, are some of the factors which the engineers cope with. A two cycle engine does the same work as the four, but in only two operations.

**PIEZO ELECTRICITY**

(1741) Charles Rubitchek, Glen Head, Long Island, asks:

Q. 1. What is so-called piezo electricity and why is it so called?

A. 1. Piezo comes from the Greek word in the infinitive mood, "piezein," which means to squeeze or press. Many solids in crystal form develop powerful electrical currents when subjected to stress, particularly torsional stresses.

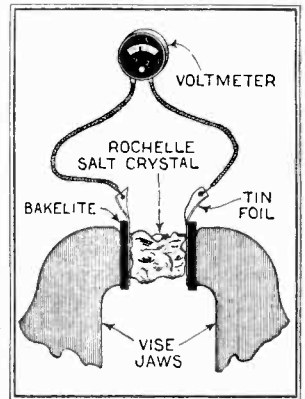

A Rochelle salt crystal clamped between the jaws of a vise, and insulated therefrom by bakelite strips, is connected to a voltmeter, and upon tightening the vise, a voltage deflection occurs. Of course the current is small, but if a battery of the cells are connected in parallel, more current will result. Upon passing a telephone current through the crystal the crystal talks.

In the same manner many crystals act in the reverse manner and produce stress when electrical charges are applied to them. By this means we have, obviously a system of converting electrical into mechanical energy and vice versa. These crystals also have the property of rotating the vibratory plane of polarized light and are thus optically active. Among the common substances acting in this manner, are camphor, sugar, quartz, and many solids having asymmetric crystalline structure. Ordinary Rochelle salt crystals seem to give the greatest piezo electrical action and build up remarkably high potentials. Although the action was first discovered in 1880 by Curie, very little has been done in the way of utilizing the effects of the crystal in commercial practice. A great field is open for experimentation along these lines.

**CARE OF STORAGE BATTERY**

(1742) Mortimer Shapiro, Portland, Oregon, says that he has recently purchased a new storage battery and is desirous of learning the best means of prolonging its life. He asks:

Q. 1. What are the causes for the poor longevity of a storage battery?

A. 1. The three classes of trouble to be encountered with in the use of a storage battery are 1, chemical, 2, electrical and 3, mechanical.

When once put into action, a battery should be used continuously and with the proper care will last five years or more. It should be kept in a clean, dry and cool spot. It should be recharged as soon as there is a noticeable drop in voltage. The electrolyte should always be at least one-half inch above the top of the plates.

Care must be taken to prevent the jars, whether of glass or rubber in the battery breaking or cracking. All terminal connections must be kept clean and the vent holes kept open. Allowing the battery to freeze does as much material damage as does excessive overcharging.

At the specific gravity reading of 1300 and the terminal voltage of two and a quarter volts, a battery cell is fully charged. When the specific gravity falls to 1200 and the voltage to 1.8 volts, it is imperative for the good of the battery to recharge it. The ordinary six volt, 100 ampere hour battery used on automobiles should not be charged at a faster rate than five amperes.

**CEMENT FOR MEERSCHAUM**

(1743) Rufner Thompson, Logan, W. Va., says that he has accidentally broken an heirloom pipe and desires to repair it. He asks:

Q. 1. How can I go about it?

A. 1. Macerate several pieces of fresh garlic, having stripped them from their outer hull. This can be done in a mortar, until reduced to a paste.

Dip the broken ends on the pipe into the paste and quickly join the ends, clamping together as tightly as possible. Immerse the joint in some boiling milk and allow to remain for one-half hour, after which remove and allow to cool slowly.

This makes a practically invisible joint which will withstand ordinary rough usage.

**STAMPING ON METALS**

(1744) John E. Monahan, Dorchester, Mass., wants to know:

Q. 1. Can you give me a process for marking on steel and brass which has been coated with a thin coat of varnish? I want to accumulate the ink and by using a rubber stamp, cut through the varnish and so impress the stamping directly on the metal objects.

A. 1. We do not believe that it is very practical to mix an acid with ink in order to cut through varnish so as to stamp on steel directly. We believe it is much more advisable to use a heated die which will clean the varnish from the steel, and then apply the ink, after which it can be revarnished.

# Awards in \$1000 Monthly Contest

The Regular Departments Pay Prizes of Their Own. Authors on Contract Receive Their Own Rates; this, With Other Special Payments Makes the Total Paid for Articles in Excess of \$1500.00 Monthly.

## FIRST PRIZE \$100.00

"Flame Thrower in African Jungles," by J. G. Frederick..... 446

## TWO PRIZES OF \$50.00 EACH

"What Causes the Aurora Borealis?" by Donald H. Menzel, Ph.D..... 448  
 "The House Fly—Its Extermination," by Dr. Ernest Bade..... 450

## TEN PRIZES OF \$25.00 EACH

"At Last! Wind Power," by C. A. Oldroyd, A.E., Reporter No. 4433.. 447  
 "Collapsible Dirigible Mast," by Ernest Brennecke..... 452  
 "Blood Circulation System Models," by Dr. Albert Neuburger..... 453  
 "Flyers Skim Top of Hawaiian Volcano," by Lt. C. P. McDarment... 454  
 "Rocket Life-Line Anchor," by J. W. Johnson..... 456  
 "Electricity—Destroyer of Airships," by C. A. Oldroyd, Reporter No. 4433..... 467  
 "Canvas Canoe Construction," by Dr. Ernest Bade..... 480  
 "Hairpin Surgical Instruments," by W. C. Michel..... 482  
 "The Ritz Super-Neurodync,"—Charles C. Ritz..... 490  
 "A Three Tube Receptor," by W. L. Pearce..... 491

## FIVE PRIZES OF \$20.00 EACH

"Cigar Lighter and Help for Autoists," by L. Fournier..... 453  
 "The Telemeter—A New Range Finder," by Ernest Brennecke..... 467  
 "Uses For Old Spools," by Walter Markowski..... 481  
 "Telegraph Circuit Receives Radio," (For suggestion), Prof. Eugene Bobrowski..... 485  
 "Philadelphia's Radio Entertainers," by Samuel Lovenstein, Reporter No. 4018..... 487

## TEN PRIZES OF \$15.00 EACH

"European Advances in Science," by L. Fournier..... 455  
 "A Super-Sensitive Microphone," by Ernest Keil..... 455  
 "The Oyster's Body," (Author please send name and address)..... 456  
 "Game Incorporates DX Thrill," Author of article..... 465  
 "New Jazz Instrument," by Alexander Kolbe..... 465  
 "Nature Heats Houses," by L. Pim, Reporter No. 4129..... 469  
 "Fly Screen and Pneumatic Wheel," by J. W. Von Stein..... 469  
 "Ratchet Jack Device," by E. W. Brantigan..... 474  
 "Uses For Broken Tools," by T. B. Sage..... 480  
 "Microscopic Drawing," by Prentice E. Tugardin..... 481

## TWENTY PRIZES OF \$10.00 EACH

"Ice Experiment," by Dr. Albert Neuburger..... 466  
 "Handy Locator for Map," by Mr. Pleasant..... 469  
 "Aquarium," by J. W. Paetznick..... 466

"Small Cacti Craze," by S. Leonard Bastin..... 466  
 "Detective Camera," by Chet. Shater..... 469  
 "Fair Weather Indicator," by S. Leonard Bastin..... 469  
 "Phonograph Novelty," by Robert A. Rummel..... 470  
 "Easily Performed Trick," by Franklyn Kenchion..... 470  
 "Knee Shift Key," by Lester Sargent..... 474  
 "Music Abacus," by E. W. Cornell..... 474  
 "Hand Sewing Machine," by H. W. Garland..... 474  
 "Socket Wrench," by A. O. Cochran..... 474  
 "Hose Kink," by George Arthur Luers..... 481  
 "A Radio Kiss," (Author please send name and address)..... 488  
 "Rotary Switch," by William B. Chambers..... 524  
 "Positive Contact Switch," by George Martin..... 524  
 "Phonograph Attachment," by Paul F. Bryant..... 526  
 "Rotor Support," by Russell Erwin..... 527  
 "Multiple Detector," by C. A. Oldroyd, Reporter No. 4433..... 527  
 "Simple Wave Trap," by Nestor Barrett, Reporter No. 6425..... 528

## TEN PRIZES OF \$5.00 EACH

"Telegraph" Plant by S. Leonard Bastin..... 470  
 "Shoe Preserver," by Ernest Keil..... 470  
 "Warning," by Lyman Mason..... 483  
 "Microscope Kink," by C. A. Oldroyd, Reporter No. 4433..... 483  
 "Clip Kink," by Wilson Walters..... 483  
 "Simple Gas Generator," by Dr. Ernest Bade..... 484  
 "Universal Control," by Paul Huntsinger..... 522  
 "Battery Switch," by J. T. Garver..... 523  
 "Portable Aerial," by Milton H. Cash, Reporter No. 7152..... 523  
 "B Metal" Detector, by Bonnie Chambers, Reporter No. 2254..... 529

## TWENTY PRIZES OF \$2.00 EACH

"Bleacher," by C. Gauer..... 484  
 "Feather X-ray," by Frank R. Merre..... 484  
 "Graduate Kink," by J. H. Paulson..... 484  
 "Aerial Suspension," by Harry R. Lubcke, Reporter No. 1015..... 522  
 "Aerial Insulator," by Harold Jackson..... 525  
 "Tap Kink," by W. E. Leach, Reporter No. 3127..... 525  
 "Reinartz Coil Pattern," by Daniel R. Axford..... 525  
 "A Convenient Loop," by Abbott D. Corkum, Reporter No. 5275..... 526  
 "Novel Switch," by Veil A. La Vanway..... 528  
 "Anti-Twist Phone Cord," by B. G. Switzer..... 528  
 "Quick Throw Aerial Switch," by W. R. Daniels..... 529  
 "Using 'B' Battery as 'C' Battery," by John Bruen..... 529

(No Further Entries)

## TEN PRIZES \$1.00 EACH

(No Entries)

### Here Is How You Can Get in the Contest:

#### \$12,000 or More in Gold

EVERY month SCIENCE AND INVENTION pays \$1,000 or more in gold in prizes. Every text article published will receive a prize—(most of the departments have awards of their own which they give every month). Ideas are what the Editors want. The ideas must be told simply, so that your mother or your sister can understand them—in pictures or sketches or both. But the idea must be new and must have something to do with science or invention.

The Editors want pictures and sketches—must have them—but what they want most

88 monthly prizes will be given as follows:

#### FIRST PRIZE \$100.00

2	PRIZES	of	\$50.00	each
10	"	"	25.00	"
5	"	"	20.00	"
10	"	"	15.00	"
20	"	"	10.00	"
10	"	"	5.00	"
20	"	"	2.00	"
10	"	"	1.00	"

#### \$12,000 or More in Gold

is IDEAS. These ideas will be handsomely paid for. We have published a pamphlet showing the rules of the contest which we shall be glad to send to anyone free on receipt of a postal card with your name and address. The pamphlet gives full details, the rules and how to submit articles. The magazine itself shows you what is wanted. Study it closely and submit your ideas.

The closing date for all prize contributions is the 15th of the month preceding date of issue, i.e., the 15th of Sept. for the Nov. issue, the 15th of Oct. for the Dec. issue, etc.

### WILL YOU BE OUR REPORTER?

IN connection with our \$12,000 prize contest announced herewith, it goes without saying that you will have to do a little work in order to win a prize. The Editors do not wish to make it hard for you, quite the contrary. We want pictures and ideas and we cannot have too many of them.

Herewith is reproduced our reporter's card. Up to now we have issued over 13,000 of these. Note in our awards how our reporters are winning prizes right along. We shall be glad to send the reporter's card free to anyone who makes an application for it. By means of this card you will be able to secure entry into industrial plants, business houses, motion picture studios, steamships, docks, public buildings, etc. This reporter's card will prove an open sesame to you in many instances. Every card is numbered and only one is given to a correspondent. A postal card from you and a request for this reporter's card is all that is necessary to obtain one. It will be sent to you by return mail. With it we will send you a pamphlet giving rules of the contest and how to proceed in order to get photographs, to send in sketches, and other information in order to obtain a valuable prize. Not only will this card help you to obtain material for this magazine, but it will train you to become a news gatherer, and will be the means of helping you to earn a good deal of money during your spare hours.

Address Field Editor, SCIENCE AND INVENTION, 53 Park Place, New York

REPORTER



**Science and Invention**

CORRESPONDENT  
REPORTER'S  
IDENTIFICATION

NO. 10000

*L. H. Shackner*

THE BEARER OF THIS CARD IS AN AUTHORIZED CORRESPONDENT-REPORTER OF SCIENCE AND INVENTION MAGAZINE. THE PUBLISHERS OF SCIENCE AND INVENTION WILL APPRECIATE ANY COURTESY EXTENDED THEIR REPRESENTATIVE.

EXPERIMENTER PUBLISHING CO.

*Herbert Ball*  
PRESIDENT

*At Last* /

**A PRACTICAL  
HAND BOOK for the MOTOR MACHINIST  
and AUTO REPAIR MAN**

*The Book you've been looking for*

Here it is—the Starrett Book for Motor Machinists and Auto Repairmen; first and only book of its kind ever published. Over 200 pages of data on the maintenance and repair of autos and trucks and when you look it over you'll say three loose quarters never brought more value.

This Handbook has been prepared by authorities in the automotive world. Written for the man in the shop. Profusely illustrated. Diagrams. Tables. Well printed. Bound in handsome red Athol-leather. Handy size (4 3/4" x 7 1/4") for carrying in pocket. In every way Volume III of the Starrett Books is a fitting companion to Volumes I and II (The Starrett Book for Machinists' Apprentices and The Starrett Data Book for Machinists) of which nearly 100,000 copies have been bought by skilled machinists as well as those learning the metal working trades.

If you work on a car this Starrett Book will pay for itself a hundred times over. Get it for 75c. at any hardware store selling Starrett Tools. If there is no dealer near you, send 75 cents and we will mail you a copy with charges prepaid. Whichever you do—ACT PROMPTLY. The first edition is limited and these practical handbooks will go fast.

Write for the new Starrett Catalog No. 23 "LE" describing over 2200 fine Precision Tools for Machinists, Auto-Repairmen, Carpenters and Mechanics.

**THE L. S. STARRETT CO.**

*The World's Greatest Toolmakers*  
Manufacturers of Hacksaws Unexcelled  
ATHOL, MASS.

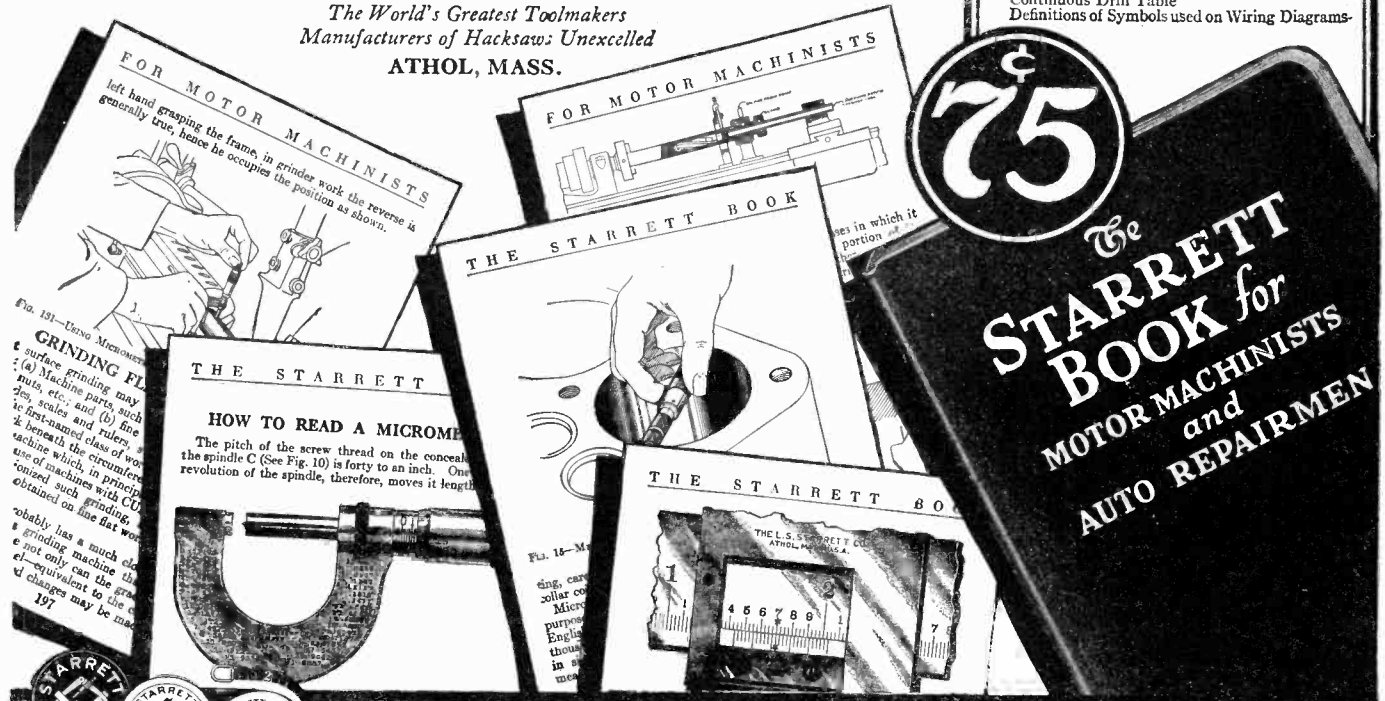

**The Book that shows  
how to do it right!**

*Partial Table of Contents*

- LAYING OUT WORK
- DRILLING (selecting speeds and feeds, grinding drill points, counterboring, etc.)
- TAPPING (regrinding taps, removing broken taps, use and care of dies, etc.)
- REAMERS AND REAMING
- FILING
- HACKSAW CUTTING
- GRINDING (wheel selection, mounting, dressing, lapping, etc.)
- LATHE WORK (care, indication, adjusting, locating centers, setting tools, testing, turning, checking)
- HOW TO READ AND THE ADJUSTMENT OF MICROMETERS
- MILLING AND MILLING MACHINES
- THREAD CUTTING
- FITS AND FITTING
- GAGING CYLINDER BORES
- PISTON GRINDING
- FITTING PISTONS AND PINS.
- CYLINDER HONING
- LAPPING CYLINDERS
- VALVE FITTING
- FITTING CRANKSHAFT AND CON-ROD BEARINGS
- ADJUSTING TAPPETS
- SHIM FITTING
- DECARBONIZING
- THE ACETYLENE TORCH
- WELDING, SOLDERING AND BRAZING
- CHAIN DISCOUNTS (how to figure)
- DEFINITION OF ELECTRICAL TERMS

**Tables Covering**

- Decimal equivalents of Fraction of an Inch
- Depth of drilling necessary to remove given weights of different metals when balancing machine parts, etc.
- Assortments of Drills for Tapping
- Melting Points of Metals
- Piston Displacements
- Wire and Sheet Metal Gages
- Wood Screw Specifications
- How to tell Carburetor sizes
- Anti-Freezing Solutions
- Maximum Power Required to Drive Machine Tools
- Equivalent Annular Ball Bearings
- Horsepower Table by N. A. C. O. Formula
- Grades of Grinding Wheels
- Grain Numbers Commonly used in various polishing operations
- Woodruff Key Sizes
- Rules for Figuring Tapers
- Cutting Speeds and Feeds for Turning Tools
- U. S. Standard Screw Threads
- Tap and Body Drills
- Taper Reamers for Standard Taper Sockets
- Wrench Sizes for Bolts, Nuts and Cap-Screws
- Continuous Drill Table
- Definitions of Symbols used on Wiring Diagrams



*The* **Starrett Book** *for* **MOTOR MACHINISTS AND AUTO REPAIR MEN**

# \$90 Drafting Course FREE

There is such an urgent demand for practical, trained Draftsmen that I am making this special offer to deserving, ambitious men. I will teach you to become a Draftsman and Designer until you are drawing a salary of \$250.00 a month. You need not pay me for my personal instruction or for the complete set of instruments. **But you must take advantage of this special offer at once.**

# \$300 a Month Salary— \$450 on the Side At Home

That's the kind of money my drafting students make. Read what this one says:



"As a beginner I am doing fine. Am earning a salary of \$300 per month, besides I made over \$450 at home the last two months, drawing plans for private parties. The practical drafting training you gave me by mail put me where I am in less than six month's study. Thank you for all your personal interest and help you gave me so far." (Signed) J. B. (Name and address upon request)

Write and I'll tell you how I make you a first-class, big-money-earning draftsman in a very few months! I do this by a method no other man or institution can imitate. I give you personal training at home by mail until you are actually placed in a position paying up to \$250 and \$300 a month. Six thousand draftsmen wanted every month.

### I Guarantee

To train you until you are placed in a position paying up to \$250 and \$300 a month

## This Outfit FREE

I give you a whole set of drafting tools the minute you become my student. You get every tool you need. A magnificent set of instruments which will build your success in draftsmanship.

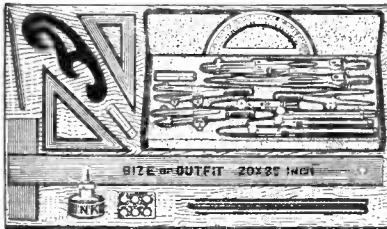

## Mail Coupon

at once for my great book — "Successful Draftsmanship." Find out about the simply marvelous opportunities ahead now. What great salaries and possibilities there are! Send the coupon for free book TODAY!

### Free Course Offer Coupon

CHIEF DRAFTSMAN DOBE  
1951 Lawrence Ave., Div. 14-26 Chicago

Without any obligation to me please mail your book, "Successful Draftsmanship" and full particulars of your liberal "Personal Instruction" offer to a few students. It is understood I am obligated in no way whatever.

Name.....Age.....

Address.....

## Doctor Hackensaw's Secrets

By CLEMENT FEZANDIE

(Continued from page 461)

preferable! Silas, you've no idea what marvels this new invention of mine will lead to. It will absolutely revolutionize commerce and industry. Long before I discovered my gravitation screen, I experimented with such a railroad, using a balloon as a motive power, letting out ballast on the downhill slope. I even used kites, a special device enabling me to increase or decrease the surface exposed by the kite according as to whether I was ascending or descending the hill. My acquired velocity of course carried me over the neutral point at the top of the hill. How easy to raise a sunken ship with all its cargo by letting sheets of this anti-gravitation metal down into the water edge-wise and then sliding them beneath the sunken vessel. And what need of steamers anyway. Load up your ship with a full cargo; screen off enough gravitation so the ship will rise a mile above the ocean and pull it to its destination by means of one or more airplanes harnessed to it. If you wish greater power, you can have the aerial ship

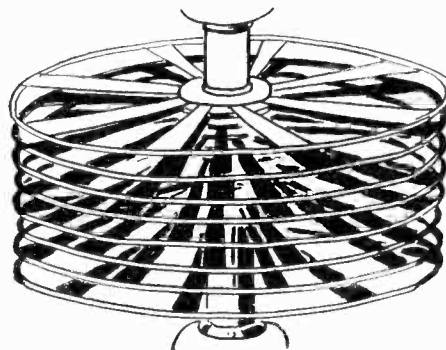

Above is a view of the vanes used by Dr. Hackensaw's vehicle to cut off the effects of gravitation from the car.

drawn by a steam-tug. The tug has the resistance of the water to serve as an abutment, while the ship in the air has only the resistance of the air to drive against.

"Then, too, think of the advantage of my gravitation screen to architects and others. You can carry a house from one city to another through the air. The house-trust can manufacture houses by the thousand in one spot, using efficiency methods and quantity production. Then it will deliver the finished house on a man's own lot. And houses will not be solidly fixed to the earth. When you want to go off for a summer vacation with your family, you will take your whole house with you. One of the greatest obstructions to the progress of a city is the out-of-date dwellings it contains. How easy it would be to improve a city if we could cart away to the country all the rickety old houses of the slums and lay out the city with wide streets of up-to-date buildings.

"As to the uses of my invention for war-purposes, they are practically unlimited. Think of the advantage of being able to fly over the mountains with heavy artillery or with regiments of soldiers and ammunition and provisions of all sorts. Think of what you could do with a flying fort. You could land your fort right in the middle of your enemy's chief city or on his line of railroad, and cut off his supplies. You could very easily cause whole armies to surrender without the loss of a man.

"But now, Silas, I'm going to show you the jewel of my collection. I'm going to show you my air express—capable of carry-

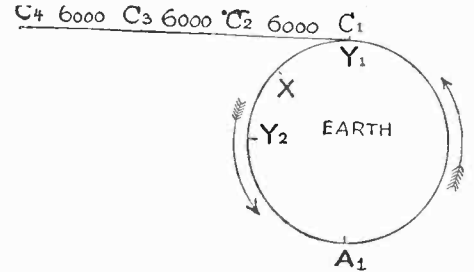

If gravity is automatically released from an object on earth, said object will fly off from the earth at a tangent and at a certain definite speed, never gaining or losing as long as it is not interfered with by the attraction of some other body.

ing merchandise from one part of the earth to another at the rate of ONE THOUSAND MILES PER HOUR!

### CHAPTER 3

#### DOCTOR HACKENSAW'S AIR EXPRESS

"I think I have solved the problem of cheap and rapid transportation, Silas," continued the doctor, as he led him into a large hangar in the center of which was a large cylindrical car from the bottom of which projected a smaller cylinder.

"Here, my boy, is my air-express," observed Doctor Hackensaw impressively. "Here is a car that can defy the laws of gravitation and travel one thousand miles per hour without the need of a propeller or a motor of any kind. Gravitation and anti-gravitation do the whole work. The only power required can be supplied by a fifteen-year-old boy. Yet this car can reach a place twelve thousand miles away in twelve hours. What do you think of that?"

"I confess I don't understand it," replied Silas. "Does it work the same way as your mountain climbing car?"

"No indeed. The principle is entirely different. This car takes advantage of the rotatory speed of the earth on its axis, for, as you know, the earth turns one thousand miles every hour. When you were a boy, Silas, you must have wondered why people who took a twelve-hour balloon-ride did not find themselves at the Antipodes when they landed. The reason is, of course, that our atmosphere spins around with the earth, the lag being very slight. If, however, we could get a car up above the air—and screened from the attraction of the earth, it could wait there while the earth spun around, and when the car came down twelve hours later, it would find Australia waiting for it at the spot where it had left New York.

(Continued on page 502)

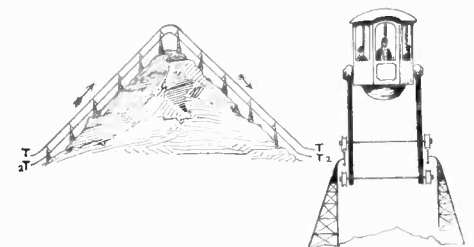

Above is Dr. Hackensaw's hill-climbing car which uses the negation of gravitational force for carrying the car over and letting it down gently on the opposite side of the hill.

# "BUILD YOUR OWN" WITH "RASCO" PARTS!

Buy from the Oldest and Original Exclusive Radio Parts House in the United States

We pay ALL transportation charges in U. S. ALL GOODS SENT PREPAID IN 24 HOURS

Order direct from this page.

**NEW AND EXCLUSIVE "RASCO" GOODS**

Money refunded if goods do not satisfy



## ZINCITE DETECTOR (PATENTS PENDING)

Here is a detector which has been especially developed by us for the new Crystodyne circuits. This detector while using the natural mineral zincite can be used with any other crystal as well. Several unique features are embodied in this detector. To begin with it is the only detector that has a sliding crystal cup with perfect contact arrangement and which cup not only slides but rotates with an eccentric motion. (Note slot A). By means of the small knob the cup slides easily so that any point of the crystal can be brought into contact. A new crystal can be inserted immediately by unscrewing the small knob. The contact plate which at the same time forms the catwhisker is made of spring steel. The combination of steel-zincite is the only one that was found practical for the Crystodyne oscillating crystal. Note the micrometric adjustment that can be made by means of the large knob bearing against the steel spring. This raises and lowers the steel point to the finest possible degree. The base is of bakelite, all parts nickel plated and polished. \$6900-Crystodyne Zincite Detector .....\$1.75 \$6900-Natural Mounted Crystal especially tested for Crystodyne work, fits any crystal cup .....\$0.60 (Note: Natural zincite is the ONLY mineral which in connection with a fine steel point will produce sustained oscillations in the Crystodyne circuits. Natural zincite is one of the most expensive minerals and the supply has been practically exhausted. It sells now from \$25.00 to \$30.00 per lb. in the open market. Artificial zincite, a much inferior article, will not produce oscillations at all.)

## "RASCO" Double Acting Snap Switch

At last a REAL radio switch constructed for radio purposes, not just a battery switch that may be adapted for radio. The RASCO switch is the only switch with a POSITIVE DOUBLE spring action. No more guess work if the circuit is open or closed. A push of the finger and the current is on. A slight pull and The Handle Snaps Back of its own accord. An internal coil spring pushes the handle back when a little pull is applied. This switch is intended as a battery switch to disconnect your "A" batteries. Only one hole to drill. No tools required to mount except your finger and thumb. Also this switch takes up a minimum of room, much less than other switches, the base of the switch measuring only 1 1/4 x 1/2". All metal parts nickel plated. A switch you will be proud to possess. No. S4850-RASCO Snap Switch, Each.....25c

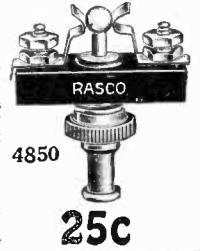

## 16 in 1 Radio Tool 35c

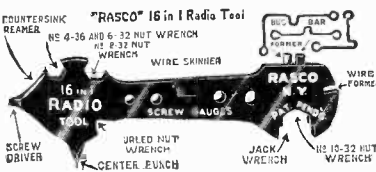

Here it is! The radio tool that will bring happiness to all radio experimenters and constructors. Here is a tool that does 16 different things and does them well. A tool that does practically everything required in building your radio set. The tool is built of hardened steel, exactly as per illustration, highly finished. Here are some of the uses: 1. Screwdriver. 2. Center punch. 3. Countersink. 4. Bus bar wire bender. 5. Bus bar and wire bender for 8/32 screw. 6. Bus bar and wire bender for 6/32

screw. 7. Socket wrench for jacks. 8. Socket wrench for 4/32 nuts. 9. Socket wrench for 6/32 nuts. 10. Socket wrench for 8/32 nuts. 11. Wrench for knurled nuts. 12. Screw gauge for 1/32 screws. 13. Screw gauge for 6/32 screw. 14. Screw gauge for 8/32 screw. 15. Screw gauge for 10/32 screw. 16. Knife for wire skinning. These are only the important uses of the tool, but many other uses will readily suggest themselves to every radio experimenter. You will wonder how you have gotten along before without the 16 in 1 radio tool. Get one of these happiness tools. You will never again be without it. Size 4 1/2 x 1 1/2 in. No. S-1800 RASCO 16 in 1 Radio Tool, each.....\$0.35

## "RASCO" "Jiffy" Jacks and "Jiffy" Plugs

Again, Rasco leads with a small but important radio novelty. JIFFY JACKS are the simplest, and most efficient Cord Tip Jacks ever designed. Stamped from a single piece of metal they grip any style cord tip from any make phone or loud speaker. The JIFFY JACKS take but a minimum of room. All you need to do is to drill two small holes in your panel and mount the JIFFY JACK with screw and nut furnished. No soldering necessary as the wire goes right on the screw. X-ray view shows how two of the jacks are used in conjunction with our Jiffy cord plug. The jacks go on in back of panel, only screws show in front. JIFFY JACKS take practically no room when mounted and are made of best spring brass that will not wear out. Hundreds of other uses for our JIFFY JACKS. We will pay \$1.00 for every new idea for JIFFY JACKS that is accepted by us. JIFFY PLUGS are made of semi-hard rubber into which the tips of your phones or loud speaker are pushed. The cheapest and simplest plug ever designed. Its small size and neatness made it famous over-night. Size 1 in. long, 1/2 in. wide and 3/4 in. thick. No

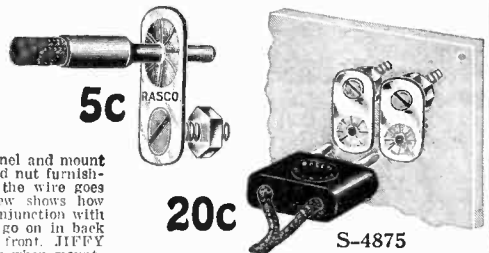

tools required. Just wet the metal cord tips and push through openings. Plug can be used with any standard cord tip jack, but best with RASCO JIFFY JACK. S-4875-Two Jiffy Jacks with nuts and screws and one Jiffy Cord Plug.....\$0.20 S-4870-One Jiffy Jack complete with nut and screw.....0.05 S-4871-Jiffy Jacks without nuts or screws, two for.....0.05 S-4860-Rasco Jiffy Plug, each.....0.10

## COMPLETE SET SALE AT REDUCED PRICES

**Reinartz Receiver**  
Exactly as shown with mahogany cabinet, panel, all necessary instruments, binding posts and pattern for assembling. This set can be put together by anyone in a few hours.  
S9988 Reinartz Receiver .....\$13.50

**Autoplex Circuit**  
Will bring broadcast on loud speaker or on single tube. Complete as pictured here. All 11 parts, including mahogany cabinet, panel, instruments, binding posts, etc. can be put together in a few hours time.  
S9955 Autoplex outfit .....\$15.00

**Wanted**  
This Company is always in the market for new ideas. Any small specialties in demand by the radio fan will be highly welcomed by us. Some of the articles shown on this page originated with our customers, whom we paid well for the ideas. Send your sketch or model addressed to Research Department, c/o this Company.

**Dealers and Jobbers**  
Write or wire for territory that is still open on the specialties described on this page. These articles are widely advertised and you will have a demand for them almost immediately. We shall be glad to send samples to responsible and rated concerns. Address all wholesale inquiries to  
**RADIO SPECIALTY COMPANY.**  
Wholesale Department,  
25A West Broadway, New York City

75 VACUUM TUBE BOOK UPS 350 ILLUS 350 ARTICLES 84 PAGES FREE

Molded Variometer  
Highly substantial instrument. Silk windings. 3/4" shaft. Plug in when placed into AB direction makes instrument panel mounting. 180 to 650 meters. Money back if this instrument is not all that we claim for it.  
S3350 Variometer \$3.00

FONEKUSHIONS  
Made of sponge rubber. Make wearing your receivers a pleasure. Positive-ly exclude all noises and make reception a pleasure. Spongo rubber will last for years. Light as a feather.  
S3550 Fonekushions, set of two .....\$0.50

Straight Line Condenser  
Simplest and most practical type of condenser.  
S4430 "Rico" Condenser .001 mfd. 43 plate capacity .....\$1.75 S4230 .0005 mfd. 23 plate capacity .....\$1.75 S4110 .0025 mfd. 11 plate capacity .....\$1.75 All types no dials \$1.50

Radio Frequency Transformers  
Best Radio Frequency Transformer developed so far. Designed by R. E. Lacaute, Associate Editor RADIO NEWS. Air core type. 200-600 meters.  
S2800 Transformer, size 1 7/8" x 2 1/2" .....\$1.50

Spaghetti  
Varnished flexible cambric tubing. 319 takes No. 22 wire; 320 takes 18 to 20 wire; 21 takes 16 to 18 wire; 314 takes 22 to 28 wire.  
S319-320-321 Per ft. \$ .08 S344 Flexible soft rubber tubing; 10 feet for. \$ .20

Soldering Iron  
Smallest and handiest made. Fits any flat iron or percolator plug. Plug then becomes handle. 5" long. Complete but without plug or wire.  
S2200 Soldering iron .....\$1.45

**FREE**  
The big "Rasco" catalogue. Contains all A r n s t r o n g circuits. Every up-to-date vacuum tube hook-up. Greatest little book printed. Free upon receipt of

Dial Marker  
The big little thing you have been waiting for. Just drill a hole in the panel and mount the marker above the dial. Nickel plated and polished.  
S7788 Dial Marker, each .....\$0.05

vacuum Tubes  
Only best make tubes carried in stock. Any tube replaced if defective. Providing filament lights.  
S201A 5 v., .25 amp. \$2.50 S199 3 v., .08 amp. 2.50 S12 1 1/2 v., .25 amp. 2.50

Three-Gang Socket  
Aluminum shells, genuine heavy bakelite base. 3 brackets for mounting. 12 nickel binding posts. Length 7 3/4".  
S5995 3 gang socket \$1.50

Cockaday Coil  
Guaranteed best make. Three windings of No. 18 Magnet wire. Has brass brackets for panel or base mounting. Guaranteed of money back.  
S2750 Cockaday coil \$1.50

Neutralizing Condenser  
Latest pattern. Genuine bakelite base. Fabnstock connectors, hard rubber composition knob, easiest to regulate. Size 5 1/2" long, 1" wide.  
S202 Neutralizing condenser .....\$ .40

Neutro-Transformer  
Can be used for all tuned radio frequency circuits. Made for usual broadcast waves. Secondary has one center tap. Two genuine bakelite tubes.  
S6909 Neutro-transformer .....\$1.65

## NEW THINGS FROM CATALOG No. 11 AT CUT PRICES

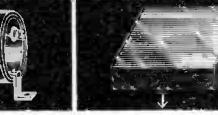
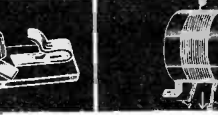
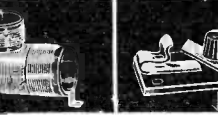
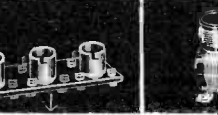
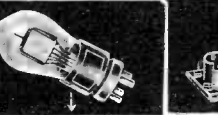
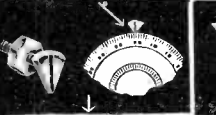

The big little thing you have been waiting for. Just drill a hole in the panel and mount the marker above the dial. Nickel plated and polished.  
S7788 Dial Marker, each .....\$0.05

Only best make tubes carried in stock. Any tube replaced if defective. Providing filament lights.  
S201A 5 v., .25 amp. \$2.50 S199 3 v., .08 amp. 2.50 S12 1 1/2 v., .25 amp. 2.50

Aluminum shells, genuine heavy bakelite base. 3 brackets for mounting. 12 nickel binding posts. Length 7 3/4".  
S5995 3 gang socket \$1.50

Guaranteed best make. Three windings of No. 18 Magnet wire. Has brass brackets for panel or base mounting. Guaranteed of money back.  
S2750 Cockaday coil \$1.50

Latest pattern. Genuine bakelite base. Fabnstock connectors, hard rubber composition knob, easiest to regulate. Size 5 1/2" long, 1" wide.  
S202 Neutralizing condenser .....\$ .40

Can be used for all tuned radio frequency circuits. Made for usual broadcast waves. Secondary has one center tap. Two genuine bakelite tubes.  
S6909 Neutro-transformer .....\$1.65

Get rid of tube noises due to vibration. Softest sponge rubber made. Size 2 1/2" x 3", 3/8" thick.  
S8989 Sponge-rubber cushions, each .....\$ .12

# RADIO SPECIALTY CO., 100 Park Place, New York City

Factories: Brooklyn, N. Y. Elkridge, Md.



# HIGH SCHOOL COURSE IN TWO YEARS

**YOU ARE BADLY** if you lack **HANDICAPPED** High School training. You cannot attain business or social prominence. You are barred from a successful business career, from the leading professions, from well-paid civil service jobs, from teaching and college entrance. In fact, employers of practically all worth-while positions demand High School training. You can't hope to succeed in the face of this handicap. But you can remove it. Let the American School help you.

**FIT YOURSELF FOR A BIG FUTURE** This course, which has been prepared by some of America's leading professors, will broaden your mind, and make you keen, alert and capable. It is complete, simplified and up-to-date. It covers all subjects given in a resident school and *meets all requirements* of a High School training. From the first lesson to the last you are carefully examined and coached.

**USE SPARE TIME ONLY** Most people *idle* away *fifty* hours a week. Probably you do. Use only one-fifth of your wasted hours for study and you can remove your present handicap within *two years*. You will enjoy the lessons and the knowledge you will gain will well repay the time spent in study.

Check and mail the coupon NOW for full particulars and Free Bulletin.

## American School

Dept. H626

Drexel Ave. and 58th St., Chicago

### American School

Dept. H626 Drexel Ave. & 58th St., Chicago

Send me full information on the subject checked and how you will help me win success.

- |                              |                            |
|------------------------------|----------------------------|
| .....Architect               | .....Lawyer                |
| .....Building Contractor     | .....Machine Shop Practice |
| .....Automobile Engineer     | .....Photoplay Writer      |
| .....Automobile Repairman    | .....Mechanical Engineer   |
| .....Civil Engineer          | .....Shop Superintendent   |
| .....Structural Engineer     | .....Employment Manager    |
| .....Business Manager        | .....Steam Engineer        |
| .....Cert. Public Accountant | .....Foremanship           |
| .....Accountant and Auditor  | .....Sanitary Engineer     |
| .....Bookkeeper              | .....Surveyor (& Mapping)  |
| .....Draftsman and Designer  | .....Telephone Engineer    |
| .....Electrical Engineer     | .....Telegraph Engineer    |
| .....Electric Light & Power  | .....High School Graduate  |
| .....General Education       | .....Fire Insurance Expert |
| .....Vocational Guidance     | .....Wireless Radio        |
| .....Business Law            | .....Undecided             |

Name.....

Address.....

## Doctor Hackensaw's Secrets

(Continued from page 500)

In a word, the car would not have traveled to Australia, but Australia would have traveled to the car. That is the principle on which my air express works.

"This cylinder that you see here is my car. It is loaded with merchandise for Australia and I intend to send it off this week."

"But," objected Silas, "didn't you once tell me that if a car left the earth, it would shoot off in a straight line at a thousand miles per hour in the same direction in which the earth was turning?"

"I did, Silas—I see I shall need another diagram. This circle is the earth and the arrow shows the direction of rotation.  $Y_1$  is the position of New York at the time the car is shot off and  $A_1$  is the position of Australia at the same time.  $C_1$  is the position of the car when it starts off on the straight tangent and  $C_2, C_3,$  and  $C_4$  are its position at intervals of six hours, since the car receives an impulse of one thousand miles per hour from the rotation of the earth. At the end of six hours the car has traveled 6,000 miles and will be at  $C_2$  while New York will be at  $Y_2$ , at the end of twelve hours the car would be at  $C_3$  and New York would be at  $A_2$ , while Australia would be at  $Y_3$ , the point from which the car was shot. Of course, long before this time the passenger would let in the earth's attraction so as to be pulled back to some new point X where the car would meet Australia. In fact, I should never let the car get more than about a thousand miles from the earth, as I believe the atmosphere there would be sufficiently rarefied."

"But you told me the car would also fly off at a tangent to the earth's orbit around the sun."

"True, but the tangent and the orbit itself would differ so slightly that I could easily make up for the difference by letting in a trifle more attraction from the earth."

"What is the object of that cylinder below the car?"

"That holds ballast to keep the car upright during the trip, for it is important that the screen should always be parallel to the earth's surface."

"Have you found anyone yet to send as a passenger?"

"Yes, I am going to send my fifteen-year-old office boy, Miggs, or I suppose I should say Tintageles Smith."

### CHAPTER 4

#### TINTAGELES SMITH

Tintageles Smith was Doctor Hackensaw's fifteen-year-old office boy. His father, plain John Smith, decided that his son should have a distinctive name. He succeeded, for there is probably no other Tintageles Smith in existence. Tintageles was born a scientist. At the age of twelve, he learned that yellow and blue combined to make green. So he took two small boys, chalked the nose of one with blue crayon and of the other with yellow crayon, then compelled the boys to rub noses together until a beautiful green resulted. At thirteen, Tintageles found a position, and with the first money he saved, he bought a revolver and started for the Wild West "to fight the Indians." His father caught him, however, before he had gone fifteen miles, and after a spiritual *séance* in the woodshed, Tintageles found standing more comfortable than sitting for a couple of days afterwards.

Finally, at fifteen, Doctor Hackensaw, hearing the story, decided that a lad with sufficient ambition and enterprise to emulate Buffalo Bill, would make a valuable assistant, and accordingly took him into his em-

ploy. He knew he had chosen wisely, when he learned later that Tintageles had paid a public stenographer to write him some love-letters addressed to the office; which letters the boy would apparently by accident display to his fellow-clerks, so that the words: "My own precious darling," or "Loads of kisses from your own little tootsie-wootsie Mabel," would drive them wild with envy.

Now it is a sign of culture to be able to pronounce the name Tintageles correctly. It rhymes with "sneeze" and the accent is on the second syllable, and the g is soft. As the office boys were not over-anxious to show off their culture, they nicknamed him "Miggs"—a most inappropriate name, for he *looked* as if his name was Tintageles.

Miggs had begged hard to be allowed to accompany the doctor on his trip to the moon. Doctor Hackensaw, on refusing, had promised to take him next time; and so it happened that Miggs was chosen to pilot the Negative Gravity car on its trip to Australia.

On the day appointed for the start, Miggs appeared sharp on time, all ready for the trip, as was evidenced by a copy of the "Nickel Library" and a pamphlet "How to Become a Detective" peeping from his pocket.

"Aren't you afraid to go alone on such a trip as this, my boy?" asked Silas Rockett, patronizingly.

"Nope!" responded the lad monosyllabically, with a curl of the lip. Without another word, he entered the car through a door in the top, closing the opening behind him.

In order to avoid all chance of accidents the machine was timed by clock-work to start and return automatically, the boy, however, having been taught how to modify his speed in case of necessity, by opening or closing the anti-gravitation screens.

At the appointed time the screens began automatically closing, and as they did so, the air above becoming lighter, the car was gradually sucked up until it was high in the air, the speed of the vehicle gradually increasing as more and more of the earth's attraction was shut off.

"I hope no harm comes to the boy!" said Silas, with some emotion, as he clambered down from the platform, followed by the Doctor.

Doctor Hackensaw heartily echoed the wish.

### CHAPTER 5

#### THE FLIGHT

Miggs was delighted as the car arose in the air and he felt the peculiar sensation of lightness due to the cutting off of some of the earth's attraction.

Although cautioned by the doctor not to "fool" with the instruments, his first care, when about twenty-five miles from the ground, was to close the screen completely, cutting off all attraction from the earth. This was delightful. Away he shot at a speed of about one thousand miles per hour. But to his surprise he was pushed against the western side of the car, for the atmosphere, though extremely rarefied at this height, offered an appreciable resistance to the car's progress, while there was no resistance to his own. However, he soon got beyond the limits where the air had any appreciable effect on the car's flight. Then the last vestige of his weight left him and he found he could swim about in the air or somersault around in the car in a way that would have made a circus acrobat green with envy.

To his surprise the sun and the stars



stood still, there would no longer be any morning, noon or evening for him, for the rotation of the earth no longer affected him. He, like the sun and stars, was now a heavenly body and viewed from the earth would seem to be revolving around it once every twenty-four hours, rising in the east and setting in the west.

For one hour Miggs allowed the car to rush through the heavens and then gradually checked its speed by letting in more and more of the earth's attraction, until after a journey of about a thousand miles, he brought the car to a complete stop, and then allowed it to fall toward the earth, its velocity increasing about thirty-two feet each second of the fall. When the speedometer indicated a speed of one hundred miles per hour toward the earth, Miggs regretfully shut off the gravitation again, allowing the car to continue downward by its acquired velocity. When he reached within a few miles of the earth's surface, the atmosphere became dense enough to retard the car considerably, and he was obliged to let in a little more attraction in order to get up speed again.

Unfortunately his interference with Doctor Hackensaw's nicely regulated adjustments resulted in upsetting the doctor's calculations, for the car landed in India instead of Australia, and Doctor Hackensaw, anxiously waiting for news of the car and its cargo, received the following characteristic dispatch by wireless:

"Mistake somewhere. Landed here in India instead of Australia. Car lost. Some fresh kids, fooling with it, closed the screens and the car went up like a flash. It must be near the moon now. One of the Hindoo kids went up with it. Please send good wad of money by cable. Mail bunch of detective stories to San Francisco, so I can have something to read on way home. Miggs."

### The Heavens In September

By ISABEL M. LEWIS, M. A.

(Continued from page 475)

Looking now a little to the southeast of Vega we come upon another star of special interest in Lyra. This is Beta Lyrae, which is known as an eclipsing variable star. In a period of twelve days and twenty-two hours, with the greatest regularity, this star goes through a cycle of light changes, due to the periodic eclipse of the brighter star by a faint companion revolving about it in a plane that is nearly in line with the earth. So once in each revolution the faint star must pass between us and its companion and shut off part of its light. The variation in the light of this star amounts to about three-fourths of a magnitude. There are a number of these eclipsing variable stars in the heavens, another well known star with light changes due to a similar cause being the Demon Star, Algol, in the constellation of Perseus now appearing above the northeastern horizon.

On a line from Beta Lyrae to the star nearest to it on the southeast known as Gamma Lyrae, and at about one-third of the distance from Beta is a wonderful object visible even in small telescopes, though seen at its best in the great reflectors. This is the Ring Nebula in Lyra consisting of a bright star within a ring of nebulous light. There are a number of similar objects in the heavens but this is the most beautiful one of this class and the only one visible in small telescopes. How this nebulous ring is formed is still very much of a mystery, though it is probable that it represents some form of emanations from the central star or a product of its gradual disintegration.

The Northern Cross in Cygnus now stretches diagonally across the zenith in our

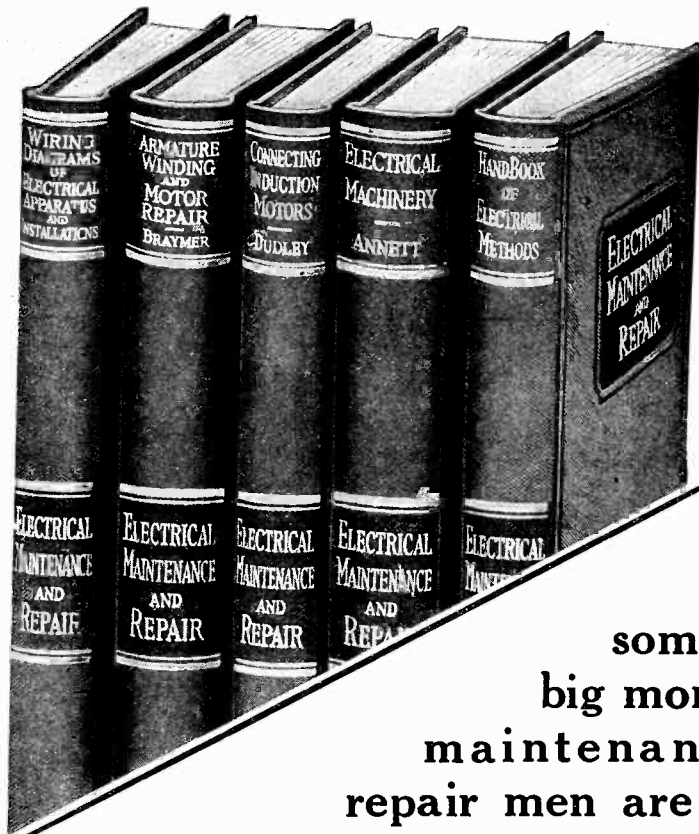

Go after some of the big money that maintenance and repair men are getting

Start this month—right now

THESE five great books have everything that the expert maintenance and repair man has to know. They tell you what to do, how to do it, and why. All of the information is given plainly so that you can understand every point that is made.

You can master these five books quickly—you can learn how to handle any kind of a maintenance or repair job—you can get the information that will make you an expert and bring you an expert's pay.

If you want a bigger and better job, here is the way to get it. If you want it before the year is up, now is the time to start.

## The Library of Electrical Maintenance and Repair

5 volumes—1736 pages—1818 illustrations—library binding

THESE five volumes contain the largest collection of practical methods for electrical repair and maintenance men ever put together in book form. Every one of the books is jammed from cover to cover with good, sound, how-to-do-it information—the kind you have to have when anything goes wrong.

They cover every phase of electrical repair and maintenance work from armature winding to the correction of brush troubles. And the treatment is always from the practical man's standpoint.

Fundamental laws and rules are discussed when necessary but there is no hard-to-understand theory or discussion of design. All of the material presented in these five books has been obtained from actual experiences. The library outlines the practical remedies that have been applied by repairmen all over the country in the solving of puzzling electrical problems.

Examine these books for 10 days free—no money down—only \$2.00 a month if you take them

WE want to place these books in your hands for 10 days' Free Examination. No expense to you—we pay all the charges—take all the risk. It is only by seeing them and actually trying them out in your work that you can judge the value of the books to you.

Fill in and mail the coupon. The books will be sent to you by return mail.

Name .....

Home Address .....

City and State .....

Employed By .....

Occupation ..... S.I. 9-1-24

McGraw-Hill Book Co., Inc.  
370 Seventh Ave., New York

FREE Examination Coupon

McGraw-Hill Book Co., Inc., 370 Seventh Ave., New York.

Gentlemen: Send me the LIBRARY OF ELECTRICAL MAINTENANCE AND REPAIR (shipping charges prepaid), for 10 days' free examination. If satisfactory I will send \$2.00 in ten days and \$2 per month until the special price of \$14.00 has been paid. If not wanted, I will write you for return shipping instructions. (Write plainly and fill in all lines.)



# Become a Commercial Electrical Engineer

In 1 Year at this Famous School

No calling offers such unbounded opportunities to the modern ambitious young man as that of Commercial Electrical Engineering. It is for this reason that this great school has organized a special course in Commercial Electrical Engineering that may be completed in one year.

Within recent years the Electrical field has become so wide and diversified that there has sprung up a great demand for Electrically trained business men, consulting and efficiency engineers, men who can handle Commercial and Engineering problems. This special course offers a thorough, condensed, and very practical Electrical Engineering training especially adapted to high-school graduates.

Here, you will also find any other kind of Electrical education which you might desire. School of Engineering is the largest Institution in America devoted exclusively to the teaching of Electricity and allied subjects.

## Electrical Engineering With B.S. Degree in 3 Years

A faculty of specialists is leading hundreds of ambitious young men to a sure and substantial success. Why not you? If you lack some of the educational requirements, you can make them up as you go along. This gives you the opportunity of becoming an electrical engineer in the shortest possible time.

## Electrotechnics

Only one or two years of this course, and you are a fully trained electrotechnician—prepared to fill such positions as general plant superintendent, director of construction, superintendent of maintenance, chief draftsman, etc. This course will equip you for a position between that of an electrical engineer and that of an electrician, which is a well paying position, leading to higher executive work. A grade school diploma or its equivalent admits you without examination. New terms open every three months.

## Practical Electricity

This complete six months' electrical course teaches you house, factory and theatre wiring, testing and meter work, A.C. and D.C. motor installation, repairing and maintenance, including shop work in A.C. and D.C. armature winding and all necessary mathematics.

A three months' course in A.C. and D.C. armature winding, or in light and motor wiring.

## Automotive Electricity

Electrical specialists who instinctively diagnose and locate automotive electrical troubles command high positions and are well paid. Specialize in starting, lighting, ignition and storage batteries, and command a big job at a big salary! There are millions of automobiles, motor trucks, tractors, motorcycles, aircraft, farm lighting plants, but few real experts who can put their fingers right on electrical troubles. Specialists teach this course on actual standard equipment—three months day school, or through home study. Come any time and we will put you in the thick of the work.

# SCHOOL OF ENGINEERING of Milwaukee

Founded 1905

School of Engineering of Milwaukee,  
S.1.924A, 415 Marshall Street, Milwaukee, Wis.

Without obligating me in any way, please mail free illustrated book and further particulars on the course I have marked with an X.

- |                                       |                                   |
|---------------------------------------|-----------------------------------|
| ....Commercial Electrical Engineering | Practical Electricity             |
| ....Electrical Engineering            | ....6 mo. complete course         |
| ....B.S. Degree                       | ....3 mo. Armature Winding course |
| ....Electrotechnics                   | ....3 mo. Light and Motor Wiring  |
| ....Drafting                          |                                   |
| ....Automotive Electricity            |                                   |

Name..... Age.....  
Street..... City..... State.....  
Education .....

latitudes, a beautiful object in the midst of the star clouds of the Milky Way with the first magnitude star, Deneb, one of the twenty brightest in the heavens, at the head of the cross and the finest of double stars, Albireo, at its foot.

Altair, the first magnitude star in Aquila, is now nearly due south. It also is one of our near stellar neighbors, somewhat nearer than Vega, for its distance is placed at somewhere between fifteen and twenty light years. If a line is drawn from Albireo at the foot of the Northern Cross to Altair and continued as far again it will bring us to another interesting object, the wide naked-eye double star Alpha in the constellation of Capricornus, which star can be easily distinguished as a double star without the aid of a telescope. Just a little to the south of Alpha Capricorni we find the star Beta Capricorni, which is somewhat brighter than Alpha. Capricornus is an inconspicuous constellation containing no stars brighter than the third magnitude, but the configuration formed by the wide double Alpha and the nearby Beta will aid in identifying this constellation which once contained the point marking the farthest southern excursions of the sun, a spot now found in Sagittarius, the next of the zodiacal groups on the west.

To the east of Capricornus in the constellation of Aquarius, The Water-Bearer, we will now find Mars in all of its glory, the most magnificent object in view, even more resplendent than Jupiter, which is still visible in the western sky. Mars made its

nearest approach to the earth on the twenty-third of August, but on September 1st it is at a distance of 35,200,000 miles, only about half a million miles more distant than it was on the twenty-third, and for the greater part of this month it will remain nearer to the earth than it has been for a number of years. By the 30th of September its distance will have increased to 43,650,000 miles, which is less than its distance at an average opposition.

The brightness of Mars will show a noticeable decrease during the month of September. On the first of the month it will be more than twice as bright as Jupiter, but by the thirtieth of the month the two planets will be almost equally bright, with Mars a little the brighter of the two.

Those interested in studying the surface markings of the ruddy planet will probably be particularly busy this month, while the planet can still be seen to the best advantage. It is probable that observations will also be made with powerful telescopes of the two tiny moons of Mars, Deimos and Phobos, each of which is less than twenty miles in diameter and which were first discovered by Asaph Hall, Sr., with the twenty-six inch equatorial of the U. S. Naval Observatory at the favorable opposition of August, 1877. So small and faint are these two satellites of Mars and so close to the brilliant planet that they are only observable with the most powerful telescopes and it is a considerable astronomical feat to detect them.

## Answers to Scientific Problems

(Continued from page 473)

### THE FLOATING BEAM

Two forces may be considered as acting upon any floating body. One, directed downward and due to the weight of the body, may be considered as acting at the center of gravity; the other, due to the buoyant force of the liquid, is directed upward from the center of buoyancy. If the two centers are not in a vertical line the forces tend to rotate the body around until the centers of gravity and buoyancy are directly one above the other. Furthermore, since the buoyant force tends to raise the center of buoyancy it is evident that the body is in its most stable position when the center of buoyancy is highest and its center of gravity lowest. Fig. 1 represents an unstable position because the center of buoyancy is not directly below the center of gravity. Of Figs. 2 and 3 the former represents the more stable position, for the center of buoyancy is not only directly below the center of gravity but it is also higher up.

### THE BELL CIRCUIT

The correct hook-up is shown herewith.

### THE PUZZLE PICTURE

The following inconsistent or erroneous situations are represented:

1. In the latitude of New York shadows do not point south, nor is a rainbow visible in the north.
2. Of course, New York is not 500 miles west of any coast.
3. The rainbow should be represented in the form of a circle, not of an ellipse; the clothesline in the form of a catenary, not of a circle; the stream of water from the hose in the form of a parabola instead of the arc of a circle.
4. Both man and dog are walking in an unnatural manner.

### DESCENT FROM ONE PLANE TO ANOTHER

When an object falls or rolls from one horizontal plane to another the potential

energy or energy of position which the body has on the upper plane becomes converted into kinetic energy or energy of motion on reaching the lower plane. The potential energy is measured by the product of the weight of the object into the vertical distance through which it can fall or roll. The kinetic energy is proportional to the weight of the object and the square of the velocity

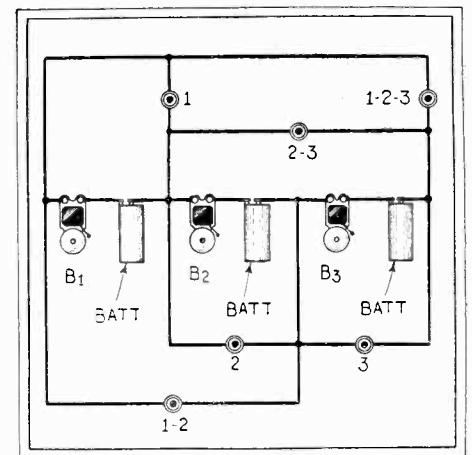

Solution of the electric bell ringing problem.

with which it moves. If no energy is lost, the potential energy equals the kinetic energy and the relation may be expressed by the

$$W s = \frac{1}{2} W v^2$$

equation  $W s = \frac{1}{2} W v^2$  in which W represents

the weight of the object, s the distance between the planes, v the velocity on reaching the lower plane, and g the acceleration due to gravity. The left hand member  $W s$  represents the potential energy of the body on the upper plane and the right hand member  $\frac{1}{2} W v^2$  the kinetic energy on reaching the

2g

lower plane. Solving for  $V^2$ , we see that  $V^2=2gs$  and hence is constant for all bodies regardless of their weight. Of course, in practice some energy would be lost in friction and the bodies losing the least energy by friction would reach the lower plane with the highest velocity. It should be noted that it has not been said that all bodies would reach the lower plane in the same time, but theoretically at least or neglecting friction all bodies should reach the lower plane with the same velocity. The body on the cycloid will descend the quickest. The cycloid is termed the brachistochrone, as it is the curve of quickest descent. Also, it will take a body the same time to roll down the entire curve, or to go only a part of the descent if always ending its course at the bottom.

**THE GRAVITATIVE WHEEL**

This system will not work because of the opposing pressure that is produced in the region where the casing bears against the lower wheel. The action is very much like wringing a garden hose through the wringer when the hose is full of water under pressure. It can be shown that the moment due to this back pressure exactly equals the moment due to the weight of the water in the casing. Hence the wheel would not start turning even if friction were reduced to a minimum.

**THE SINKING BALL**

As the ball rotates it tends to drag some of the water around with it. This water will tend to increase the pressure on the right hand side which is moving downward and decrease the pressure on the left where the edge is moving upward. Hence the ball will be deflected toward the left slightly as it sinks.

**PLANK ON ICE**

If an object is held stationary by three or more non-parallel forces the direction

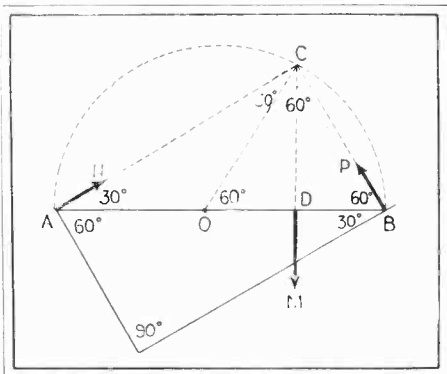

Relation of forces in plank on ice problem.

lines of these forces must intersect in a common point. In our problem the downward force DM of the boy's weight is balanced by the reaction forces AN and BP perpendicular to the walls of the ravine. For equilibrium, then, the three direction lines AC, DC, and BC must intersect in a common point, C. From the figure it is evident that  $BC=OB=OA=\frac{1}{2} AB$ . and, by similar triangles  $DB=\frac{1}{2} CB=\frac{1}{4} AB$ . Hence if the plank is not to slip either way the boy must stand one-fourth of the length of the plank from the end B.

**THE ICEBOAT**

Let SS represent the sail of the boat, AO the direction and magnitude of the force of the wind against the sail. Then BO represents the component of this force perpendicular to the sail and CO the useful component that moves the boat forward. Now, since the boat is not sailing directly away from the wind it is certain that no matter how



**THE EXECUTIVE**

Every executive is at some time called upon to make decisions which involve applied Chemistry. If he does not know Chemistry, he must rely entirely upon his factory chemists or high priced consultants. A knowledge of Chemistry, easily gained through our Course, would strengthen your position greatly and save you thousands of dollars.



**THE BUSINESS MAN**

Better buying and bigger sales are the rewards of the man who understands Chemistry. Manufacturers, buyers, salesmen, advertising men, cost accountants and clerks can all benefit by learning Chemistry. Our course teaches you in the shortest and most practical way.



**THE PROFESSIONAL MAN**

Every professional man needs a working knowledge of Chemistry whether he is practicing law, medicine, engineering, dentistry, or any other calling. Too often he finds this all important science was neglected in his earlier training. Our course removes the handicap. Most important, it gives you information in a form that can be readily used.



**THE WORKER**

Workers in any industry can raise their own wages by learning Chemistry, for every industry is based on Chemistry. Write and tell us what your work is and we will show you how Chemistry can fatten your pay envelope.

# CHEMISTRY

## Insures Your Climb to Success

*No matter what your vocation you can increase your Proficiency and earn bigger pay by a thorough training in Chemistry*

To be successful today is to know Chemistry! Every line of business, every branch of industry depends upon Chemistry in some form. You may not realize it, but your own proficiency in whatever work you are doing would be increased by a knowledge of Chemistry. In many lines such knowledge is absolutely essential. In others it is a guarantee of promotion and more money.

It is no longer necessary to enter college in order to learn this fascinating science. Our Home Study Course trains you just as thoroughly, and with the same assurance of success, as those who took the longer way. And our methods are so simple that we can teach you no matter how little previous education you may have had. Many of our graduates now hold responsible positions or have materially increased their incomes from private enterprises as a result of taking our course. Hundreds of letters from students testifying to the benefits they have derived from our training are here for your inspection.

Remember that you do not need to study Chemistry with the idea of actually practicing as a chemist, although a great many of our students are taking our course with this object in view. If you want to know more about what Chemistry will do for you, if you want to know what our home study course offers, sign and mail the coupon today for FREE BOOK "Opportunities for Chemists."

**DR. T. O'CONNOR SLOANE Will Teach You Practical Chemistry In Your Own Home**

The Chemical Institute of New York, of which Dr. T. O'Connor Sloane is Educational Director, was founded to fill the need of ambitious, far-sighted men who realize and recognize the splendid future Chemistry offers them, but who cannot spare either the time or the money to attend college. Dr. Sloane, a foremost authority on Chemistry, will teach you and will give you all the individual help you require. He will personally go over your papers, correct them, point out your faults and teach you in a practical and interesting way. No special education needed except the ability to read and write English. One student has characterized our lessons as "The course that takes the mystery out of Chemistry."

### Easy Monthly Payments

You do not have to have even the small price of the course to start. You can pay for it in small monthly amounts—so moderate that you won't feel them. The cost is low, and includes everything, even the Laboratory Equipment—there are no extras to buy. Our plan of easy monthly payments places a chemical education within the reach of everyone.

**Laboratory Equipment Given To Every Student Without Additional Charge**

We give to every student without additional charge his chemical equipment, including forty-nine pieces of laboratory apparatus and supplies, and forty different chemicals and reagents. These comprise the apparatus and chemicals used for the experimental work of the course.

### Special 30-Day Offer

For a short period we are making a special offer that will be worth your while to take advantage of. Write for particulars, using the coupon below or simply a postal card. This will not obligate you in the least. Do not wait until tomorrow. Send the coupon now while you think of it.

**The CHEMICAL INSTITUTE of New York, Inc.**

Home Extension Division 9

66-S W. Broadway, New York City

**Sign and Mail this Coupon for FREE BOOK**

CHEMICAL INSTITUTE OF NEW YORK, Inc.  
Home Extension Division 9  
66-S—West Broadway, New York City.

Please send me at once without any obligation on my part, your Free Book "Opportunities for Chemists," and full particulars about the Laboratory Equipment furnished to every student. Also please tell me about your plan of payment and your special 30 day offer.

NAME .....

ADDRESS .....

CITY .....

STATE .....

S. & I. 9-24

# BUILDING TRADES NEED MEN!

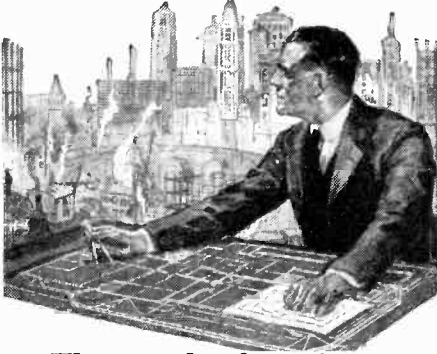

Thousands of good jobs at good salaries

THE business tide has turned! And the building trades are leading the way back to prosperity! Government experts estimate that two to four billion dollars will be spent for building construction this year.

To-day the most vital need of this great building program is men—trained men—men who can step right in and do the skilled work that building construction requires.

There is a simple, easy, fascinating way by which you can prepare for a good position, at a good salary. You can do it right at home, in spare time, no matter where you live, through the International Correspondence Schools.

Will we ask is the chance to prove it. That's fair, isn't it? Then mark and mail the coupon printed below and get the full story of what the I. C. S. can do for you.

**TEAR OUT HERE**

**INTERNATIONAL CORRESPONDENCE SCHOOLS**  
Box 6165-D, Scranton, Penna.

Without cost or obligation, please tell me how I can qualify for the position or the subject before which I have marked an X in the list below:

**TECHNICAL AND INDUSTRIAL COURSES**

- |  |   |
|--|---|
| <input type="checkbox"/> Architect               | <input type="checkbox"/> Surveying and Mapping    |
| <input type="checkbox"/> Architectural Draftsman | <input type="checkbox"/> Gas Engine Operating     |
| <input type="checkbox"/> Architects' Blue Prints | <input type="checkbox"/> Automobile Work          |
| <input type="checkbox"/> Building Foreman        | <input type="checkbox"/> Airplane Engines         |
| <input type="checkbox"/> Concrete Builder        | <input type="checkbox"/> Plumber and Steam Fitter |
| <input type="checkbox"/> Contractor and Builder  | <input type="checkbox"/> Plumbing Inspector       |
| <input type="checkbox"/> Structural Draftsman    | <input type="checkbox"/> Foreman Plumber          |
| <input type="checkbox"/> Structural Engineer     | <input type="checkbox"/> Heating and Ventilation  |
| <input type="checkbox"/> Electrician             | <input type="checkbox"/> Sheet Metal Worker       |
| <input type="checkbox"/> Electrical Engineer     | <input type="checkbox"/> Steam Engineer           |
| <input type="checkbox"/> Electrical Contractor   | <input type="checkbox"/> Railroad Positions       |
| <input type="checkbox"/> Electric Wiring         | <input type="checkbox"/> Chemistry                |
| <input type="checkbox"/> Mechanical Engineer     | <input type="checkbox"/> Pharmacy                 |
| <input type="checkbox"/> Mechanical Draftsman    | <input type="checkbox"/> Metallurgy               |
| <input type="checkbox"/> Machine Shop Practice   | <input type="checkbox"/> Mining Engineer          |
| <input type="checkbox"/> Toolmaker               | <input type="checkbox"/> Navigation               |
| <input type="checkbox"/> Civil Engineering       | <input type="checkbox"/> Mathematics              |
|  | <input type="checkbox"/> Radio                    |

**BUSINESS TRAINING COURSES**

- |  |   |
|--|---|
| <input type="checkbox"/> Business Management     | <input type="checkbox"/> Salesmanship           |
| <input type="checkbox"/> Industrial Management   | <input type="checkbox"/> Advertising            |
| <input type="checkbox"/> Personnel Organization  | <input type="checkbox"/> Better Letters         |
| <input type="checkbox"/> Traffic Management      | <input type="checkbox"/> Foreign Trade          |
| <input type="checkbox"/> Business Law            | <input type="checkbox"/> Show Card Lettering    |
| <input type="checkbox"/> Banking and Banking Law | <input type="checkbox"/> Stenography and Typing |
| <input type="checkbox"/> Accounting              | <input type="checkbox"/> Teacher                |
| <input type="checkbox"/> (Including C.P.A.)      | <input type="checkbox"/> Civil Service          |
| <input type="checkbox"/> Nicholson Cost          | <input type="checkbox"/> Railway Mail Clerk     |
| <input type="checkbox"/> Accounting              | <input type="checkbox"/> Common School Subjects |
| <input type="checkbox"/> Bookkeeping             | <input type="checkbox"/> High School Subjects   |
| <input type="checkbox"/> Business English        | <input type="checkbox"/> Illustrating           |
| <input type="checkbox"/> Private Secretary       | <input type="checkbox"/> Cartooning             |
| <input type="checkbox"/> Business Spanish        | <input type="checkbox"/> French                 |

Name.....  
Street.....  
Address.....  
City..... State.....

Occupation.....  
Persons residing in Canada should send this coupon to the International Correspondence Schools Canadian, Limited, Montreal, Canada.



**Save \$38.80**

Take advantage of the great saving we offer on the genuine, world-famous, ball-bearing, long-wearing L. C. Smith Typewriter. Late model machines, standard size, up-to-date in every way, at remarkably low prices.

**SEND NO MONEY** **LOW PRICES**  
**A YEAR TO PAY EASY TERMS**  
**Guaranteed Five Years**

We do the most perfect and highest class job of rebuilding known to the typewriter industry. Our machines do perfect work and last for years and years. Just like new. The L. C. Smith is the easiest machine to operate and you can easily type over letters. Complete lessons on typewriting, also our 5 Year Guarantee with every machine. Send today for Free Booklet of Valuable Typewriter Information, Big Catalog and our Special Offer.

**SMITH TYPEWRITER SALES CO.**  
363-360 East Grand Avenue Chicago, Illinois

**B-METAL**  
B-METAL Crystals cannot be beat for Rest Sets. Order them from your dealer now.  
**B-METAL REFINING CO.**  
11th floor  
525 Woodward Ave.  
Detroit, Mich.

fast it goes the wind will always be producing pressure against the sail and hence will tend to constantly increase its velocity. Then if friction is not too great there is no reason why the speed of the boat cannot considerably exceed that of the wind.

**THE AVIATOR'S RACE**

At first it may seem that neither aviator has an advantage over the other on account of the wind, for will not the wind help and hinder aviator B by equal amounts since it opposes him over the same distance that it helps him? To answer this let us suppose the wind blows with sufficient velocity to prevent the return of the aviator against it. Then he could go very quickly with the wind but would never be able to return and complete his trip. Thus we see that the wind really hinders aviator B more than it helps him, for it hinders him for a longer time than it helps.

## Book Review

**VOICES FROM ANOTHER WORLD.**

By F. Gurtis. Nom de plume for Willabald Frank. Translated by Lilian A. Clare. Stiff cloth covers, 5 3/4" x 8 1/2", 243 pages. Published by Dodd, Mead and Co., New York City. Price, \$3.00.

With the words of Arthur Schopenhauer, the author introduces this work, and we must agree with the introduction that there does not seem to be any definite purpose for the work. The assumption is made that all would-be communications with the spiritual world are actually produced by the subconscious mind. This is not a new theory to be sure, inasmuch as it has received considerable prominence during recent years. The author found an instrument with which communications with the spirit world were to be obtained. This machine was similar to the Pantograph. The investigators would sit around it and place their finger tips on the ends of the machine, and a point would then stop at letters in the alphabet progressively arranged in a square chart. The machine never did work for the author and his wife, but would only give results when other people were present in the séance with the author. The "Psycho-graph," as that is the name given to the machine, did not to this extent differ with our ouija board, but its appearance was different, although its manner of operation was much the same.

After a short introductory discussion, the greater part of the work takes up the history of records, and is in fact a transcript of questions and answers produced during a series of séances with various persons who were requested to sit in. Many places, names, locations, and incidents were recalled which we thought to be entirely unknown to any of those sitting in, and on being checked up in an encyclopedia were found to be definite occurrences which were invariably correct. In parts the work resembles a farce; in other places it is crude, and in still other portions of this work, vulgarity is predominant. As an attempt at a scientific book it falls far short of the mark. Its greatest redeeming feature is the description of the Psycho-graph, which description if followed carefully might enable any other individual to construct a machine of a similar type and play with it. Drawing the same conclusion that the author does, namely, that the answering of the questions is the working of the subconscious mind, we could question the character of some of the individuals who assisted in forming the records which occupied at least two-thirds of the work, but being cheerful law-abiding citizens, we will not do so.—K.

**LIGHT AND WORK.** By M. Luckiesh. Hard covers, 6" x 9", fully illustrated, 296 pages. Published by D. Van Nostrand Co., New York City. Price \$4.00 net.

Dr. Luckiesh, following his usual course of treating a subject which might be quite obtruse, makes it thoroughly interesting and has produced a book which can be read consecutively with great enlightenment and pleasure. A great deal is known about illumination, but it is really pathetic to see how little use is made of that knowledge. A slight difference in the color of a wall will impair the illumination of a room greatly, and impairing illumination means running up the bills for light supply. The writer has sat in a room with varnished pitch pine walls with a strong kerosene lamp by his side, and found that reading could not be done in any comfort. It seemed that in the room all the lamp could do was to make a hole in the darkness, and yet when people are decorating their houses, they remorselessly put on paint which impairs the illumination. The practical points are brought out toward

**FREE**  
To Each Purchaser of a **World Battery**

A 24-Volt "B" Storage Battery positively given FREE with each purchase of a WORLD "A" Storage Battery. The WORLD BATTERY is famous for its guaranteed quality and service. Backed by years of Successful Manufacture and Thousands of Satisfied Users. You save 60%.

**Prices That Save and Satisfy**

Auto Batteries		Radio Batteries	
6-Volt, 11 Plate	\$12.25	6-Volt, 80 Amps.	\$10.00
6-Volt, 13 Plate	14.25	6-Volt, 100 Amps.	12.50
12-Volt, 7 Plate	17.00	6-Volt, 120 Amps.	14.50
		6-Volt, 140 Amps.	16.00

Shipment Express C. O. D. subject to examination. 6 per cent discount for cash on full with order.

**2-Yr. Guarantee Bond in Writing With Each World Storage Battery**

proves satisfactory World performance. Mail this ad with your name and address—we will ship battery next order is received; and give you your choice of "B" Storage Battery of a handsome nickel finish Auto Spotlite, FREE. Write TODAY.

**WORLD BATTERY COMPANY**

1219 So. Wabash Ave. Dept. 10, CHICAGO, ILL.

This FREE "B" Storage Battery takes the place of dry cell "B" batteries. Can be recharged and will last indefinitely. To be sold retail for \$6.00. It is the only battery of its kind equipped with solid rubber case—and insurance against acid and leakage. Take advantage of this remarkable introductory offer NOW. (To those who prefer it, we will send FREE a handsome nickel finish Auto Spotlite, instead of the "B" Battery. Be sure to specify which is wanted.)

**GIVEN FREE**

To introduce this new and superior World "B" Storage Battery to the Public.



## FORDS-34 Miles

on Gallon of Gasoline with Air Friction Carburetor

We guarantee all other cars nearly double present mileage, power and flexibility. Models for any car, truck, tractor, marine or stationary engine. Makes old cars better than new. See our mileage guarantee.

Ford, 34 mi. | Chevrolet, 32 mi. | Dodge, 28 mi. | Maxwell, 30 mi. | Overland, 32 mi. | Oakland, 24 mi.

Mileage guarantee on any other car sent on request.

**SENT ON 30 DAY'S FREE TRIAL**

You can drive any car in heaviest traffic without shifting gears. Starts off on high in any weather without priming or heating—No jerking or choking. Agents Wanted.

**AIR-FRICTION CARBURETOR COMPANY**

1219 Raymond Building Dayton, Ohio, U. S. A.

**Make \$75.00 a Week and up**

Make \$75.00 a week and up, selling our fine made-to-measure, all-wool suits at \$31.50 retail, direct to wearer. Biggest values—positively sell on sight. Biggest commissions paid in advance. We attend to delivery and collections. 6 x 9 sweat samples—over 100 styles all one price—furnished FREE. Write at once.

**W. Z. GIBSON, Inc.** Merchant Tailor  
161 W. Harrison St., Dept. J-90, CHICAGO

6 Shots  
**1924 MODEL**  
Side Swing Cylinder Revolver made of Bilbao blue steel. Send for this accurate, dependable and powerful gun, with automatic hammer safety and inspection plate. Send No Money—Pay Free Catalog  
\$14.75  
\$2.20 or 33 Cal.  
NEW YORK IMPORTERS CO.  
Dept. 454M, 200 Broadway, New York City

**Fortune Telling Globe!** The GENUINE CRYSTAL ORACLE answers every question—Love, Marriage, Money, Luck! Mystifying, thrilling, fascinating game. \$4.00 in 168-page Book on Divination by Crystal Dreams, etc.; also Book How to Converse with Spirits. Send 20c for postage. Pay the balance (\$2.25) when delivered.  
**PARK PUB. CO.**  
Park Row Bldg., New York Dept. SC  
**\$2.45**

**ELECTRICITY LEARN AT HOME**  
Send for catalog which tells how Burgess Home Training enables men and boys to get good jobs and keep them.  
**BURGESS ELECTRICAL SCHOOL**  
Chicago  
Dept. 9, 745 East 42nd Street

the end of the relation of visibility and safety where it appears how many accidents are occasioned by improper and inadequate lighting. It is claimed that about twenty per cent of all traffic or industrial accidents are due to this one cause. Even color blindness is spoken of, and for stopping car signals red and blue-green are recommended, in that not one in one hundred thousand persons would have trouble in distinguishing these colors. At the end of the book is a list of Dr. Luckiesh's other works, and while these appear as advertisements, we strongly advise the reader to read them through, and he will then realize why we say that Prof. Luckiesh has the rare faculty of awakening human interest in difficult scientific subjects.

**HOUSEPAINTING.** By Alvah Horton Sabine, M.S. Hard covers, 5" x 7½", 160 pages. Published by John Wiley & Sons, Inc., New York City. Price \$3.50 net.

Dr. Sabin has a number of books on paint and varnish to his credit, and here we have one addressed to the householder. It is quite interesting reading and the high cost of labor has had the effect of inducing many householders to do much work about the house which they otherwise would not dream of attempting. Very interesting features of this work are those where the author goes into the subject of proportions of oil for mixing paints, the square feet which a definite amount will cover, both in regard to old or new wood, and all other material which comes under the title of the book. Brushes receive considerable space, which is eminently proper. White lead poisoning is included. The aggravating subject to the amateur of glazing is treated of. We are glad to see that he recommends bedding window glass in putty when putting it into sashes. Removal of old paint is described and the book has an aspect of practicability and efficiency throughout.

**ELEMENTS OF WATER BACTERIOLOGY.** By Samuel Cate Prescott. Hard covers, 6" x 9¼", illustrated, 205 pages. Published by John Wiley & Sons, New York City. Price \$2.50 net.

It has taken mankind many long ages to wake up to the effects of insects and low forms of life upon his system. This very elaborate treatise covers the subject of the bacilli found in water, of intestinal bacteria, of the significance of the colon group in water, and the bacteriological relations of sewers. It took a long while before Koch's discovery of the relation of the mosquito to malaria was taken with even a small degree of seriousness, and the wonderful work done on the Isthmus of Panama by Dr. Gorgas in the elimination of yellow fever, put the seal of approval upon Koch's work. Today the mosquito is being scientifically exterminated and malaria is disappearing from what were infected regions along with the disturbing insects. An interesting chapter in this book covers the examination of shell fish for bacteria, for it is realized that oysters may produce typhoid fever if they have been propagated in contaminated water. A most valuable portion of the work is the twenty-nine page bibliography of the subject. A full subject index is given.

**THE A B C OF ATOMS.** By Bertrand Russell, F. R. S. Hard covers, 5¼" x 7¾", 162 pages. Published by E. P. Dutton & Co., New York City. Price \$2.00.

Mr. Russell's clear, concise style has been used, in this volume, to explain the most abstruse of the scientific theories. The whole subject of atoms is extremely complicated, and unless the writer has a very clear conception of the subject itself, and has the ability to state clearly and simply what he thinks, the result will be pretty much of a mess as far as the layman is concerned. However, Mr. Russell reviews the subject in such a way that the man in the street will not be required to read many paragraphs more than once in order to get the gist of the subject, and have a fairly complete understanding of the points which Mr. Russell wishes to bring out. The book is divided in such a way as to make the following of the subject very easy. From the discussion of the Periodic Law, he passes on to a discussion of electrons and nuclei. Then he has an illuminating chapter on the spectrum. The theory of quanta, X-ray activities and the structure of nuclei are also dealt with. Then there is a couple of chapters given to the new physics and the wave theory of light, and a cursory discussion on the Theory of Relativity. The mathematics of the whole volume that is, as much of it as it is possible to omit from the actual discussion, is given in an appendix where a complete mathematical discussion on Bohr's Theory of the hydrogen spectrum is to be found.

**THE MIND IN ACTION.** A Study of Human Interests. By George H. Green. Hard covers, 5½" x 8", 223 pages. Published by G. P. Putnam's Sons, New York City. Price \$2.00.

This volume is another of those books which have been coming from the presses in a more or more  
(Continued on page 520)

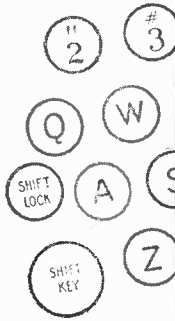

## Easy to Learn ~ Easy to Operate

The Remington Portable is easy to learn because it has the one and only standard keyboard, with four rows of keys and no shifting for figures—exactly like the big machines—the keyboard universally adopted by business as the best.

It is easy to operate because it is the most complete portable typewriter, with every feature common to the larger machines. So light it can be carried anywhere, so convenient it can be used anywhere, and so small that it fits in a case only four inches high. It is compact, strong and durable. And its work is beautiful—always.

Remington branches and dealers everywhere sell the Remington Portable. Use it as you pay, if you wish.

Ask for a demonstration, or write for illustrated "For You—For Everybody". Address Department 14.

*We believe we make the best typewriter ribbon in the world, and its name is PARAGON*

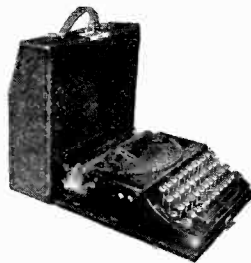

**Remington Typewriter Company**  
374 Broadway, New York—Branches Everywhere  
Remington Typewriter Company of Canada, Limited;  
Main Office, 68 King Street West, Toronto

# REMINGTON PORTABLE

THE RECOGNIZED LEADER—IN SALES AND POPULARITY

# U.S. PATENTS



**SEND FOR THIS FORM**

## Don't Lose Your Rights

Before disclosing your invention to anyone send for blank form "Evidence of Conception" to be signed and witnessed. A sample form together with printed instructions will show you just how to work up your evidence and establish your rights before filing application for patent. As registered patent attorneys we represent hundreds of inventors all over the U. S. and Canada in the advancement of inventions. Our schedule of fees will be found reasonable. The form "Evidence of Conception" sample, instructions relating to obtaining of patent and schedule of fees sent upon request. Ask for them,—a post card will do.



Registered Patent Attorneys in U.S. and Canada  
255 Ouray Bldg., Washington, D. C.  
"Originators of form Evidence of Conception"

# PATENTS

Hand books on Patents, Trade Marks, etc. sent free. Our 78 years of experience, efficient service, and fair dealing assure fullest value and protection to the applicant. The Scientific American should be read by all inventors.

## MUNN & CO.

618 Woolworth Building, New York

Scientific American Building, Washington, D. C.  
Tower Bldg. Chicago, Ill.  
Hobart Bldg., 582 Market St., San Francisco, Cal.  
Van Nuys Building, Los Angeles, Cal.



In this Department we publish such matter as is of interest to inventors and particularly to those who are in doubt as to certain Patent Phases. Regular inquiries addressed to "Patent Advice" cannot be answered by mail free of charge. Such inquiries are published here for the benefit of all readers. If the idea is thought to be of importance, we make it a rule not to divulge all details, in order to protect the inventor as far as it is possible to do so.

Should advice be desired by mail a nominal charge of \$1.00 is made for each question. Sketches and descriptions must be clear and explicit. Only one side of sheet should be written on.

**NOTE:**—Before mailing your letter to this department, see to it that your name and address are upon the letter and envelope as well. Many letters are returned to us because either the name of the inquirer or his address is incorrectly given.

### PENCIL SHARPENER PROTRACTOR AND AND PHONE RECEIVER HOLDER

(821) Louis M. Rawlins, Jr., Baltimore, Md., asks whether he should patent the protractor illustrated herewith; a bracket to hold a telephone receiver while talking into the phone leaving one arm free and an automatic electrical pencil sharpener.

A. We are of the opinion that the automatic protractor which you have designed is non-patentable, but in order to definitely determine this you should have a patent search made by a

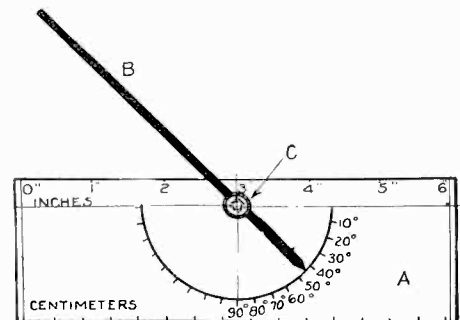

The protractor illustrated above is suggested for patenting. The opinion is given in the text.

reliable attorney. We frankly believe that the possibilities of this protractor are very limited, and do not think that a patent upon the same would be of any value.

This magazine published a photograph of an automatic arm to hold the receiver of a telephone while talking into the same. There are about forty such on the market. Most telephone companies do not permit the use of such attachments on their telephone. This suggestion is not new.

An automatic electric pencil sharpener is a rather old idea. It is likewise expensive. We also published an article on how one reader converted a regular pencil sharpener into an automatic electric one by using a motor and a telephone jack to close the circuit. This appeared over a year ago.

We do not advise applying for a patent upon any of the three ideas submitted by you.

### NON-MAGNETIC STEEL

(822) L. Bacevitz, Elizabeth, N. J., suggests that ships and ship parts be of non-magnetic steel. In this way the compass would not be affected by the presence of iron or steel in the ship's make-up. He asks if a patent on a process for producing non-magnetic steel would be of value.

A. There are many steels which are non-magnetic or very slightly so. For instance, ferromanganese is but slightly magnetic; nickel steel the same, and the steel alloyed with other materials is sometimes but slightly magnetic.

On board ship where the metal of the vessel causes changes in the magnetic compass, such steel could be substituted or corrective measures (such as are used at present) could be employed. The gyro-compass, however, is doing away with the effect which steel vessels produce.

Undoubtedly a patent might protect a process of producing such a substance, but what advantage such a patent would have we are not prepared to state. We doubt if it would be very great.

### MARKETING

(823) H. Bidwell, Minneapolis, Minn., asks how he can market a collar clip ready for distribution.

A. It is very difficult to make suggestions on the collar clip, which you are placing upon the market. There are thousands of ways of marketing such an invention. For instance, you could advertise for salesmen to handle this product, and then create agencies throughout the country, or you could offer the goods to reputable houses on consignment to be accounted for at the expiration of two or three months. Under condition that you receive at the end of one or two months, either the return of the original products or else a certain definite sum for those sold. Newspaper and magazine advertising is of very great value, as is advertising at beach resorts by street vendors.

Circularizing is another good method of advertising, but it is expensive, although not quite as expensive as consignment advertising.

(Continued on page 510)



The question of marketing the collar clip shown above is considered in the accompanying text.

Every Room an Outside Room

# Hotel Gregorian

42 West 35th Street

Near 5th Ave.

NEW YORK CITY

A High-Class Fireproof Hotel in the Very Heart of the City. Close to All Department Stores and Theatres. Within a few minutes to Pennsylvania and Grand Central Terminals.

ROOMS WITH BATH FROM \$3.00 PER DAY  
FOR 2 PERSONS \$5.00 PER DAY  
SUITES \$6 PER DAY

Very Attractive Rates by Day, Week, Month or Season.  
Ownership Management Assuring Personal Attention.

# INVENTORS PROTECT YOUR IDEAS

Send for our Guide Book, **HOW TO GET A PATENT**, and Evidence of Invention Blank, sent Free on request. Tells our terms, methods, etc. Send

model or sketch and description of your invention and we will give our opinion as to its patentable nature.

Name .....

Street .....

City .....

**RANDOLPH & CO.**  
Dept. 172, WASHINGTON, D. C.

# PATENTS

TRADE MARKS · COPYRIGHTS  
PROTECT YOUR IDEAS

ANY NEW article, machine, design or improvement thereof, or any new combination of parts or improvements in any known article which increases its efficiency or usefulness, may be patented, if it involves invention.

### IF YOU HAVE ANY NEW IDEAS

which you feel are useful, practical and novel, take prompt action to protect your rights. If you have invented any new machine, or new combination of parts of improvement, or any new design or process, SEND DRAWING, MODEL OR DESCRIPTION of it for information as to procedure to secure protection.

### WRITE TODAY FOR BLANK FORM "RECORD OF INVENTION"

USE THE COUPON attached, and immediately upon its receipt I shall send you this form to be returned to me with drawing, description or model of your idea; promptly upon receiving your idea I shall write you fully as to procedure and costs.

### NO CHARGE FOR THIS INFORMATION

All communications are held in strict confidence. My personal, careful and thorough attention is given to each case. I offer you efficient, reliable and prompt service—based upon practical experience. Highest references. WRITE TODAY for free books "How to Obtain a Patent" and "Invention and Industry." These books will give you valuable information, and may save you much time and effort. Send for them NOW. My practice is devoted exclusively to United States and Foreign Patents and Trade Marks. Write me freely, frankly and with full confidence; it is very probable that I can help you. Write TODAY.



Drafting and Specification Room of Clarence A. O'Brien, Registered Patent Lawyer, Washington, D. C.

## CLARENCE A. O'BRIEN

Registered Patent Lawyer

Member of Court of Appeals, District of Columbia, United States Court of Claims;  
Bar of Supreme Court of United States, Supreme Court, District of Columbia  
Practice Confined to Patents, Trade Marks and Copyrights

### FREE COUPON

CLARENCE A. O'BRIEN, Registered Patent Lawyer, Washington, D. C.  
536 Security Savings & Com'l Bk. Bldg., directly across street from U. S. Pat. Office.

Please send me your free booklets "How to Obtain a Patent" and "Invention and Industry" and blank form "Record of Invention" without any obligation on my part.

Name .....

Address .....

IMPORTANT—WRITE OR PRINT NAME PLAINLY

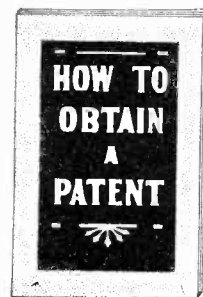
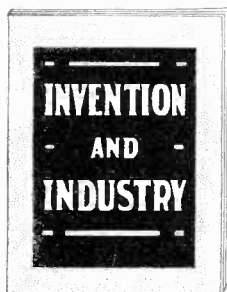

# MECHANICS' HANDBOOK



**330 PAGES**

**More than 300,000 sold**

**H**ANDIEST book of its kind ever written. Prepared by experts under the direction of the International Correspondence Schools. Written in language that you can understand. Note this partial list of subjects:

Only \$

Weights and Measures; Easily Understood Mathematics; Formulae; Mensuration; Belting; Hydro-mechanics; Strength of Materials; Boiler Design; Care and Inspection of Boilers; Horsepower of Boilers; Chimneys; Exhaust Heating; Machine Design; Horsepower of Engines; Boilers and Pumps; The Slide Valve; Belt Pulleys; Rope Belting; Cylinders and Steam Chests; Electricity; Currents; Wiring; Dynamos and Meters; Batteries; Cable Testing; Compass Surveying; Curves; Leveling; Etc.

Just mail this advertisement with a dollar bill and your name and address, and this 330-page I. C. S. Mechanics' Handbook or any of the other I. C. S. Handbooks that you want will come to you by return mail.

INTERNATIONAL CORRESPONDENCE SCHOOLS  
Box 6166-D, Scranton, Penna.

I enclose \$..... for which send me, postpaid, the Handbooks marked X, at \$1.00 each. It is understood that if I am not entirely satisfied I may return any or all of them within five days and get my money back.

MECHANICS' HANDBOOK  
 Automobile Handbook  Radio Handbook  
 Electrical Handbook  Salesman's Handbook  
 Chemistry Handbook  Advertising Handbook  
 Building Trades Handbook  Bookkeeper's Handbook

Name.....  
Address.....

**PATENTS** As one of the oldest patent firms in America we give inventors at lowest consistent charge, a service noted for results, evidenced by many well known Patents of extraordinary value. *Book, Patent-Sense, free.* Lacey & Lacey, 644 F St., Wash., D. C. Estab. 1869.

**LAW STUDY AT HOME**  
Become a lawyer. Legally trained men win high positions and big success in business and public life. Greater opportunities now than ever before. Be independent—be a leader. Lawyers earn \$3,000 to \$10,000 Annually. We guide you step by step. You can train at home during spare time. Let us send you records and letters from LaSalle students admitted to the bar in various states. Degree of LL. B. conferred. Thousands of successful students enrolled. Low cost. We furnish all text material including fourteen-volume Law Library. Get our valuable 120 page "Law Guide" and "Evidence" books FREE. Send for them—NOW. LaSalle Extension University, Dept. 9384-L Chicago

## VARIABLE CONDENSER

(824) Carlos Bohnenblust, Managua, Nic., C. A., submits a suggestion for variable condensers in which the plates are corrugated to produce greater surface area.

A. The variable condenser which you have designed is very poor indeed. Even though you do obtain a greater plate area in such a variable condenser, its construction is entirely too expensive.

A much better method of developing variable condenser plates is to make them in such a form that a thin layer of insulating material covers both surfaces of either the movable or rotating plates. In this way, there is no possibility of shorting the condenser, and the space between two plates is reduced to a minimum. Consequently the capacity of the condenser is greatly increased.

In your particular device the slightest bend in either group of plates would cause the condenser to be shorted. This condenser will clog with dirt much more easily and it would be relatively difficult to clean. It is also difficult to correct shorted plates.

We would not suggest that you apply for a patent on this device, as we do not see how you could possibly secure a sale for the same, even if a patent was granted.

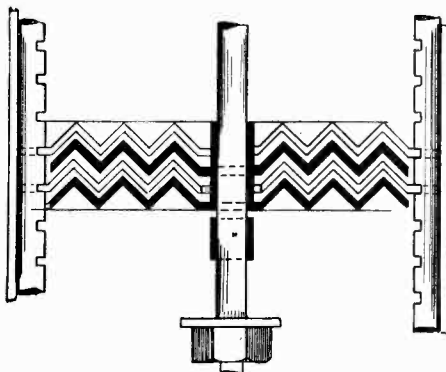

By corrugating the plates of the variable condenser the inventor believes that he will increase the surface area, and consequently the capacity of the condenser, without increasing its size. A patent is not advised.

## SIGN FLASHER

(825) E. A. Ramsay, New York City, submits a suggestion for a sign flasher, the nature of which is made clear in the illustration.

A. We certainly would not suggest your applying for a patent on your lighting apparatus. The idea is very poor and the possibility of controlling so many lamps from the pendulum of a clock is worse than poor. The flashing taking place at the contact points, and the effect in retarding the movements of the pendulum is too great to even make the device worthy of consideration. Systems, equally simple, controlled by small motors are far superior.

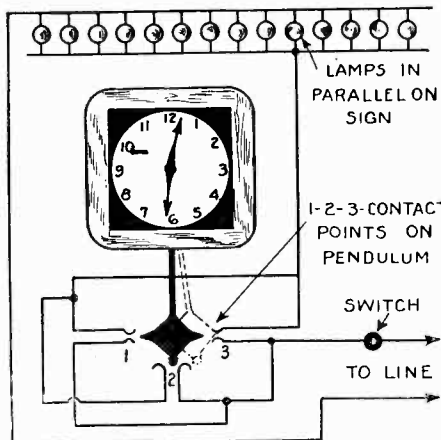

The sign flasher indicated is not thought worthwhile, and application for a patent is not suggested.

In sharp contrast to the fact that our American stations, as KDKA and WGY are going down to the very short waves, 50 to 100 meters, the powerful new British station at Chelmsford will use a wave-length of 2,500 meters.

The now internationally famous John L. Reinartz has just perfected a new transmitter working on five meters. Mr. Reinartz has given this wonderful invention to the Navy and has promised to give out information at a later date.



**\$10,000 a Year In Commercial Photography**

This picture was made for a catalog of Bathing Suits. Thousands of manufacturers now use photographs to sell their merchandise.

Magazines, newspapers, manufacturers, spend millions every year on commercial photographs. The man or woman who knows Modern Photography has an unlimited opportunity for success in this fascinating and big paying profession. During your spare time alone, you can make \$75 a week from commercial photographs or portraits. You can do modern professional work from the start and charge the same prices that other high grade photographers do. I guarantee to return every cent of your tuition if you are not absolutely satisfied.

## Learn at Home

No previous experience is necessary. You can make big money in your spare time while you are learning. Last Christmas, E. D. Blaut got more than the entire cost of the course for one family portrait group. You can do this, too! If you are ambitious, there is a tremendous opportunity for you in Modern Photography.



**FREE** I give every student a wonderful big, Professional Camera FREE. This wonderful offer is open for a limited time only. So write for information right away. Today!

International Studios, Inc.  
3601 Michigan Ave.  
Dept. 14-26 Chicago, U. S. A.

# PATENTS

## TO THE MAN WITH AN IDEA

I offer a comprehensive, experienced, efficient service for his prompt, legal protection and the development of his proposition.

Send sketch, or model and description, for advice as to cost, search through prior United States patents, etc. Preliminary advice gladly furnished without charge.

My experience and familiarity with various arts frequently enable me to accurately advise clients as to probable patentability before they go to any expense.

Booklet of valuable information and form for properly disclosing your idea, free on request. Write today.

**RICHARD B. OWEN, Patent Lawyer**  
164 Owen Building, Washington, D. C.  
2276-8 Woolworth Bldg., New York City

**C. L. PARKER**  
Ex-Member Examining Corps, U. S. Patent Office  
**Attorney-at-Law and Solicitor of Patents**

American and Foreign Patents secured. Searches made to determine patentability, validity and infringement.  
Pamphlet of Instructions sent upon request  
McGILL BUILDING WASHINGTON, D. C.

**Inventions Developed**

If you have an undeveloped invention, consult us. We will prepare practical designs for you, also procure your patent rights. Write for **FREE BOOKLET.**

**Manufacturers Patent Co., Inc.**  
70 Wall St., New York

# PATENTS

Trade-Marks, Copyrights and Patent Litigation  
Write for advice and instructions how to proceed, costs, etc.  
Hand Book with Illustrations of 100 Mechanical Movements sent free on request.

**ALBERT E. DIETERICH**  
Patent Lawyer and Solicitor  
Successor to Fred G. Dieterich & Co.  
602 OURAY BLDG. WASHINGTON, D. C.



## The Man On the Meteor

By RAY CUMMINGS  
(Continued from page 459)

They vanished in a swirl of water. I wheeled my dolphin toward Atar. His ten light-sleighs were in a line abreast, with him on his dolphin behind them. He gave a signal. The pods on the sleighs were unshrouded. Green light leaped ahead—a broad, blinding glare; and in the semi-darkness behind it, my electric men were gathered around me. Then I shouted my command, and we started vertically downward—our first attack upon the enemy.

### II

The glare of light showed the water plainly—a brilliant, ghastly green. We reached the sea-bottom, turned and dashed forward. The Maagogs were there. They saw our light coming of course, long before we saw them. A crowd of them, confused, half-blinded, but they were standing their ground nevertheless.

Over the line of light-sleighs I saw that we had to deal here with perhaps five hundred Maagog men. They seemed armed with spears. They huddled heavily against the sea-bottom, some half a mile from the edge of the forest. The line of them stretched back there, and more were constantly coming out.

When our sleighs were no more than a few hundred yards away, I shouted at Atar. At his relayed signal, the sleighs shrouded their pods and turned upward, out of reach of the enemy. It left the water in semi-darkness—blackness it must have seemed to the Maagogs, with that blinding glare so suddenly extinguished.

And then we leaped at them. It was a swirl of confusion, this hand-to-hand warfare. I held my dolphin resolutely above it, taking no part, but watching for every advantage into which I might hurl my men.

Looking down into the swirling water I could see the Maagogs fighting desperately to impale my swimmers with their spears. And my young Marinoids, darting over them, up and down, seeking to touch them head and legs simultaneously that the electric shock might kill them.

The fighting spread. Soon it was going on over a wide area. It was almost silent, uncanny fighting. The swish of the churning water—a shout, a death scream here and there. Bodies were dotting the sand. Maagogs, but Marinoids too. And the Maagogs in this first engagement outnumbered us two to one.

I was perhaps fifty feet above the sand, with the sleighs poised inactive immediately over me. Atar dashed up.

"How are they doing? Nemo, would it be better in the light?"

I had not thought of that. A trio of Maagogs, wounded and confused, came floundering up at us. Atar, from his dolphin, dispatched them easily with his sword.

"The lights!" he shouted. "Lights—and spread out—to light it all!"

The lights flashed on; the sleighs moved away to separate positions.

As though on a lighted stage, the scene was now illumined. It was a good move, for the Maagogs, living in the dark Water of Wild Things, could not stand the light as well as we could.

### THE CASUALTIES

Back to the edge of the forest the fighting was in progress. But my heart sank. There were two Maagogs dead to every Marinoid; but it was not enough. These were the weakest of Og's forces—and I was using against them the best of mine. Half an

# PATENTS TRADE-MARKS AND COPYRIGHTS

## OUR OFFER: No Charge for Examination and Instructions



### YOUR FIRST STEP

Before disclosing an invention the inventor should write for our blank form "Record of Invention." This should be signed and witnessed and returned to us together with model or sketch and description of the invention for examination and instructions. No charge for above information.

### Our Four Books Mailed Free to Inventors

Our Illustrated Guide BOOK

#### How to Obtain a Patent

Contains full instructions regarding U. S. Patents. Our Methods, Terms, and 100 Mechanical Movements illustrated and described, Articles on Assignment or SALE OF PATENTS, Patent Practice and Procedure, and Law Points for inventors.

#### Our Trade Mark Book

Shows the value and necessity of Trade-Mark Protection and gives information regarding Trade-Marks and unfair competition in trade.

#### Our Foreign Book

We have Direct Agencies in all Foreign Countries. We secure Foreign Patents in shortest time and lowest cost. Progress of Invention.

## VICTOR J. EVANS & Co.

VICTOR BUILDING - 779 - 9TH ST., N.W.

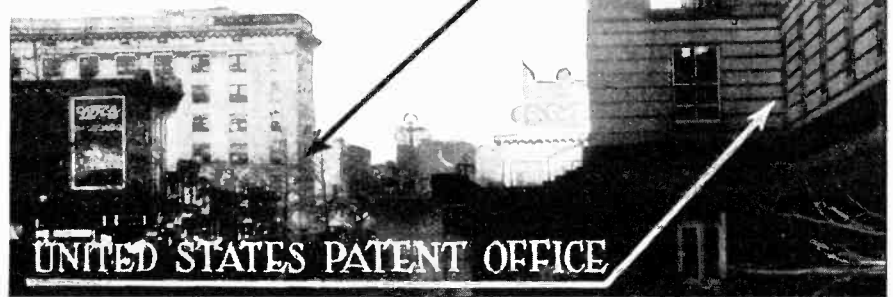

### WE REGARD A SATISFIED CLIENT

As our best advertisement, and will furnish to anyone upon request, lists of clients in any state for whom we have secured patents. All communications strictly confidential.

Highest References—Prompt Attention—Reasonable Terms

WRITE TODAY

FREE COUPON

VICTOR J. EVANS & CO., Patent Attorneys

New York Offices 1007 Woolworth Bldg. Philadelphia Offices 714-715 Liberty Bldg. Pittsburgh Offices 514 Empire Bldg. Chicago Offices, 1114 Tacoma Bldg. San Francisco Offices, Hobart Bldg.

Main Offices, 779 Ninth Street, Washington, D. C.

Gentlemen: Please send me FREE OF CHARGE your books as described above.

Name ..... Adress .....

# Reading Architects' BLUE PRINTS

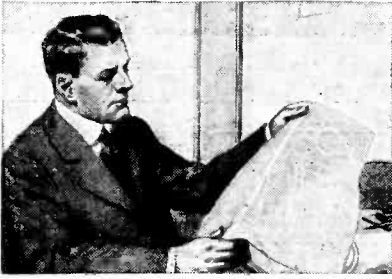

## Learn at Home!

THE building trades are booming. Employers everywhere are looking for men who can read architects' blue prints. Splendid salaries and rapid advancement are offered men who have this special training.

There is an easy, delightful way to learn. The International Correspondence Schools will teach you right at home in an hour a day of the spare time that now goes to waste.

You will like the course because it is so PRACTICAL. You work on actual blue prints—the same blue prints a contractor would use if asked for an estimate, or a foreman would receive from a contractor.

In a surprisingly short time you can acquire a knowledge of blue prints that will be of great value to you in a salary way the rest of your life.

Mail the Coupon To-day!

INTERNATIONAL CORRESPONDENCE SCHOOLS  
Box 6163-D, Scranton, Penna.

Without cost or obligation on my part, please tell me how I can qualify for the position or in the subject before which I have marked an X:

- | TECHNICAL AND INDUSTRIAL COURSES                                     |   |
|--|---|
| <input type="checkbox"/> Architect                                   | <input type="checkbox"/> Electrical Engineering                           |
| <input type="checkbox"/> Architects' Blue Prints                     | <input type="checkbox"/> Electric Lighting                                |
| <input type="checkbox"/> Contractor and Builder                      | <input type="checkbox"/> Mechanical Engineer                              |
| <input type="checkbox"/> Architectural Draftsman                     | <input type="checkbox"/> Mechanical Draftsman                             |
| <input type="checkbox"/> Concrete Builder                            | <input type="checkbox"/> Machine Shop Practice                            |
| <input type="checkbox"/> Structural Engineer                         | <input type="checkbox"/> Railroad Positions                               |
| <input type="checkbox"/> Chemistry <input type="checkbox"/> Pharmacy | <input type="checkbox"/> Gas Engine Operating                             |
| <input type="checkbox"/> Automobile Work                             | <input type="checkbox"/> Civil Engineer                                   |
| <input type="checkbox"/> Airplane Engines                            | <input type="checkbox"/> Surveying and Mapping                            |
| <input type="checkbox"/> Agriculture and Poultry                     | <input type="checkbox"/> Metallurgy <input type="checkbox"/> Mining       |
| <input type="checkbox"/> Mathematics                                 | <input type="checkbox"/> Steam Engineering <input type="checkbox"/> Radio |

- | BUSINESS TRAINING COURSES                       |  |
|---|--|
| <input type="checkbox"/> Salesmanship           | <input type="checkbox"/> Business Management                     |
| <input type="checkbox"/> Advertising            | <input type="checkbox"/> Industrial Management                   |
| <input type="checkbox"/> Better Letters         | <input type="checkbox"/> Personnel Organization                  |
| <input type="checkbox"/> Show Card Lettering    | <input type="checkbox"/> Traffic Management                      |
| <input type="checkbox"/> Stenography and Typing | <input type="checkbox"/> Business Law                            |
| <input type="checkbox"/> Business English       | <input type="checkbox"/> Banking and Banking Law                 |
| <input type="checkbox"/> Civil Service          | <input type="checkbox"/> Accountancy (including C.P.A.)          |
| <input type="checkbox"/> Railway Mail Clerk     | <input type="checkbox"/> Nicholson Cost Accounting               |
| <input type="checkbox"/> Common School Subjects | <input type="checkbox"/> Bookkeeping                             |
| <input type="checkbox"/> High School Subjects   | <input type="checkbox"/> Private Secretary                       |
| <input type="checkbox"/> Illustrating           | <input type="checkbox"/> Spanish <input type="checkbox"/> French |

Name \_\_\_\_\_  
Street \_\_\_\_\_ 3-6-24  
Address \_\_\_\_\_  
City \_\_\_\_\_ State \_\_\_\_\_

Occupation \_\_\_\_\_  
Persons residing in Canada should send this coupon to the International Correspondence Schools Canadian, Limited, Montreal, Canada.

**Electrical Engineering** Course for men of ambition and limited time. Over 4000 men trained. Condensed course in Theoretical and Practical Electrical Engineering including the closely related subjects of Mathematics and Mechanical Drawing taught by experts. Students construct motors, install wiring, test electrical machinery. Course complete

**In One Year**

Established in 1893. Prepare for your profession in the most interesting city in the world. Free catalog.  
BISS ELECTRICAL SCHOOL  
106 Takoma Ave., Washington, D. C.

### STOCK SELLING

Stock selling campaigns planned and executed by an expert; every detail handled quickly, economically, and effectively; established reputation.

WILLIAM R. THURSTON  
33 West 42d St. New York

hour more of such fighting and these first columns would be cut to pieces and routed. But what of that, if I lost nearly half of my finest men? There were the black fishes yet to cope with. My electric men would do best against them.

I saw now my mistake. I should have fought these lumbering Maagogs with my older, more numerous men. Spears against spears—and saved my youth for the black fishes.

Atar, I think, came to these conclusions simultaneously. Together we dashed over the scene of battle, calling off our fighters. They came readily, for the Maagogs, sorely harassed, were glad enough to let them go.

Up we started, but there were now no more than a hundred of us, where before there had been more than twice that. The light-sleighs, again shrouded, followed us. In the dimness down there, the sea-bottom was strewn with inert, broken figures—the wounded floundering—the water darkened with blood. And over toward the forest the Maagogs were retreating, to join fresh columns coming out. Then as we rose, the scene faded into obscurity.

"We must get back up," Atar called to me. "Get our older men—all of them—and come down again at once."

We were rising to where our waiting army would soon come into view, when off to the left I saw a cloud of tiny forms coming out of the upper recesses of the forest. Dashing at us, to cut off our ascent! Swiftly. I saw at once that our swimmers could not avoid them.

The black fishes! A swarm of them, with Og in their midst, was upon us!

### III

I must go back now to when—previous to our first attack—Nona with her girls left us to cross the forest. Nona led them; and swimming at tremendous speed they were soon above the vegetation. It was a queer sight, looking down through the water upon those marine tree-tops. A tangle of weeds; air-pods, some of them gigantic—the whole forest a matted thicket on top of which one could lie at rest.

But there were many places which would have served as entrance down—or exit up; which latter thought made my Nona shiver involuntarily. Down in the tangle—two thousand feet down—the Maagogs were passing through. What forces did they have? How many men? How many of the dreaded black fishes? Where were those black fishes—from which point would they attack us?

Nona knew that the fishes could best be fought by our electric men. The little beasts would be easy to shock and kill—but not easy, since they were so small, to impale upon a lance. Nona wondered where they were. If only she could get information of the strength and disposition of the enemy forces—information for me, so that I might intelligently plan my battle.

Woman acts upon impulse. Nona called her girl leaders—directed them to go on and carry out my orders—drive the Maagogs into the forest from its side toward Galna.

Then abruptly she halted her dolphin; the others swept on, leaving her alone in the silence of the water above the forest. At once she fastened her lance to the dolphin's back and dismounted; and the dolphin, understanding her reiterated, whispered command, held itself poised to await her return.

Nona planned to go down alone—swimming free-handed—into the forest to spy upon the enemy. She wasted no time; finding an open space between the tall spires, she dove into it.

The descent through those tangled, tenuous air-pods and plants, was laborious. She worked her way down, quietly, surreptitiously. It was almost dark, though not quite; and very silent. Far below now, she

# RADIO PAYS BIG

EARN \$3000 to \$9000 a Year

Enter fast growing radio field, thousands of big pay jobs waiting for you. U. S. Gov't., Steamships, R. R.'s, Corporations eagerly seek Radio trained men. Advancement rapid, earn from \$3000 to \$9000 yearly.



A. G. MOHAUPT

## Prepare for Big Pay in Spare Time

My reputation as Radio Engineer and instructor insures you complete, speedy success, at home in spare time; earn while you learn. I make you expert in radio designing, building, repairing and operating and teach you only practical "inside" dope. You quickly complete my course and step out into Big Pay. No experience required.

## FREE RADIO OUTFIT 1000 MILE TUBE SET

For a short time I will give tube radio set in handsome cabinet to men who enroll now, absolutely FREE. Send at once for my FREE wonder-book of inside Radio "dope."



A. G. MOHAUPT, Radio Engineer, RADIO ASSN OF AMERICA  
4513 Ravenswood Avenue, Dept. 69 CHICAGO  
Dear Sir: Send me your FREE Radio Book and your limited plan without cost or obligation.

Name \_\_\_\_\_  
Address \_\_\_\_\_ City \_\_\_\_\_

## CATALOG L-25-148 PAGES FREE!

Double "A" Super-Heterodyne  
ACME parts KIT only \$69.13

Panel engraved and drilled. Everything needed including Blueprints and instructions to build 7 tube set. Ready to hook up. DEALERS—SEND FOR Catalog and Discounts.

AMERICAN RADIO MFG. CO.  
WHOLESALE DISTRIBUTORS  
Dept. F, 6 WEST 14TH ST. KANSAS CITY, MO.

## Prices Reduced On All Standard Make-TYPEWRITERS



Lowest Prices in Years  
We will ship any make you choose for one week's trial. Underwood, Royal, L. C. Smith, Remington, Oliver, etc.  
Easy Terms Pay less than rent each month and own a typewriter. Guaranteed as good as new. Perfectly rebuilt by experts—the famous Young Process. Send for our free trial offer and new low price list now. WRITE TODAY.

Young Typewriter Co.  
World's Largest Dealers in Standard Typewriters  
654 W. Randolph St., Dept. 1169, Chicago, Ill.

2650 Miles ON ONE TUBE  
Broadcasting from Atlantic Coast, Mexico, Canada, Cuba and Hawaii, heard in California by users of CROSS - COUNTRY CIRCUIT  
Atlantic Coast users hear California. Range due to simplicity of set and operation by only one tuning control. Dandy and cheap to build by any one. Dry cell tubes may be used. Complete understandable instructions, full size panel layout, assembly photo, etc. Postpaid, 25c.; Stamps accepted.  
VESCO RADIO SHOP  
Box S. I. 117 OAKLAND, CALIF.



## Charge Your Battery For A Nickel

The Gold Seal Homecharger charges Radio and Auto Batteries at home overnight for a nickel. Your dealer has it. Write for FREE booklet and list of broadcasting stations.  
The Automatic Electrical Devices Co.  
116 W. 3d St., Cincinnati, Ohio

thought she could hear the sounds of voices. She was perhaps two-thirds the way down, when a sudden movement near at hand caused her heart to leap. Something human! She shrank behind a waving leaf, and clung. Peering into the gloom she saw a human figure—a Maagog. A woman—seemingly unarmed—a small female figure huddling in a branch of vegetation.

A Maagog! Nona could capture her—force from this enemy woman the information she sought.

My Nona plunged forward, with arms outstretched. Plunged silently, swiftly; and she was upon her enemy before the Maagog was fully aware of her. Their bodies met; the Maagog woman (she was no more than a girl) screamed; but Nona's hand went over her mouth.

They fought, tore at each other, with the Maagog girl's four arms gripping my Nona's frail body like the tentacles of an octopus. But Nona was the stronger; her body built of firmer flesh; her muscles more powerful.

**MAARET AGAIN**

Abruptly the Maagog girl yielded. They had been tumbling over and over in the water—wound and entangled with sea-weed; and save for that one scream, fighting silently. Nona pulled her captured antagonist to a tree-stalk, and in one of its branches, held her there firmly. And not until then did she realize that this was Maaret, the girl who loved Og—the girl who had helped us escape from the Water of Wild Things.

"You!"  
But Maaret now was crying. "What do you want of me? You go away. I hate you. You tried to take my Og. You let me alone."

Women are strange creatures! My Nona put her arms tenderly about the vehement girl.

"You must not hate me, Maaret. What are you doing here?"

"Og—he is down there. Fighting. For you, he fights—you, the woman who stole his heart. And he may be killed, and I love him."

What could Nona say? This girl had followed Og to the battle—followed, hoping to keep him out of danger because she loved him. And at the last, frightened, she had crawled away to the treetops—crying with fear and misery when Nona set upon her.

"Maaret, listen. You tell me where the black fishes are. Where is your Og?"

"There—in the forest." It was a vague answer—a gesture, not down, but off to one side, toward Rax.

"Still in the forest?"  
"Yes. I think so—I don't know. But he was going out to fight."

"The black fishes were with him?"  
"Yes."

"How many of them, Maaret?"  
But the girl had become suspicious. "I don't know," she said sullenly.

"He is on the sea-bottom with them? Maaret, listen. How many Maagogs are there in the forest?"

But the girl understood Nona's purpose and set her lips tight.

"No!" burst out the girl. "You would do my Og harm. I want to help him, not you."

She tried to pull away, but Nona held her. Nona's anger was rising.

"I'll take you with me," she told the girl. "My Nemo will make you talk."

But Maaret resisted, and suddenly her tears came afresh.

"You let me go. I should be with Og—fighting beside him because I love him. I was a coward to come up here."

The words appealed as none others could to Nona. Her anger vanished; sympathy flooded over her.

"You want to fight for Og, Maaret?"  
"Yes! I want to fight—I belong there—beside him. Let me go."

**USE "RAGECO" TOOLS TO BUILD BETTER RADIO SETS**

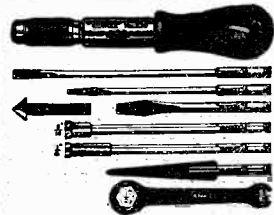

**CS-701 RADIO TOOL SET**

This is the handiest set of tools ever made for Radio Work by the makers of the famous "YANKEE" Tools. It contains the following: 1 Ratchet Screw-driver, 6 1/2 in. long, holding all attachments: 1 Blade, 5/16 x 3/16; 1 Blade, 3/8 x 1/8; 1 Blade 2 1/2 x 1/4; 1 Countersink; 2 Socket Wrenches for all small nuts; 1 Reamer to enlarge holes in panel from 1/8 x 3/8; 1 Wrench, one end 5/16" square or hex, for jack, other 1/2" hex., etc.

Price per set .....\$3.00



**CS-303 HAND DRILL**

The hardwood handle is hollow to store drills. Iron frame, nickel-plated parts, ball bearing three jawed chuck holding and centering accurately round shank drills from 0 to 3/16. Length of drill, 12 inches.

Price .....\$2.25

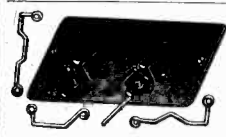

**CS-203 WIRE BENDING TOOL**

For making eyes, loops, bends, and offsets on Bus Bar wire. With this device any Radio Constructor can wire his set to compare favorably with any factory made set. Easier to use and more accurate than pliers. Full directions in box. Made of heavy steel, bled and finished.

Price .....\$1.00

**CS-402 CIRCLE CUTTER**



Especially designed for the Radio Constructor. Made of the finest material and equipped with the highest grade high steel cutting bits. It does three things at once. It drills its own pilot, cuts out plug and puts bend or scroll around the hole in one operation. Cuts holes 1/2 to 1 in. in diameter.

Price .....\$3.00

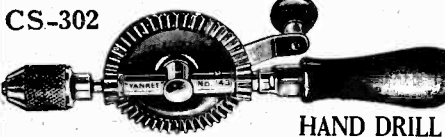

**HAND DRILL**

Especially designed for Radio Work by the makers of the famous "YANKEE" Tools. A beautiful balanced, small, powerful drill, with 4 to 1 ratio of gears for speed. Special chuck 9/32" capacity, to take largest drill, mostly furnished with drill or tool sets. Length over all, 9 1/2 in. Weight 1 1/2 lbs.

Price .....\$2.75



**201-A TYPE TUBES PRICE \$3.45 Each**

1/4-Amp., 5-6 Volts

201-A Type Tubes in stock for immediate delivery. Tubes that give the best results over the longest period of time and at your call at all times. Quiet in operation and highly sensitive. Note our special low price.

Order by order numbers. Remit by check, money order, stamps or cash. All goods are shipped free of transportation charges to all parts of U. S. and possessions same day as order is received. If not satisfied, money will be refunded upon return of goods.

**The Radiogem Corp.**  
66-S-West B'way, N. Y. City

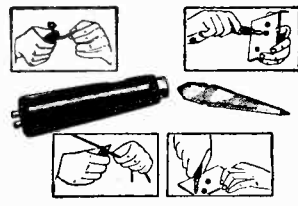

**CS-702 RADIO HAND-TOOL**

Bends Bus Bar or wire strips and scrapes wire, bores and reams holes, etc. Tool consists of 4" black japanned handle, to which is attached wire bending device, with nickeled ferrule and 3" long two sided reamer.

Price .....\$0.50



**CS-703 TOOL CHEST**

Set consists of "LOCK-Grip" master handle, 5" long, black Rubberoid finish with steel chuck, nickel plated, buffed and with the following 9 tools: Saw, bradawl, large screwdriver, file, scratch awl, gimlet, reamer, chisel, small screwdriver. Each tool of fine steel, drop forged, tempered, hardened, and nicely finished. Set comes in leatheroid box with tray.

Price .....\$1.85

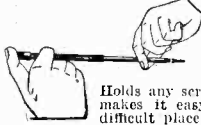

**CS-304 SCREW STARTER and DRIVER**

Holds any screw by its slot with a firm grip, makes it easy to place and start screws in difficult places. Just the tool for the Radio Constructor. All parts heavily nickeled and polished.

Price .....\$1.00

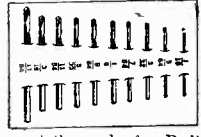

**CS-305 RADIO DRILL SET**

Composed of 10 straight shank twist drills, fitting all hand and breast drills. The selection of these drills has been especially made for Radio Constructors and consists of the following sizes: 1-16, 5-64, 3-32, 7-64, 1/8, 9-64, 5-32, 11-64, 3-16, 17-64. Drills are mounted on white Holland Linen with sizes clearly marked.

Price .....\$1.25



**CS-800**

**ELECTRIC SOLDERING IRON**

A perfect tool for Radio Work. Operates either on 110-volt A.C. or D.C. The heat element is of Nichrome, which prevents overheating and assures the desired even temperature. Size of Iron, 10 1/2 in. long. A 4-foot cord and plug is furnished.

Price .....\$2.00



**THE RADIOGEM**

Complete Radio Receiving Outfit

\$2.50

This outfit is absolutely complete. Nothing more to buy—no batteries or tubes needed—no upkeep of any kind. The simplest radio outfit made—you build it yourself. So simple that anyone can construct it. Complete instruction book with every outfit.

Complete Radiogem Outfit .....\$2.50  
The Radiogem only ..... 1.00  
The Gemphone only ..... 1.00  
Aerial Outfit only ..... .50

WE CARRY A COMPLETE LIST OF RADIO TOOLS. NO MATTER WHAT YOU WANT WE HAVE IT IN STOCK. WRITE FOR OUR COMPLETE TOOL LIST.

**8 HOUR BATTERY CHARGING EQUIPMENT PAYS BIG PROFITS**

8-Hour Battery Charging easily adds big monthly profits to your income. No experience needed. Outfit comes complete with charger, bus bars, bench, connectors, cables, etc. \$35 cash puts HB 8-Hour Battery Charger in your shop. Your profits easily carry small monthly payments. More HB's in use than any other make. HB users make big money giving better battery service to motorists. Write today for free bulletin 90.

HOBART BROS. CO., BOX S-9, TROY, OHIO.

**\$35 PUTS COMPLETE BATTERY CHARGING EQUIPMENT IN YOUR SHOP**

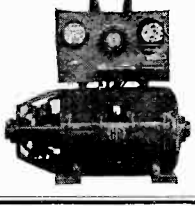

Insure your copy reaching you each month. Subscribe to Science and Invention—\$2.50 a year. Experimenter Publishing Co., 53 Park Place, N. Y. C.



**Enter the Profession of  
ELECTRICITY**

**Through This New Kind of  
Home Training System**

The great field of Electricity has never before needed so badly, Trained Men—men who are skilled in every department of this fascinating profession. The electrical industry is ready and glad to pay big salaries to the men who really know! Commercial Electrical Engineers, Master Electricians, Electrical Engineers, Automotive Electrical Experts, are needed everywhere, and they command handsome incomes. We will fit you for one of these splendid places quickly and thoroughly, right in your home, while you hold your present job.

**Unlike All Other Schools**

No other school furnishes its students with the elaborate Home Laboratory Units—actual working size Instruments, chemicals and electrical equipment. This gives you actual practice, along with the theory, making you a skilled expert ready to take a big job. In addition, our official Broadcasting Station WIAO broadcasts educational lectures on Electricity, richly supplementing the studies and experiments of our home-study students.

**FREE HOME LABORATORY  
OUTFIT COMPLETE**

No models, or miniature parts, but actual size apparatus and equipment, the same as you work upon when out in the field. Do not confuse these Laboratory Units with the models sometimes furnished by correspondence schools. They are sent to your home without cost to you, as a part of your course. It is only through the enthusiasm and cooperation of our myriad of students that we can go to this enormous expense. You will get complete details of this amazing plan when you write.

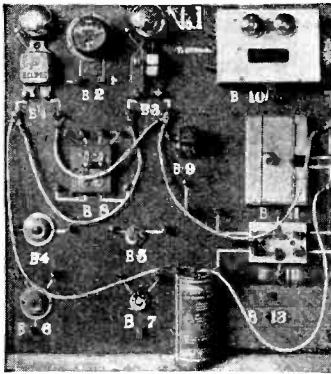

**Satisfaction Guaranteed  
Backed by This Great School**

This marvelous training is backed by the largest and best equipped electrical school in America. The School of Engineering is endorsed and linked with some of the largest Commercial Concerns and Power Companies in the country, the employers of the Big Pay Men.

**Catalog Sent FREE**

Write quick, just mailing the coupon, for complete details and catalog. It will point the sure way to success.

Extension Division

**SCHOOL of ENGINEERING  
of Milwaukee**

Dept. SI-H924

415 Marshall Street Milwaukee, Wisc.

SCHOOL OF ENGINEERING OF MILWAUKEE,  
Dept. SI-H924, 415 Marshall St., Milwaukee, Wisc.

Please send me your Free Catalog and details of your new home training system in Electricity.

Name..... Age.....

Address.....

City..... State.....

Nona stared into the girl's pathetic little face.

"Go," she said. "You speak truth, Maaret. You belong there with the man you love, no matter for what cause he fights. Go!"

Her gaze followed as Maaret dropped away, down into the recesses of the forest.

IV

It was a terrible moment as we saw those black fishes, with Og in their midst, dashing at us. Atar and I shouted to our men—shouted encouragement. We could not avoid this new enemy; and so we had to plunge at it with a will. A hundred electric men, no more, and all of them were exhausted by the combat they had left but a moment before.

Our light-sleighs were of little use here; hastily we sent them speeding upward, to bring down our main army to our assistance. Atar and I on our dolphins circled about. The black fishes were everywhere; confusion again; the lashing figures of our young men as they met the black, ugly little things—all jaws, and teeth like needles.

A hundred personal battles simultaneously. But there were ten fishes to each of our men at least. The fishes were shocked and killed—some of them. Others bit and tore at our fighters' flesh.

Have you ever seen a school of hungry fish pluck at a bit of food? Dismember it—carry it away? This was like it. . . .

Shuddering, I dashed my dolphin to and fro. A few of the fishes I caught on my lance. But so very few among that thousand.

This was disaster. We would kill half the fishes perhaps—but lose all this portion of our men. Disaster.

I became aware of Atar's dolphin rushing past me; his voice shouting:

"Og! Let us get Og! Force him to call off the fishes! Or kill him!"

Og had been holding himself poised in mid-water, watching the scene. But already he had realized his danger. He was making away; and at his call a hundred or more of his fishes gathered around him.

We would have dashed at them; our two dolphins could have scattered them.

But we did not; for from below, a swarm of other figures appeared. Marinogs! The half-breeds! A picked corps of Marinog youths. They were good swimmers. They possessed the power of electric shock. More than a hundred of them were rising now to Og's assistance.

Atar and I stopped our onslaught. Around us on every hand our scattered forces were fighting the fishes. But the little groups of men fighting were now very few; everywhere bodies were sinking inert, with swarms of fishes plucking at them. . . .

We screamed for all to follow us who could; and mounted. A few of our men tried to follow—but not one succeeded. The oncoming Marinogs, fresh and lustful, caught them all.

And with hearts cold within us, Atar and I dashed on upward, alone.

V

Nona regained her mount above the forest, and continued on to join her girls. I can tell you this part of the battle only as Nona told it to me—briefly, for my Nona talks little of her own deeds.

The girls on the dolphins were beyond the forest, down near the sea-bottom. And they were engaged with the enemy when Nona arrived.

It was the last of the Maagog columns, just entering the forest when the dolphins attacked it. A very brief engagement. A few score of the last, heavy-swimming Maagogs. And without trouble the girls cut them down—drove them into the forest.

Atar and I, rising alone from our defeat, met our main army coming down to help

**100**

**PRACTICAL  
AUTHENTIC  
RADIO  
HOOKUPS  
FOR—  
25c Prepaid**

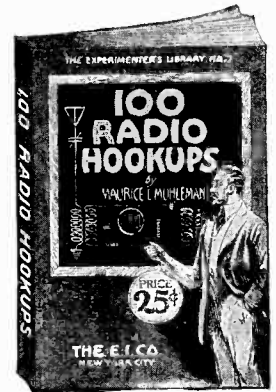

No Radio Hookup book on the market can equal this handy 52 page book in price or the quantity of information contained in it. All data is compiled by a radio expert with years of experience and is edited so that every word can be understood and the diagrams and drawings can easily be followed. Thousands of the books have already been sold. We have had to make a second edition which is now ready for distribution. Get your order in early so that you will have this book for the fall season.

**ALL ORDERS  
FILLED WITHIN  
24 HOURS**

*You Can Obtain a Copy  
At All Reliable Radio  
Dealers.*

**E.I. Company**

**CONSRAD CO.—Selling Agents  
233 Fulton St., New York City**

us. The light-sleighs had carried the news. Hastily we told them of our disaster. It was my fault, no doubt; I should never have split my forces. How easy it is to look back and say what should have been done!

Atar was anxious to descend at once, with all our men, in one desperate attack. But I was learning the art of warfare. Inexperienced still, yet now not wholly so. We must wait here, I told them, for Nona and the girls to return. Then we would be completely united. And by then the enemy would be on this side of the forest. In the open, we would attack them with all our forces at once, as Atar said.

"Look!" shouted Atar.

Above us, in the direction of the forest, the blur of swiftly moving forms showed, with lines of white, V-shaped, behind them.

VI

It was Nona and her girls—victorious in what they had undertaken. The news heartened us. We had lost a few of the girls and dolphins—and two hundred and fifty of our best men. But we had done the enemy all told a more than equal amount of damage.

For half an hour we waited. Atar and I twice cautiously descended. The Maagogs seemed all out of the forest—and were advancing on Rax. High over them in the water, we followed; and almost within sight of Rax, we dove down in a mass upon them.

It was a scene of carnage which at first seemed inextricable confusion. My forces spread out—attacked the enemy everywhere at once. The Maagogs seemed to prefer the sea-bottom; they clung there and fought stubbornly.

At Atar's insistence, I held my dolphin at first in mid-water, out of range of the fighting. Below me was the center of the struggling mass—the main force of sword-armed Maagogs. Against them, in the glare of Atar's light-sleighs, I hurled my older men. They were fighting down there in the brilliant light. We were outnumbered in this section, but I could see that my men were more than holding their own.

Off to the left—toward the forest—a cloud of the black fishes had come up. With them were the Marinog electric men; and against them I sent my own two hundred and fifty youths—and the girls and dolphins.

It was this segment that I most feared. I could see them now; the men were locked in hand-to-hand conflict—lashing the water—hundreds of little groups. The black fishes were mingled with them; and about the whole struggling mass, the girls on the dolphins dashed back and forth.

How long I watched I do not know. I was alone, save that near at hand were Caan and his dark-sleighs, holding themselves in readiness.

A Marinoid fighter came wavering up to me, wounded and gasping.

I descended. The fighters in this central melee had split into two separate sections—and on one side were far outnumbered. Atar was down here; he saw me, and rushed forward.

THE INK POTS

"Nemo—on this side we lose."

It was impossible to transfer quickly any considerable number of my men from one side to the other.

"Take the lights from the losing side," I shouted; and when Atar had dashed away, I swam my mount up to Caan.

With his dark-sleighs, we swept down into the threatened area. Men were fighting all around us; the dead were everywhere. The ink-bags on the sleighs released their fluid; the water darkened—turning to night.

Back and forth I scurried through the darkness, screaming to my men to shake off their foes—to extricate themselves and rise

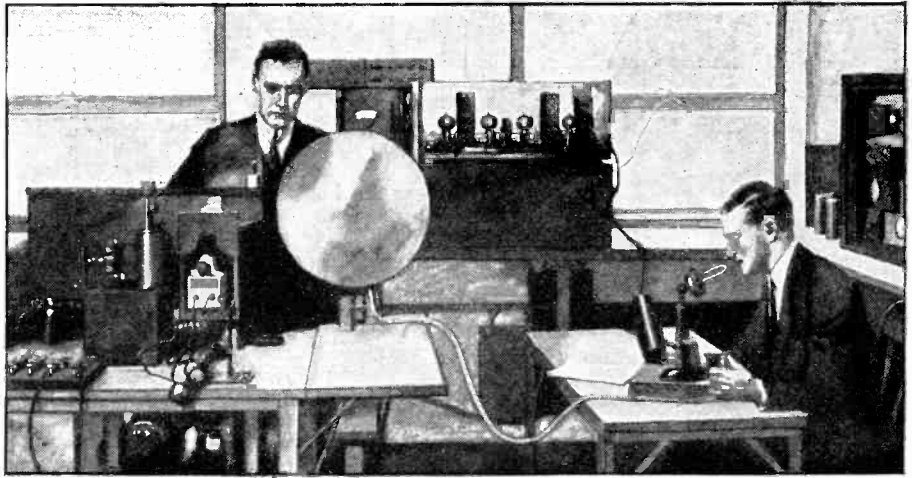

In the Bell System laboratories speech sounds are recorded on the oscillograph with a view to their subsequent analysis

# The service of knowledge

The youthful Alexander Graham Bell, in 1875, was explaining one of his experiments to the American scientist, Joseph Henry. He expressed the belief that he did not have the necessary electrical knowledge to develop it.

"Get it," was the laconic advice.

During this search for knowledge came the discovery that was to be of such incalculable value to mankind.

The search for knowledge in whatever field it might lie has made possible America's supremacy in the art of the telephone.

Many times, in making a national telephone service a reality, this centralized search for knowledge has overcome engineering difficulties and removed scientific limitations that threatened to hamper the development of speech transmission. It is still making available for all the Bell companies inventions and improvements in every type of telephone mechanism.

This service of the parent company to its associates, as well as the advice and assistance given in operating, financial and legal matters, enables each company in the Bell System to render a telephone service infinitely cheaper and better than it could as an unrelated local unit.

This service of the parent company has saved hundreds of millions of dollars in first cost of Bell System telephone plant and tens of millions in annual operating expense—of which the public is enjoying the benefits.



AMERICAN TELEPHONE AND TELEGRAPH COMPANY AND ASSOCIATED COMPANIES

## BELL SYSTEM

One Policy, One System, Universal Service

**FREE with BIG 3 FT. TELESCOPE**

See people and objects miles away, on land or sea, as if they were close. Wonder Telescope gives new pleasures to home, farm, camp, travel, sport. See moon and stars as never before. Opens out over 3 feet long, in 5 sections; measures 12 inches closed. Brass bound; has powerful lenses. Thousands pleased—"Could tell color of aeroplane 4 miles away."—Mrs. Yarbrough. "Saw Provincetown Light, 28 miles away, as clear as if in front of me."—Clyde Scriber. "I have been watching submarine 8 miles off the coast."—P. Grubb. "Can see children playing in school yard 8 miles away."—P. H. Hennington. "Read the numbers on freight cars mile away, see mountains on moon"—A. C. Palmer. Because of fortunate purchase from large European maker we can give you a big bargain. Be first in your neighborhood, entertain your friends. Send no money; send only name and address for telescope and case by parcel post. On arrival deposit with Postman only \$1.85 plus a few pennies postage. Satisfaction guaranteed or money refunded. Order today while supply lasts.

**Send No Money**

Clip This Ad

**FERRY & CO., 630 W. Jackson Blvd., Dept. 1256 Chicago, Ill.**

**Wrestling Book FREE**

Be an expert wrestler. Learn at home by mail. Wonderful lessons prepared by world's champions Farmer Burns and Frank Gotch. Free Book tells you how. Secret holds, blocks and tricks revealed. Don't delay. Be strong, healthy. Handle big men with ease. Free Book. State age. Farmer Burns School, 1256 Railway Bldg. Omaha, Neb.

**"BECOME A LIGHTNING TRICK CARTOONIST"**

Make money chalk talking. Send \$1 for snappy program of trick drawings, with instructions by a professional cartoonist. Satisfaction guaranteed. Circular free. Balda Art Service, Dept. 4, Oshkosh, Wis.



You may have the talent to develop into a Saxophone wizard like Tom Brown, of the famous Tom Brown's Clown Band, and enjoy this most pleasant of vocations. Buescher Band and Orchestra Instruments have helped make famous such leaders as Paul Whiteman, Jascha Gurewich, Clyde C. Doerr, Bennie Krueger, Ben Selvin, Joseph C. Smith, Dan Russo, Gene Rodemich, Henry Santrey, Zez Confrey and thousands of others. \$100 to \$500 weekly for a few hours a day is not uncommon for musicians of ability to earn.



**Easy to Play  
Easy to Pay** True-Tone  
**Saxophone**

The Buescher Saxophone is so perfected and simplified that it is the easiest of all musical instruments to learn. It is the one instrument that everyone can play—man or woman, boy or girl—and it wholly satisfies that craving everybody has to personally produce music. You can learn the scale in an hour's practice, play popular music in a few weeks and take your place in an Orchestra or Band within 90 days, if you so desire. Nothing can take the place of a Saxophone for home entertainment, church, lodge or school. It increases the pleasure you get out of life, increases your popularity and your opportunities.

**FREE Saxophone Book**

Six days' free trial and easy terms of payment arranged on any Buescher Saxophone, Cornet, Trumpet or other instrument. Just fill out and mail coupon for Free Saxophone Book or Complete Catalog.

**Buescher Band Instrument Co.**

Everything in Band and Orchestra Instruments

153 Buescher Block Elkhart, Ind.

Gentlemen:  
I am interested in the instrument checked below:

Saxophone..... Cornet..... Trombone..... Trumpet.....  
(Mention any other instrument interested in)

Name .....

St. Address.....

Town..... State.....

into the light. In the blackness my dolphin struck many struggling forms—friend and foe alike.

Then I went up, out of the cloud of ink, again into the blessed light. And waited, while in little groups, my sorely pressed fighters struggled up after me.

It was instinct for everyone to escape from that horrible darkness. Have you ever fought in the dark? It strikes a terror to the soul.

The Maagogs must have felt it, as well as my own men. In the black, inky water, all fighting soon ceased.

And here I saw my opportunity and grasped it. The Maagogs, confused and terror-stricken, were floundering out into the light. They came singly. And their eyes—weaker than those of the Marinoids—could see little when first they emerged.

For many minutes the inky water held together. And around its edges, Atar with his light-sleighs swept their dazzling beams back and forth. There were six or seven hundred Maagogs in there—and as they came out a few at a time, we fell upon them.

It was our great opportunity. And then I realized that I could do the same thing with the other wing. If only I had my other forces here! The girls with the dolphins!

Atar and Caan executed the same maneuver, while I dashed away to get Nona. In this third sector things had gone very well indeed. The girls had suffered few casualties. They were fighting the Marinogs—holding them in check, while my electric men dispatched the black fishes.

I searched about for Nona, came upon her in time to see what manner of warfare this was. Three Marinogs had made for her. She went at them full tilt, with lance extended. They scattered; but incredibly swiftly she turned her dolphin, impaled one of them with her lance—then another, while the third for his life, turned and made away. "Nona!" I called. "Bring your girls! Come—we need you!"

With the girls behind me, I hastened back to Atar and Caan. Out of the inky water below—into the brilliant beams of our light-sleighs—the surprised Maagogs were emerging. The girls rushed at them—the dolphins, extraordinarily swift, seemed to be everywhere at once.

The ink finally cleared away; and my own remaining fighters took a hand. The combat turned to slaughter—then a complete rout.

And I had men free now to send to the other sector, weakened by the withdrawal of the girls. The black fishes and the Marinogs there were overpowered. The fishes fought to the last. A few of the Marinogs fled—back to the Water of Wild Things. And from everywhere about the scene of battle, wounded Maagogs were floundering away.

But we let them go.  
We had won.

VI

*Concluding Statement by Ray Cummings*

I feel that I should add a few words to this last manuscript given me by "Nemo." You will recall that I have already told you he is an inmate of one of our State Homes.

Each month this queer old man has been writing for me these memories of his youth. But the Institution officials, with pardonable skepticism, declare to me privately that he is unbalanced—a victim of amnesia since that day he was found wandering on the streets of an American city, with no memory of who he was or where he came from. They tell me he was, in his youth, probably some obscure European astronomer—which would account for his scientific knowledge. Scandinavian perhaps, they now say. His accent is curious, I can hear for myself. But I

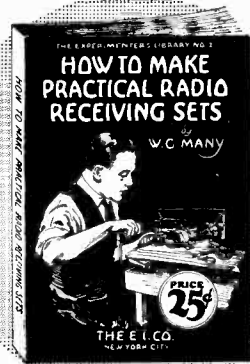

**BUILD  
"Practical" Sets  
For Practical Results**

For the man who wants to select a Radio Receiving Set that is practical, efficient, tried and tested by time, the E. I. Co. Book No. 2 will be invaluable to him. This book contains a selection of the best practical Radio Hookups on the market today from the small but efficient crystal Receiving set to the standard Radio and Audio frequency hookups so popular today. The book gives complete instructions on how to build each set, with a wiring diagram of each circuit. It is profusely illustrated and is written in plain language so that the instructions can be followed quickly and easily.



**PREPAID**

Book No. 2 HOW TO MAKE PRACTICAL RADIO RECEIVING SETS, size 3 1/2 x 7 3/4 inches, 48 pages. Profusely illustrated, bound in stiff cardboard two-color printed cover. Price postpaid 25c.  
You can obtain one of these books at your local Radio Dealer or by writing direct and enclosing 25c to

**E.I. Company**

CONSRAD CO., Selling Agents

233 Fulton St., New York City

**MODEL MAKERS—SCIENTIFIC EXPERIMENTERS—INVENTORS—STUDENTS**

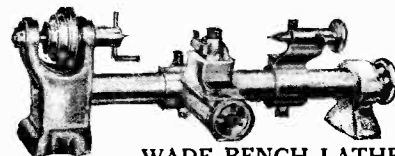

**WADE BENCH LATHE**

For METAL—WOOD—EBONITE—TURNING—BORING—DRILLING—FACING—THREAD—CUTTING—WINDING. CAPACITY—4" dia. x 12" length. Lead screw protected inside bed. Slide-rest has a travel of entire length of bed and is fitted with cross feed.

**STRONG—ACCURATE—QUIET—SIMPLE**

A Real Machine Tool for the Home Work Bench at a Reasonable Price. Requires less space than a sewing machine and operates even more quietly.  
Send for Latest Literature—Price \$25.00 F.O.B., N. Y.  
THE GEROLD COMPANY, 120 Liberty St., N. Y. City

*Learn to Write*

Begin Today—Write for My FREE BOOK. I can make a good penman of you at home during spare time. Write for my FREE BOOK, "How To Become a Good Penman." It contains specimens and tells how others mastered penmanship by the Tamblin System. Your name will be elegantly written on a card if you enclose stamp to pay postage. Write today for book.

**P. W. TAMBLIN, 424 Ridge Bldg., Kansas City, U.S.A.**

would not call it Scandinavian; indeed I have heard nothing like it anywhere.

It was not so many weeks ago—dating from the time you read this—when I interviewed the old man, in the neat little reception room of the Institution. I read over this last manuscript which he handed me, while he sat staring with eyes that seemed to see far beyond the narrow walls enclosing us.

"But Nemo," I protested, "this is not finished. Is this the last you're going to give me?"

"The last," he said vaguely. "I cannot remember any more. It is getting blurred—fading." He passed a palsied hand across his blue-veined forehead. "Getting blurred—for I am an old man and my faculties are going—very fast."

"But Og," I suggested. "What became of Og?"

He brightened. "Did I not tell you that? I remember now. I met him—near the end of the battle. He had captured one of our dolphins, and a lance. He came at me—and I fought him—I was mounted as he was.

The tired old voice trailed away.

"Yes?" I prompted.

He started. "What was I saying? Oh yes, about Og. You asked me about Og, didn't you? We might have been knights of the Court of King Arthur—jousting with our lances. I can remember it now—clearly. I would have run him through almost at the first tilt, but that girl threw herself between us. I did not like to kill her. That was bad. Accidental—I could not help it."

"You mean Maaret?"

"Maaret? Yes, that was her name, wasn't it? I remember now. She died in Nona's arms—after I had killed Og. The girl did not know I had killed him. She died—still loving Og, and glad that she had given her life for him. . . . I remember that now."

It was all fading in his mind; I realized that, and made a last effort.

"But Nona and your boy? What of them? And you, Nemo—who are you?"

He seemed struggling with the shadows that were enveloping him.

"I—I don't know. I remember that at the last, I was with Nona and boy. The war was over. I was sick. Yes, that was it—very, very sick. They had me in bed. Nona was bending over me. I can see her now—so beautiful. It was getting dark, but Nona said—"

He stopped short.

"Nona said—" I prompted gently.

"Yes, I recall it now. Nona said I must fight the darkness that was creeping upon me. But I couldn't. It came—darkness and silence. Slowly. But everything was growing black. And Nona's voice imploring me not to go, grew dimmer—far away—dimmer and darker—everything dark, and then—I was gone."

"Dead?" I said softly. What did he mean? What could it all mean, except what the rational officials of the Institution said?

He shook himself slightly. "Did I say dead? I don't know whether I mean that or not. I don't know what I mean. Blackness—nothingness—and then I found myself on one of your horrible crowded streets here on Earth. An old man—cheated out of all those years of life—grown old and feeble, when last I had been young and strong. And my Nona and boy gone—"

He was trembling now; and suddenly he turned on me.

"Go away, please. It—it hurts me to think these thoughts. My Nona gone—"

If any of you care to advance your theories, I shall be glad to hear from you.

And I thank you, on Nemo's behalf, for your interest these past nine months.

RAY CUMMINGS.

THE END.

Aladdin would have liked to meet this young lady. He had a good lamp; but see this!



## The biggest and the smallest

The biggest lamp made by the General Electric Company is 30,000 watts, equivalent to 100,000 candles. The smallest is called the "grain of wheat" lamp. It is used in surgical operations on the stomach.



While the cost of almost everything else has advanced since the war, the cost of MAZDA Lamps—and the current for lighting them—has been materially reduced. Use the right lamps and use them freely; no other home comfort costs so little.

Both are MAZDA Lamps, like the lamps in your home—MAZDA being the mark of the continuous research service centered in the General Electric laboratories in Schenectady.

# GENERAL ELECTRIC

**"THERE'S MONEY IN IT"**

**AT HOME LEARN TELEGRAPHY AT HOME**

**MORSE AND WIRELESS**

**TEACH YOURSELF** in half usual time, at trifling cost, with the wonderful Automatic Transmitter THE OMNIGRAPH. Sends unlimited Morse or Continental messages, at any speed, just as an expert operator would. Adopted by U. S. Government and leading Universities, Colleges and Telegraph Schools. 3 styles. Catalog free.

If you own a Radio Phone Set and don't know the Code, you are missing most of the fun.

**OMNIGRAPH MFG., CO. 22 Hudson St., NEW YORK**

**"LIGHTING FIXTURES"**

**READY TO HANG**

Direct from manufacturer. Completely wired including glassware. Send for Catalogue No. 26 (Just off the Press)

*Special Proposition to Dealers*

**ERIE FIXTURE SUPPLY CO.**  
Desk B Erie, Pa.

**SEND FOR THE INTERNATIONAL CATALOG**

Our net price list. Full line of auto bodies and accessories for Fords at Wholesale Prices. Save big money on bodies by buying Direct from Factory.

**FOR FORD—Prices from \$27.85 up.** Factory to consumer direct—Pay only One Profit

**International Body Works, 914 W. Ohio St., Dept. 4, Chicago, Ill.**

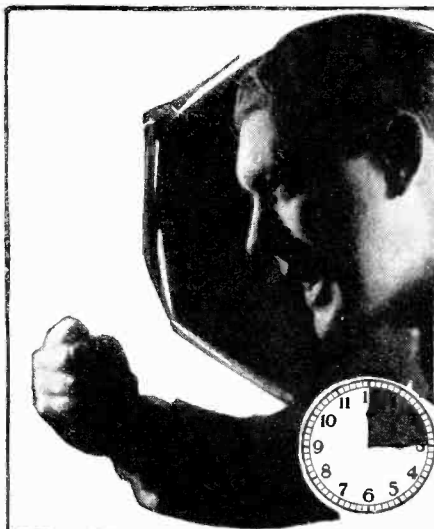

# I Guarantee To Make You A Public Speaker Or I Won't take a Penny

*I will show you how to control one man or an audience of a thousand. How to conquer "Stage fright." How to increase your earnings quickly through this amazing new method.*

## 15 Minutes a Day

That's all I want, 15 minutes a day to prove absolutely and beyond a shadow of a doubt that I can do for you what I have done for thousands of other men—**increase your income, make you successful, make you a leader.**

C. F. Bourgeois, President of Robischon and Peckham Company says: "The lesson on 'How To Develop Personality' is alone worth the entire cost of the course. It has been of real practical help to me."

Walter O. Ford of the Ford Manufacturing Company writes: "Was always considerably flustered when called upon to speak. Now, thanks to your course, I feel perfectly at home and confident. Every man who wants a strong personality and the power of effective speech should take your course."

These are big men in their fields and they know that the man who can hold others beneath the spell of powerful speech has the world at his feet. Others of equal ability in every other respect are passed by unnoticed because they lack the power to impress others. And yet, there is an amazingly easy way to acquire quickly the power of vital convincing speech.

I don't care what line of business you are in. I don't care how embarrassed you now are when you are required to speak. I can show you how to rise quickly above the mass in business—how to jump into prominence and become a leader with the poise and assurance that convinces—how to sell any number of people, from one to a thousand, on the idea you want to put over.

## Free Self Test

I can prove to you, very simply, as I have to thousands of others—that it is possible for YOU to become a master of expression. No matter what your experience has been. By a remarkable self-test that I have devised you can judge for yourself what this training will do for you. And you can make this test absolutely FREE. Do not wait. Fill out and mail the coupon below TODAY. Let me tell you of my amazing special offer, which I may have to withdraw in a short time. Let me send you this self-test that will mean for you the opening of a bigger and better career.

**What This Course Teaches You**  
 How to make after dinner speeches  
 How to sell more goods  
 How to train your memory  
 How to enlarge your vocabulary  
 How to make a political speech  
 How to develop self-confidence  
 How to acquire a winning personality

**North American Institute**  
 3601 Michigan Ave., Dept. 14-26 Chicago, Ill.

**North American Institute**  
 3601 Michigan Ave., Dept. 14-26 Chicago, Ill.

Please send me your free Test information that will enable me to decide for myself whether or not I can become a forceful speaker. Also send me full particulars concerning your course and special limited time offer. I am under no obligation of any kind.

Name.....  
 Address.....  
 City..... State.....

Insure your copy reaching you each month. Subscribe to Science and Invention—\$2.50 a year. Experimenter Publishing Co., 53 Park Place, N. Y. C.

### Motor Hints Relining Brakes BY TOM C. PLUMRIDGE Automotive Expert

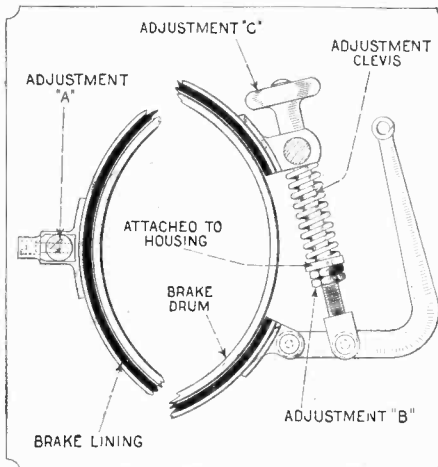

The three adjustments for brake bands are designated above. First turn A to the right until the wheel, when turned by hand, just drags. Then tighten the screw. Next turn nuts at B downward until the band is as close to the drum as possible, without making a wheel drag. Then turn C down in the same manner, being sure that the wheel turns perfectly freely.

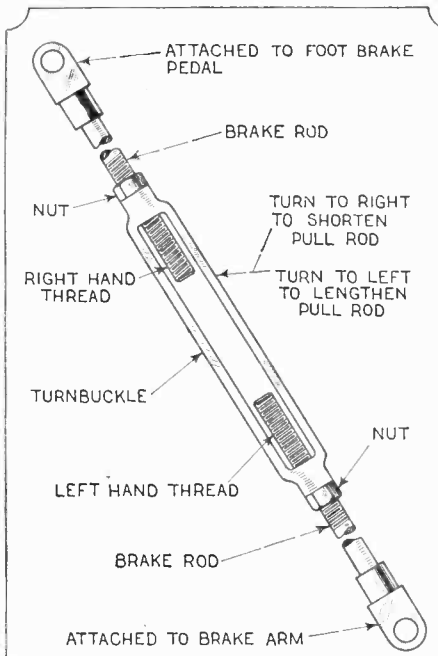

After adjusting the bands, adjust the pull-rod turnbuckles so that the two brakes, right and left, take hold at the same time and brake evenly.

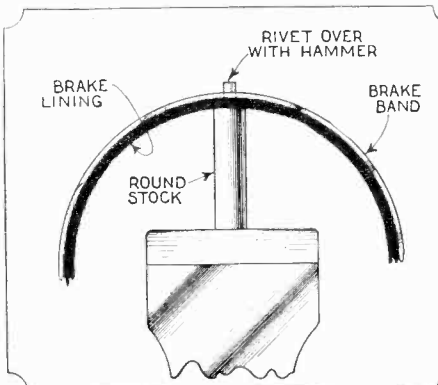

Above is shown the method of riveting a brake band and lining using a piece of solid stock as an anvil.



## MUSIC While You Dine

Here are three popular Radio music selections for the lovers of good music. Each was a prize winner in "RADIO NEWS" Broadcast contest. They are all Radio Selections and are being played by the leading broadcast stations all over the country.

RADIO JAZZ, pictured above, is a lively dance number with a happy lingering theme.

LISTEN IN is a beautiful concert selection with a soft, enchanting melody.

RADIO MARCH is a stirring forceful march for every occasion and is distinctly new and original.

PRICE OF EACH 35c PREPAID

Order your copies today from your dealer or direct from

**CONSRAD CO., Inc.**  
 233 FULTON, STREET  
 N. Y. CITY

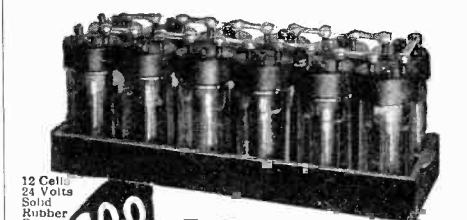

12 Cells  
 24 Volts  
 Solid Rubber Case

## \$4.00 COOD SPECIAL

### INTRODUCTORY PRICE

For a limited time only, and to introduce this new and superior Storage "B" Radio Battery to the Public, we are selling it for \$4.00. Regular Retail Price is \$6.00. You save \$2.00 by ordering NOW. A finer battery cannot be built than the

## World Storage "B" Battery

(12 CELLS—24 VOLTS)

To ten million homes with Radio Sets—and to countless millions of prospective buyers—this WORLD Storage "B" Battery brings a new conception of battery economy and performance. Here is a battery that pays for itself in a few weeks—will last for years and can be recharged at a negligible cost. And you save \$2.00 by ordering now.

**A Superior Battery Equipped With** Solid Rubber Case Has heavy duty 2 1/8 in. x 1 1/2 in. x 1 1/4 in. plates and plenty of acid circulation. Extra heavy glass jars allow ready observation of charge and prevent leakage and seepage of current. It holds its charge, while idle, at constant voltage. You will find this battery a boon to long distance reception. It does away with a great many noises so often blamed on "static." Mail your order today.

### SEND NO MONEY

Just state number of batteries wanted and we will ship day order is received. EXTRA OFFER: 4 batteries in series (96 volts) \$15.00. Pay Expressman after examining batteries. 6 per cent discount for cash in full with order. Send your order NOW and save \$2.00.

**WORLD BATTERY COMPANY**  
 Makers of the famous World Radio "A" Storage Battery  
 1219 S. Wabash Ave., Dept. 83, Chicago, Ill.

**SAVE \$2.00 BY ORDERING NOW!**



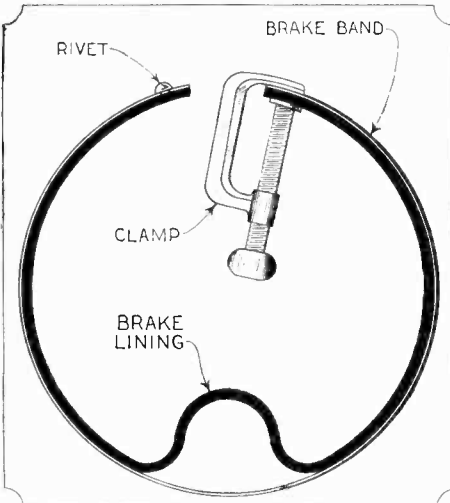

To replace brake lining, cut lining about one inch longer than the band, rivet one end, hold the other with a clamp, and then hammer down the bow in the center until the lining fits the band very snugly.

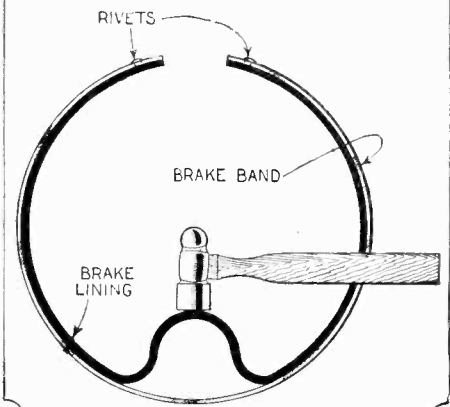
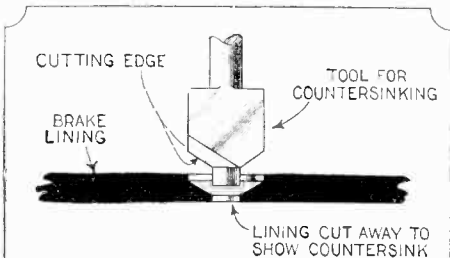

After placing the band, as indicated above, countersink and drill the lining for the rivets. Then rivet the two ends to the band and go through the hammering process again, after which the remaining rivets are installed, as indicated in the bottom sketch on the previous page. Much care must be taken to see that the lining fits the band snugly, and that the two conform in shape all the way around.

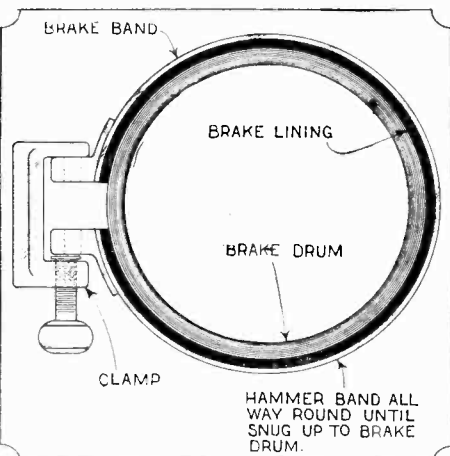

In order to form the new lining to the band, it is often expedient to clamp the new band and lining about the drum which it is to fit when installed. A method of doing this is clearly illustrated above. After clamping the band to the drum, hammer it evenly all around.

“What a whale of a difference just a few cents make!”

— all the difference between just an ordinary cigarette and—FATIMA, the most skillful blend in cigarette history.

**SEND NO MONEY!**

**“INVINCIBLE”**  
Rebuilt Guaranteed  
Standard No. 10  
Self Starter Model  
**REMINGTON**

A real bargain. All late improvements—84 characters, standard type, back spacer, etc. Splendid rebuilt machines that will give years of service. Priced less than one-half the cost of new. Many other standard makes. Time payments if desired. Shipments from nearest of our conveniently located branch stores. Order NOW or write for circular. Resident salesmen wanted.

**5 DAYS FREE TRIAL**

**American Writing Machine Co.**  
Established 1880  
Factory: 458-R Central Ave., Newark, N. J

**YOU TOO CAN PLAY THE HAWAIIAN GUITAR**  
JUST AS THE HAWAIIANS DO!  
**PLAY ALL THE LATEST HITS**

**After Your FIRST LESSON You Will Play a Complete Selection. We Guarantee That--**  
Our method is so simple, interesting and appealing that you begin in your first lesson to learn the famous Hawaiian Folk Song “ALOHA”. Think how happy you will be when you surprise your friends by playing the fascinating Hawaiian Guitar.

**Only Four Motions-- and You Master Them Quickly!**  
In a few minutes you acquire the four motions necessary to play any piece--after that a short period of practice and you will have mastered this weirdly sweet music. Complete course of 62 lessons includes FIVE beautiful Hawaiian Guitar, necessary picks, steel bar, etc. No extras.

**No Previous Musical Knowledge Necessary**  
If you never read a musical note in your life--if you haven't even the slightest knowledge of music, we can quickly and positively teach you to play this wonderfully popular instrument. Don't be just a "listener" when you can easily be the center of interest among your friends. Over 40,000 successful students.

**Just Mail a Post Card for Details** of our remarkable FREE Hawaiian Guitar Offer--simply write: "I am interested" -- but do it today.

**First Hawaiian Conservatory of Music, Inc.**  
Special courses on Violin, Tenor, Piano, Harp, Ukulele and Ukulele.  
Desk 10 - 2338 Broadway (Woolworth Bldg.)  
New York City

**FREE**  
A Beautiful Hawaiian Guitar

Insure your copy reaching you each month. Subscribe to Science and Invention—\$2.50 a year. Experimenter Publishing Co., 53 Park Place, N. Y. C.

# GREER Will Help You Scale the Salary Heights

Increase your Earning Power in the Auto Business

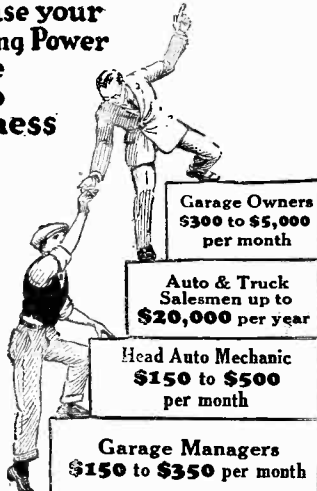

U. S. Census figures show that majority of wage earners earn less than \$1500 per year.

## SPECIAL Training Offer

Don't waste your life away in the low salary class! In 8 weeks I can prepare you to earn \$35 to \$100 per week and more as you progress. I pay railroad fare to Chicago and find you a home. If you need assistance while training I get you an earn-while-you-learn job. I GUARANTEE to get you an automobile job at good pay after you learn. Or you can go in business for yourself.

Special training group now forming. Be one of them. Rates reduced. Time payments. Special kit of tools - 23 pieces - FREE. Every Auto, Truck and Tractor subject covered in actual shop work. Free RADIO COURSE. Day and evening instruction. Choose your own time.

**I Have Trained 47,781 Men**

Of these men, trained by my staff of experts under my personal direction, 30,245 are now in business for themselves.

**MAIL COUPON FOR FREE AUTO BOOK**

This book brings you my entire proposition and pages of valuable automobile information. It is FREE. Get it NOW, while above offers are held open.

---Mail This Today---

**Erwin Greer, President**

Greer College of Automotive Engineering

2024 S. Wabash Ave., Dept. 2303 Chicago, Ill.

Please send me FREE Book "How to Succeed in the Automobile Tractor Business" and special training offer. This request does not obligate me in any way.

Name.....  
Address.....

## Book Review

(Continued from page 507)

less steady stream since Mr. Freud and his school of medical psychologists brought the subject of the human mind before the public. This book, written so as to appeal to the lay mind, begins with a chapter dealing with advertising. In this chapter the matter of mental interest is taken up and dealt with completely. Throughout the remainder of the volume, this interest plays a very important part in Mr. Green's analysis of the mind and its method of working. Of course he follows a more or less regular system of later psychologists in dealing with the human instincts and the relation of these instincts to almost every action of man.

Then, after a discussion on the fundamentals of the mind, he takes up reason and its place in the general scheme of mental activity and passes into suggestion. There are chapters on day dreaming, on bias, forgetting and repression, with some sidelights on symbols and fears. This enumeration of the chief points discussed might lead some to believe that it is merely another attempt at the popularization of the psycho-analysis idea. Such does not appear to be the case to this reviewer. The treatise stays pretty well by established data and accepted dicta and in very few cases gets over into the realm of uncertainty, which is usually so fetching to persons not acquainted with the foundation of psychology and the history of its development. The book is written in a very clear style and need hold no fears for those who do not know the psychological patter. The author makes no attempt to show off his own acquaintance with the subject, but has been guided by a very clear intent to show the public generally its own mind in the working.

**EVERYDAY PSYCHOLOGY FOR TEACHERS.** By Frederick Elmer Bolton. Hard covers, 5" x 8", 443 pages. Published by Charles Scribner's Sons, New York City. Price \$2.50.

As far as we can discern this volume is simply another psychology text fitted for the study of high-school teachers looking to pass the county examination. There is nothing particularly new; no bright and shining example of a new adaptation of the standard laws is given. The book suffers somewhat from the inability of the author to give clearly his ideas. It seems to straggle along and by sheer force of momentum to gather up all the facts included in half a dozen other volumes of the same kind. It is as good as any of them, however, and to those seeking only the practical adaptation of psychology, it will be found sufficient.

**HOME OWNERS' HAND-BOOK.** By Austin C. Lescaurba. Hard covers, 5½" x 7¾", fully illustrated, 494 pages. Published by Scientific American Publishing Co., New York City. Price \$2.50.

A need for a volume such as this one has long been felt. It seems that when a capable writer begins to consider his home his hobby, the result is usually that he strikes off at some particular part of the subject and so writes his treatise on that particular detail which happens to hold his interest. There has not been, recently at least, a volume treating of the home generally, and covering those little points which the architects do not take cognizance of. The present volume deals with the subject from the purchase of the land and the building materials, clear down to upkeep and first aid hints, including a profusion of illustrations and tables which will be found very handy. There is a discussion on the frame, on fabricated and on brick houses; also on houses built with the hollow tile and stucco construction. It gives the reader a pretty thorough idea of building generally, enabling him to become acquainted with various types with their advantages and disadvantages, as well as their adaptation to location and environment, thus saving him much trouble and temper when he pays his first call on the architect. There is also ample discussion of such subjects as excavation, types of roof, painting and paints, plumbing, wiring and built-in features and it has a very good division comparing the various typical heating plants, as well as a chapter on the selection of proper sites and the correlation of the type of building best to be used.

**LIGHT AND COLOR.** By M. Luckiesh. Hard covers, 5½" x 8¾", profusely illustrated, 268 pages. Published by D. Van Nostrand Co., New York City. Price \$3.00.

As has been said possibly half a dozen times or more in these columns, it is always an extreme pleasure to pick up one of Mr. Luckiesh's books. He knows his subject and has a knack of putting it in the best possible way and selecting

## Personal Stationery

200 SHEETS and 100 ENVELOPES Printed with your Name and Address

**\$1.00**

Clear, white bond paper, with envelopes to match. Your name and address printed in beautiful, rich blue ink, on both paper and envelopes, and sent to you postpaid, for only \$1.00. (West of Denver and outside of U. S. \$1.10). If inconvenient to send the money, we will ship C. O. D.

Write name and address plainly.

Money returned if you are not more than satisfied. Order today!

**Elite Stationery Company**  
5030 Main Street  
Smethport, Pa.

## Be An Auto Expert

Learn the Simplex Way!

Let us prepare you at home to become an Auto Expert

Write for SPECIAL OFFER

**SIMPLEX AUTO SCHOOL**

201C-2024 W. Van Buren St.  
Chicago, Ill.



## WANTED—Railway Postal Clerks

**\$133 to \$192 A MONTH**  
MEN-BOYS 18 up  
Travel - See your Country Mail Coupon Today Sure

FRANKLIN INSTITUTE, Dept. N181, Rochester, N. Y.  
Sirs: Send me without charge, (1) specimen Railway Postal Clerk Examination questions; (2) list of U. S. Government jobs now obtainable; (3) send illustrated book, "Government Jobs"

Name.....  
Address.....

illustrations which are compliments to the text. The present volume is one of the most enjoyable which has passed through our hands recently.

It will be found very valuable to advertising men who deal with light and color. The author presents a complete treatment of the selling power of light and color.

**RADIO FOR ALL.** By H. Gernsback, Editor RADIO NEWS. 296 pages. Cloth cover. Published by J. B. Lippincott, Philadelphia, Pa. Price \$2.00.

What the novice in radio needs is a book in which he may obtain all the necessary information for building and operating a radio receiver and one which at the same time, will set forth in simple terms, by means of analogies and illustrations, the how and the why of each piece of apparatus with which he deals. It is only through the agency of such a book as this, that the novice may get the most out of the radio hobby.

Any volume which is to be all that the radio experimenter desires must begin with the very simple elementary principles of the radio art and describe them in such a way that the newly converted experimenter will be able to build, operate, and understand his first set. Then, the text must be so written that having mastered the first details he may be led on into new worlds for his conquering. The book must not be too complicated but must at the same time disclose all the necessary principles and existing phenomena in such manner that the experimenter can make progress with its aid alone until such times as he becomes able through his knowledge and his trials, to stand on his own scientific feet.

The book which forms the subject of this review fulfills the demands set out above. Having been bitten by the radio bug probably the safest step for the inoculated but un-initiated person is the purchase of this volume, since through its good offices the novice may go forth to purchase the parts of his first set, or start its building, with information which makes the difference between success and failure. Further, the book will last him through many cycles of his radio education.

Special features of the book are: Complete list of broadcast stations in the United States and Canada, a resumé of the Radio Act of 1912, how to read radio diagrams and a radio broadcast map of the United States suitable for the radio den.

**THE MOTOR CAMPING BOOK.** By Elon Jessup. Cloth, 227 pages. Published by G. P. Putnam's Sons, New York. Price \$3.00.

Novice and expert alike will find in this volume many practical hints upon the equipment, methods and procedure of motor camping which if followed will pay great dividends through the minimization of a large number of the small inconveniences which are so prone to rise in the regular course of a camping trip. Beginning with a chapter in which the author seeks to impress his readers with the extreme importance of beginning the trip with the proper equipment, he passes into a thorough discussion of the question he has raised in this chapter.

One would judge from the amount of space given to cooking equipment, cooking fires and food boxes that the matter of feeding oneself in proper fashion is of utmost moment even on an automobile camping trip. Of course, there is ample explanation and hints given on the adaptation of sleeping quarters to the equipment of the car and a fair amount of space is devoted to means and methods which the automobile camper may use in times of distress. In the latter part of the book, as is usual in most such volumes, there is a more or less complete review of various motor-camping trails, national parks, laws obtaining in various states as regards foreign drivers and some very valuable hints as to the psychological processes of county constables.

**PIERRE CURIE.** By Marie Curie. Cloth, 242 pages. Published by The Macmillan Co., New York. Price \$2.25.

Here, for the first time, is the story of the discovery of radium as it is told by one of the discoverers. In this volume we find a full account of Mme. Curie's husband's scientific work, a sketch of her own life, and a more or less complete account of her recent trip to America.

The book begins, as all good biographies should, with an account of the early life, inclinations, and schooling of the man who forms the subject of the book. It is the usual thing in biographies, particularly in those written after the death of the man whose life is to be told of, to make some sort of a hero of him. The human race likes the man who in spite of great odds proves a winner. For that reason, if the odds are not discernible in the natural course of events, the transcriber of the biography imports a few for the good of his book; therefore, imagine the pleasure given the reviewer accustomed to reading the most sanguine accounts of scientists' lives each of whom encountered the biggest obstacle known to the realm of natural philosophy and after years and years of weary struggling finally solving it—imagine the pleasure this volume gives when it was discovered to be a straight story written with none of the usual furbelows common to most biographers.

# Radio Headquarters

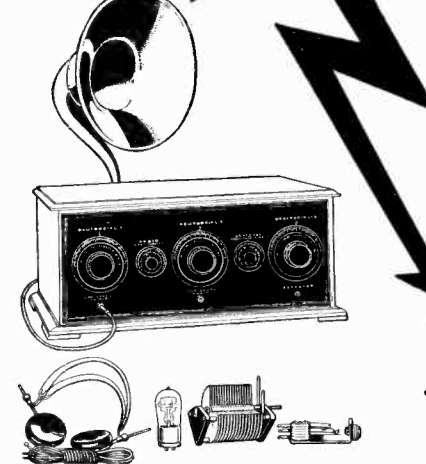

The World's Largest Store is RADIO HEADQUARTERS. Here you can get the famous SILVERTONE neodyne receiving set or the smallest radio part—at the lowest prices in America.

Everybody is interested in Radio. If you would keep in step with the progress that has been made in this greatest of all discoveries, you should have our NEW RADIO Catalog just now off the press.

You can get the latest and best equipment from RADIO HEADQUARTERS. We have everything that anybody needs to enjoy the entertainment, news and education that are waiting to be brought right into your home.

Don't be without the comfort of Radio this fall and winter when reception is so fine.

The World's Largest Store—RADIO HEADQUARTERS—can save you money on everything you need.

Sears, Roebuck and Co. 82R71  
Chicago Philadelphia Dallas Seattle

Send New Radio Catalog.

Name .....

Postoffice..... State.....

Rural Route..... Box No.....

Street and No. ....

## Sears Roebuck and Co.

The World's Largest Store owns and operates Station W.L.S. Wavelength 345 Meters. Tune in

You too can make \$125<sup>00</sup> a week



"I had no experience in selling before going with GOODWEAR. Now I make \$125 a week regularly. I believe that any man who'll work can do the same and would advise every man who wants a fine paying job to write to GOODWEAR."

Peter Birdakis

To earnest men everywhere we offer a wonderful opportunity taking orders for our fine, pure wool suits and overcoats, regular \$55 values, all at the one low price of \$31.75. Our values are so remarkable they sell on sight. You get your commissions in advance, simply take the orders, and we deliver and collect. Our salesmen are making \$50 to \$125 a week and even more.

No experience is needed and spare time will do. We teach and train you, supply the finest selling outfit in America, big 6x9 cloth samples and everything else you need, all packed in a beautiful carrying case. If you want to get into a high-class business, make big money, and be independent, write for full information today. Address Dept. 212

**GOODWEAR Chicago, Inc.**  
West Adams St. at Peoria Chicago

Please send me complete information about your Line and the opportunity you offer.

Name .....

Address .....

Town..... State.....

### How to Get A Position with the U. S. Government

Thousands of appointments are made yearly. Good salaries—short hours—liberal vacations (as much as 30 days in some branches of the service). Positions open now in Washington and other cities and in Alaska, Porto Rico, Hawaii and the Philippines.

"Pull" and influence unnecessary. Common school education sufficient as groundwork for most positions. The International Correspondence Schools will prepare you right at home to pass your Civil Service examination with a high mark.

Mail the coupon to-day for 48-page Free Civil Service booklet.

INTERNATIONAL CORRESPONDENCE SCHOOLS  
Box 6167-D, Scranton, Penna.

Without cost or obligation, please send me a copy of your 48-page CIVIL SERVICE BOOKLET, which tells how I can secure a position with the U. S. Government.

Name .....

Address .....

Insure your copy reaching you each month. Subscribe to Science and Invention—\$2.50 a year. Experimenter Publishing Co., 53 Park Place, N. Y. C.

# Ever buy a wooden nutmeg?

**A** HUCKSTER stopped at great grandmother's door. "Any nutmegs to-day, lady?"

In the tray before him he displayed his wares—big, beautiful nutmegs, and at a ridiculously low price.

Being fond of nutmeg's spicy flavor, and seeing an opportunity to stock up on them to advantage, great-grandmother bought generously.

There was to be rice pudding for supper. Great-grandmother took the golden-brown beauty from the oven and prepared to give it its finishing touch—a sprinkling of nutmeg. Out came the grater and one of the new nutmegs. She scraped and looked puzzled. Scraped again, and looked closer. Sawdust!! The nutmegs were made of wood.

How far from such methods we have traveled in these days of advertised merchandise. The manufacturer of to-day signs his name to what he says about what he makes. He knows that when you buy you will expect the goods to be what he has said. He knows that if he deceives you once, your confidence is gone forever.

Wooden nutmegs never could have been advertised.

Read the advertisements.



*The fire of publicity consumes falsehood—advertised goods are reliable*

## RADIO WRINKLES

EDITED BY  
LEON L. ADELMAN, 2AFS  
Assoc. Mem. I. R. E.

**U**NDER this heading we are going to publish items of interest to everyone who likes to build radio instruments. In order to continue this department it is necessary for our readers to tell us about their latest experiments. Write us a short description of some time- or money-saving kink you have discovered and send it to us along with a few sketches. Our regular prizes will be paid for this material. Be brief and try to put everything in the drawing. Don't be too elaborate. Address "RADIO WRINKLES" editor, care of Science and Invention.

### AERIAL SUSPENSION

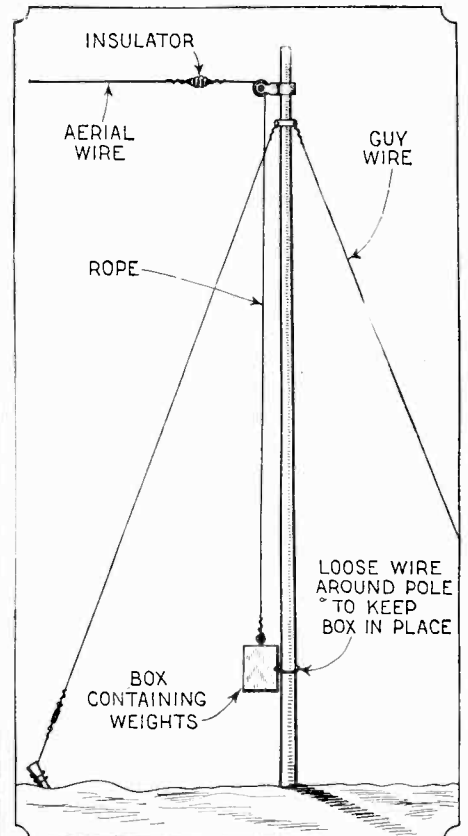

In order to keep the aerial wire taut at all times and yet prevent breaking due to swaying supports, a weighted box is fastened to it.

—Harry R. Lubcke, Reporter No. 1015.

### UNIVERSAL CONTROL

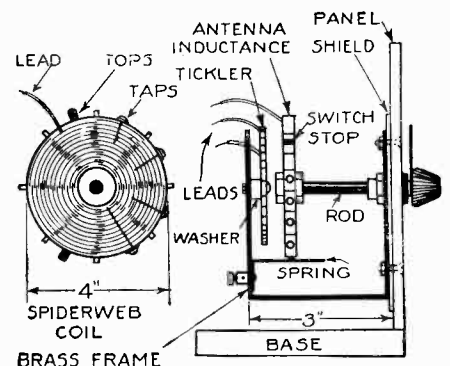

By utilizing the same shaft for varying the coupling and acting as rotary switching arrangement, the selection of a station is the matter of half a second. Wave-length and regeneration are controlled by one hand.

—Paul Huntsinger.



**\$1**

Postpaid with Instructions

SEND FOR YOUR FREE COPY

**TESTED**

**HOOK-UPS**

SUBMITTED BY USERS OF OUR  
WONDERFUL TRANSMITTER  
BUTTON FOR LOUD SPEAKERS  
AMPLIFICATION EXPERIMENTS

**K. ELECTRIC CO.**

15 PARK ROW

NEW YORK

## MAKE MONEY AT HOME

You can earn good money at home in your spare time making show cards. No canvassing or soliciting. We show you how, supply both men and women work at home no matter where you live and pay you cash each week.

AMERICAN SHOW CARD SYSTEM, LTD.  
110 Adams Building Toronto, Canada

### Ranger \$5 a Month

Finest bicycle built—44 styles, colors and sizes. Factory to Rider prices. FREE delivery, express prepaid on 30 Days Free Trial. Cash or easy payments. lamps, wheels and equipment at half usual prices. Send no money. Write today for big catalog, special Factory Bicycle Prices from \$21.50 up; free trial plan and marvelous offers.

**Mead CYCLE COMPANY** Write us today for free catalog  
DEPT C 107 CHICAGO





Are You Proud of Your Radio Receiver?  
Then Keep a Record of Its Performance

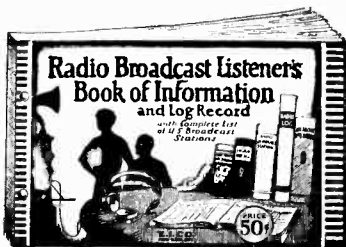

Can you tally offhand how many stations you have received or do you keep a bulky book record somewhere? Here's a handsome Log Record and Book of Information to keep your Radio's performance.

Keep it always in sight, show it to your friends when they visit you. It's a book to be proud of.

Contains 80 pages filled with interesting, useful information and data including complete, accurate list of the broadcast stations in the United States showing time of their operation. Size of book 6x9 1/2" Loose-leaf Binding, two-color printed cover.

It is one of the finest books of the E. I. Company. Order your copy from your Radio Dealer today or write us direct enclosing 50c.

PRICE 50¢ Prepaid

The E. I. Company  
233 Fulton St., New York City

Selling Agents

Conrad

BATTERY SWITCH

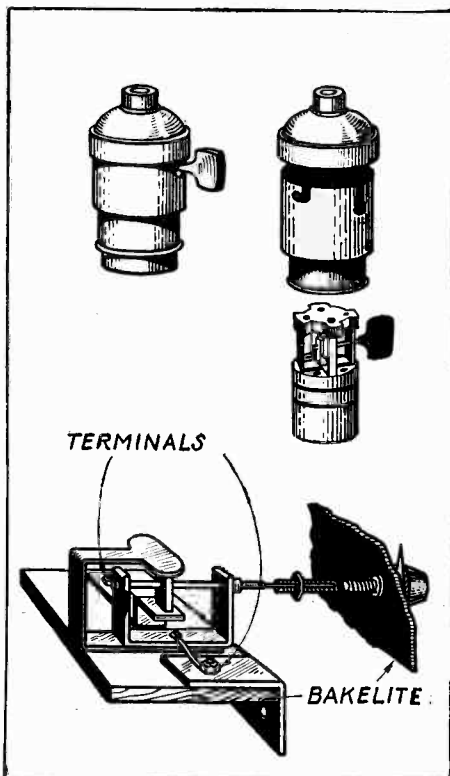

On most radio sets, the "A" battery is turned off by turning the rheostat to its open position. Very often when doing this, the arm is allowed to rest on the last turn of wire, thereby allowing a small amount of current to flow to the filament of the tube. In most cases this current is not enough to produce a visible light, but such a procedure quickly runs down the "A" battery. This possibility can be eliminated by making use of a switch in series with the "A" battery, and an excellent type is illustrated above. To make this, take apart an ordinary socket which contains a key switch. Remove the metal parts of the switch and mount on a small sub-panel as shown in the lower part of the above illustration. Connect the switch by means of an auxiliary shaft to a knob and pointer on the front of the panel.  
—J. T. Garver.

PORTABLE AERIAL

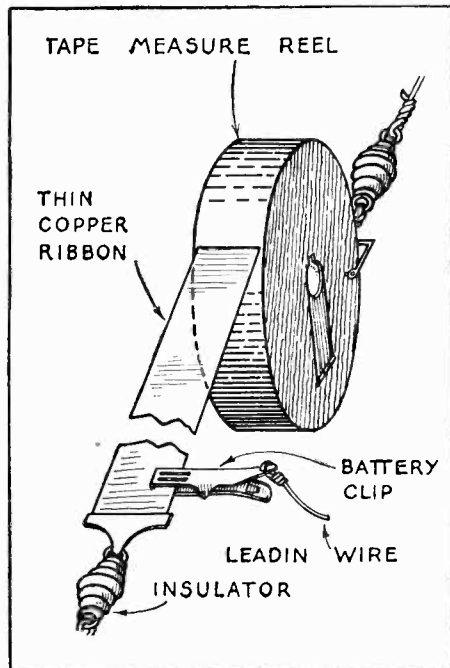

With the summer months almost with us, the radio bug's fancy turns to portable receiving sets and auxiliary apparatus for the same. One of the hardest parts of a portable set to transport is the aerial, but if one makes an aerial from a tape measure reel as shown herewith, his troubles in this respect will be over. The tape measure is removed from the casing and a long strip of extremely thin copper ribbon wound on in place of it. An insulator is attached to the casing and another one to one end of the brass strip. A strong spring clip is used for making connection to the aerial. This can be used in practically any location. —Milton H. Cash, Reporter No. 7152.



Take This Short Cut to Accomplish Your Ambition

The field of Electrical Engineering offers wonderful opportunities for trained men to direct and carry out great industrial and commercial projects. Get a thorough and practical training here in our course of

ELECTRICAL ENGINEERING with B. S. Degree in 3 Years

A faculty of specialists is leading hundreds of ambitious young men to sure success. Why not you? If you are lacking some preparatory studies you can make them up here as you go along. This is an exceptional opportunity to become an electrical engineer in the shortest possible time.

ELECTROTECHNICS

From 1 to 2 years in this course makes you a completely trained electrotechnician—prepared to fill such positions as general plant superintendent, director of construction, superintendent of maintenance, chief draftsman, etc. The Electrotechnician is the man between the Electrical Engineer and the Electrician—a well-paid position and a stepping stone to higher executive work. A grade school diploma or equivalent admits you without examination. New terms open every 6 weeks.

COMMERCIAL ELECTRICAL ENGINEERING IN 1 YEAR

Unparalleled opportunities for brilliant, successful careers in the new field of Commercial Electrical Engineering. To meet the extraordinary present-day demand for trained electrical business men, consulting and efficiency engineers, we offer this thorough, condensed and very practical training, especially adapted to high school graduates.

PRACTICAL ELECTRICITY

In this complete 6 months' Electrical Course—8 hours daily—you can learn house, factory and theatre wiring, testing and meter work, A.C. and D.C. Armature Winding and all necessary mathematics.

A 3 months' course in A.C. and D.C. Armature Winding, or a 3 months' Course in Light and Motor Wiring and Testing is offered to those with limited time and means.

AUTOMOTIVE ELECTRICITY

Electrical specialists who instinctively diagnose and locate automotive electrical troubles command good positions and are well paid. Command the big jobs—specialize in starting, lighting, ignition and storage batteries.

"EARN WHILE YOU LEARN"

If you like, and attend classes half-days and secure, with our assistance, employment for half-days.

ESTABLISHED 17 YEARS AGO

The S. of E. stands absolutely alone in the field of thorough, practical education and in electrical and commercial engineering.

NO NEED OF YOUR BEING WITHOUT AN S. OF E. TRAINING

It does not matter how old you are or what schooling you have had. Students from 16 years up to 50 are in attendance here.

SCHOOL of ENGINEERING of Milwaukee

TEAR OFF COUPON HERE  
Be sure to give your age and education.  
SCHOOL OF ENGINEERING OF MILWAUKEE,  
Dept. S.1.-X924, 415 Marshall Street, Milwaukee, Wis.

Please send, without obligating me in any way, your Free, Illustrated Book "Electricity, and the One Best Way to Learn It in All Its Branches," and further particulars regarding the course I have marked with an "X."

- .... Electrical Engineering.
  - .... Electrotechnics.
  - .... Commercial Electrical Engineering.
  - .... Automotive Electricity.
  - .... Armature Winding.
  - .... Light Motor Wiring and Testing.
  - .... Practical Electricity.
  - .... I am interested in your "Earn While You Learn" Plan.
- Name .....
- Address .....
- City .....
- Education .....



**It's Fun Learning Cartooning This New Easy Way**

IT'S all like a fascinating game—this new home-study method of learning cartooning. You start with the basic principles of cartoon-making. Then you learn the little tricks of originating cartoon-ideas, the secrets of action, expression, and exaggeration. You progress rapidly through serious cartooning, comics, caricaturing, sport and animated cartooning until almost before you realize it you are drawing striking cartoons that SELL. Many students of this method have sold enough work while taking their courses to pay for them many times over!

**Over \$100 a Week**

Learn cartooning this easy way. Never has the demand for cartoonists been so great. Today magazines, newspapers, advertisers and movies use them by the thousands. No matter how poorly you draw now, you can quickly qualify for one of the attractive positions in this fast-growing business. Just think of earning \$3,000 to \$20,000 a year for this work that is play. Successful cartoonists often get \$25 to over \$100 for single cartoons. Then there is the joy of the work itself—the thrill of seeing your own cartoon-ideas in print.

**Send For Free Book**

Mail coupon today for our handsomely illustrated book which is crammed full of up-to-date, interesting facts about cartooning. It gives you an outline of the whole field of cartooning, describes the opportunities for you in this business, and explains in detail all about this new method which makes cartooning so pleasant to learn. Send for it today!



WASHINGTON SCHOOL OF CARTOONING  
Room 269, 1113-15th St., N.W., Washington, D. C.

WASHINGTON SCHOOL OF CARTOONING  
Room 269, 1113-15th St., N.W., Washington, D. C.

Please send me your Free Book on Cartooning, and details of your home-study method.

Name .....  
(Please write plainly)

Address .....

City ..... State .....

If under 16, state age .....

**HEAT Without Coal**

Amazing invention does away with coal or wood. The Instant-Gas Oil Burner sets in firebox of any stove or furnace; burns 96% air and 4% oil. Gives three times the heat of coal, and cheaper. Better cooking and baking.



Installed with out damage to stove in five minutes—to furnace in an hour. Over 100,000 in use. Sold on money back guarantee. Write today for 30 day free trial offer and Free Book, "Scientific Oil Burning." Mention whether for stove or furnace. AGENTS: We pay \$50 a week. Write for free sample offer. International Heating Co., Dept. 3-Y, 117 So. 14th St., St. Louis, Mo.

**ROTARY SWITCH**

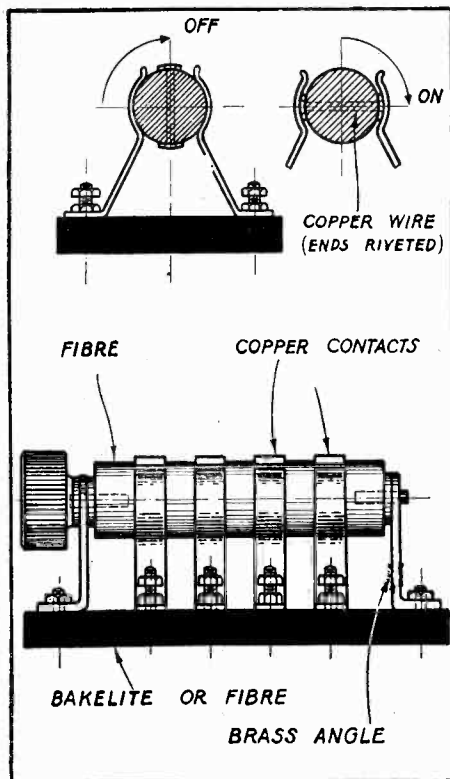

In many places in radio receiving sets and in experimental apparatus, rotary switches are very desirable, but the majority of them are rather difficult to construct. However, the one illustrated above overcomes many of the troubles and can be conveniently mounted. It may be made with any number of contacts, four being shown in the above illustration. Two brass strips bent as shown in the side view of the switch are necessary for each circuit that is to be closed. Heavy copper wire is passed through holes in the fiber rod and riveted on each end so as to form a connection between the two brass strips when turned to a certain position. The fiber rod carrying the contacts may be mounted in any manner such as panel mounting.

—William B. Chambers.

**POSITIVE CONTACT SWITCH**

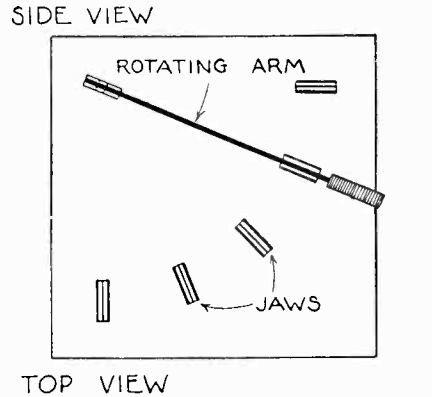
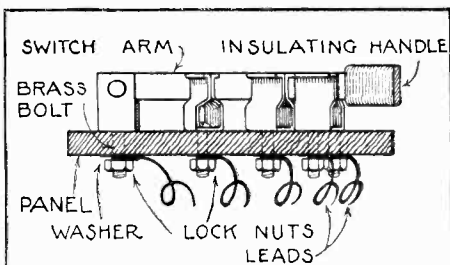

Where a considerable amount of power is to be carried by a switch there are sometimes considerable losses at the contact points. This can be eliminated, when a multi-point switch is to be employed, by making use of the various parts of standard knife switches, as illustrated above. As many switch jaws as there are to be contacts in the completed switch are provided and mounted in a semi-circular form as shown. A switch arm is then journaled and provided with lock nuts so that it can be readily revolved through the required arc without loosening. The rest of the construction is obvious from the above illustration.—George Martin.

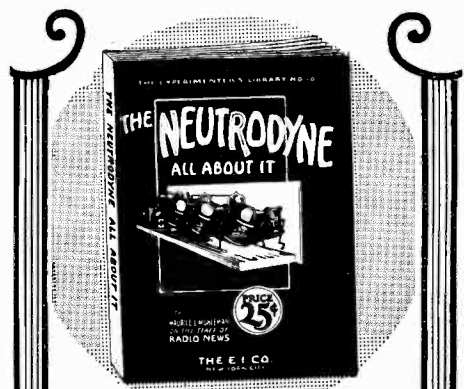

**The Neutrodyne**

**The Circuit of No Regrets**

The Neutrodyne is undoubtedly one of the most popular Radio Receiving Sets in existence today—FIRST because it is highly efficient, obtaining great distance, fine clear reception, and little or no distortion.

SECOND because it does not whistle or howl inherently as do so many receiving sets on the market today, and THIRDLY because it is an extremely simple circuit to construct and has very few parts that can get out of order.

The CONSRAD book No. 10 written by Maurice L. Mulleman of the staff of RADIO NEWS contains complete, practical data, information and notes about the Neutrodyne. This handy book tells How to Construct the Neutrodyne, How to Care for it, and How to Get the Most from it. It tells everything there is to know about this popular circuit.

AT ALL RADIO DEALERS  
Or order direct from us.

PRICE **25¢** PREPAID  
Book No. 10

**E.I. Company**

CONSRAD CO., Selling Agents

233 Fulton St., New York City



**MIRACO GETS 'EM FROM COAST TO COAST**  
PRICE ONLY \$29.50

At rock bottom prices you get the efficiency of sets costing three times as much. Users tell us that Miraco Radio frequency receivers pick up stations from coast to coast. Operate either on dry cells or storage battery. Solid mahogany cabinets—finest workmanship throughout. Order direct or send for bulletin.

Two tube outfit..... \$29.50  
Four tube outfit..... \$54.50

DEALERS — AGENTS — write for proposition quickly—it's a winner.

THE MIDWEST RADIO COMPANY  
809 Main Street Cincinnati, Ohio



**Straightens Shoulders —Increases Pep**  
**THE NATURAL BODY BRACE**—Corrects stooping shoulders, straightens the back, gives the lungs chance for normal expansion, induces proper breathing. Brings restful relief, comfort, energy, and pep. For men and women.

**Costs nothing to try it**  
Write for 30 days free trial offer and free book.  
**NATURAL BODY BRACE CO.**  
Howard C. Rash, Pl. 286 Rash Bldg., Salina, Kansas



# Follow this Man!

**Secret Service Operator  
38 Is on the Job!**

**F**OLLOW him through all the excitement of his chase of the counterfeit gang. See how a crafty operator works. Telltale finger prints on the lamp stand in the murdered girl's room! The detective's cigarette case is handled by the unsuspecting gangster, and a great mystery is solved. Better than fiction. It's true, every word of it. No obligation. Just send the coupon.

# FREE!

**The Confidential Reports  
No. 38 Made to His Chief**

And the best part of it all is this. It may open your eyes to the great future for YOU as a highly paid Finger Print Expert. More men are needed right now. This school has taken men just like you and trained them for high official positions. This is the kind of work you would like. Days full of excitement. Big salaries. Rewards.

# Can You Meet This Test?

Can you read and write? Are you ambitious? Would you give 30 minutes a day of your spare time preparing yourself for this profession? Would you like a life of excitement, thrilling adventures and high pay? Answer yes and I'll show you how to attain all this.

Send the coupon and I'll send the Free Reports — also a wonderful illustrated book telling of the future awaiting you as a Finger Print Expert.

T. G. COOKE, Pres.

**University of Applied Science**  
1920 Sunnyside Ave., Dept. 14-26, Chicago, Ill.

**University of Applied Science**  
1920 Sunnyside Ave., Dept. 14-26, Chicago, Ill.  
Gentlemen—Without any obligation whatever, send me your new, fully illustrated Free Book on Finger Prints and your offer of a FREE course in Secret Service Intelligence and the Free Professional Finger Print Outline.

Name.....  
Address.....  
Age.....

## AERIAL INSULATORS

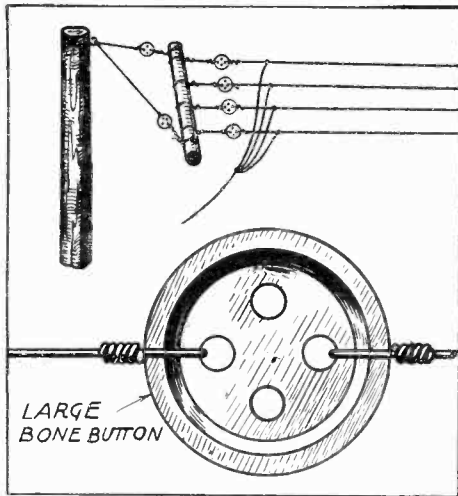

For small aerials where little strain is placed on the insulators, large bone buttons may be used as illustrated above. Two or three may be used in series for better insulation. —Harold Jackson.

## TAP KINK

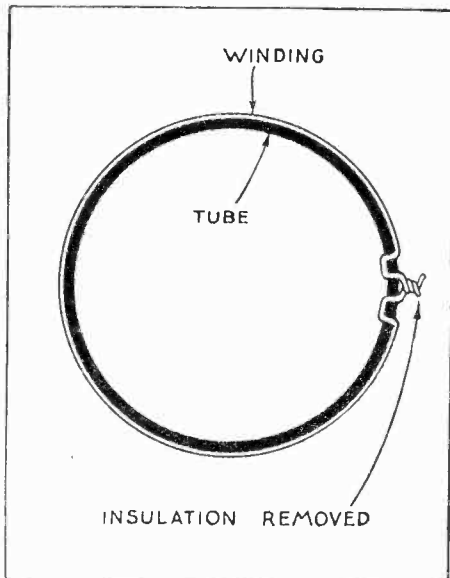

The diagram above shows an excellent method of providing points at which taps are to be taken off a coil. Four holes are drilled in the tube as shown and the wire passed in and out of them after being cut off. The insulation is then scraped from each end of the wire and the ends twisted together. Extension leads to go to switch points may then be soldered to this twisted joint, making sure that the solder sweats into the twisted portion. —W. E. Leach, Reporter No. 3127.

## REINARTZ COIL PATTERN

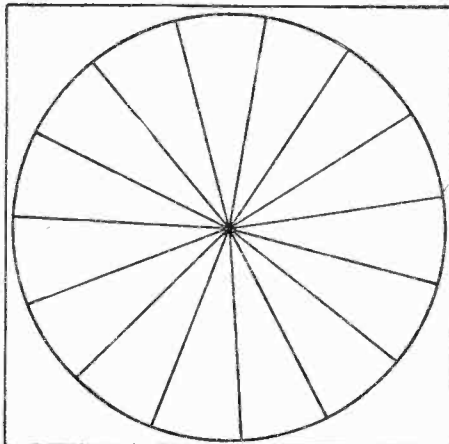

When you are going to construct a Reinartz coil, obtain a disk of wood 2 3/16 inches in diameter and paste the above pattern on one side of it. The points where the diameters intersect the circumference indicate where the thin sticks should be inserted for winding the spiderweb coil. —Daniel R. Axford.

# Learn Electricity

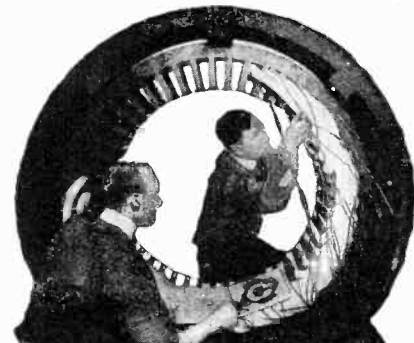

Student winding a Stator in  
The Great School of  
**COYNE**

**Earn \$200 to \$800 a month!**

**New Enlarged Course**

I train you on everything from door-bells to power-plants—everything to make you a \$50 to \$200 a week EXPERT. You get complete PRACTICAL training in Circuits, House Wiring, D. C., A. C., Armature and Stator Winding, Drafting, Auto, Truck and Tractor Electricity, Battery Building and Repairing, and Radio. Everything to make you a thoroughly trained, BIG PAY, Electrical EXPERT.

# CHICAGO

**The Electrical Center of the World**

The whole world of electricity is open to the COYNE trained Electrical Expert. Come to Chicago—the Electrical Center of the World. I pay your fare. Get your training at COYNE—the oldest, largest and best school of practical electricity in the country—endorsed by Electrical Industry. I do not offer a number of individual courses—I give you just one complete course so that you will be an Electrical Expert capable of commanding big pay. You can become an Expert and get big money in ANY branch of electricity if you come to COYNE.

# Learn in 12 Weeks!

**NOT A CORRESPONDENCE SCHOOL**

No books or useless theory. I train you on the greatest outfit of electrical apparatus of any institution in the country. I give you FREE complete Radio and Automotive courses. I also give you FREE a Life Membership which enables you to stay longer if you want or to come back at any time and take up any new work which is constantly being installed to keep my school the most modern at all times.

**You Don't Need Education or Experience** COYNE gives you education and experience by actual work—that's why you don't need education or experience to start with.

# Earn While You Learn!

I help students to secure jobs to earn a good part of their living expenses while studying.

# Send Coupon Now

Don't delay a minute—send that coupon right now for my big free catalog and full particulars of special offer. ACT NOW!

**Free R. R. Fare to Chicago**  
Come to Chicago—the country's greatest summer resort city—and be ready for BIG MONEY in 12 weeks!

**COYNE**  
Electrical School  
Endorsed by Electrical Industry

1300-1310 W. Harrison St., Dept. 533-6 Chicago

**Coyne Electrical School, Dept 533-6**  
1300-1310 W. Harrison St., Chicago  
Mr. H. C. LEWIS, Pres. Dear Sir:—Please send me free your big new catalog and full particulars on free railroad fare offer and two free courses.

Name.....  
Address.....



Write for your free copy of

# Ward's Radio Catalogue



A Valuable 68-Page Reference Book on Radio—a Market Place for the Best in Sets and Parts

We want you to have a copy of Ward's new Radio Catalogue. You will find it to be an encyclopedia of information on Radio, the liveliest topic of the day. It contains a new Radio map—diagrams of the best hook-ups—descriptions of complete sets, and standard parts for building sets.

**Headquarters for Radio**

Montgomery Ward offers you all types

of Radio Equipment at a saving. We sell direct to you only merchandise of highest quality. Everything you buy from us, carries our 52-year-old guarantee—"Your money back if you are not satisfied."

**Enjoy the Long Winter Evenings**

Every form of entertainment can be brought into your home by Radio. Keep in touch with the world—Sports—Election Returns—Dance Music—Speeches—Sermons—Current Events—you can enjoy them all by Radio.

Write today for your copy of this complete Radio Catalogue. Address our house nearest you: Dept. 40-R.

## Montgomery Ward & Co.

The Oldest Mail Order House is Today the Most Progressive

Chicago Kansas City St. Paul Portland, Ore. Oakland, Cal. Ft. Worth

### A CONVENIENT LOOP

APPROXIMATELY 100 FEET NO 26 COVERED COPPER WIRE SPACED 1/8" APART

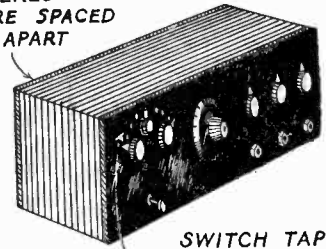

SWITCH TAPPING LOOP EVERY HALF TURN ON LAST THREE TURNS

WHEN THE TOP OF THE CABINET IS HINGED THIS METHOD OF WINDING MAY BE USED:

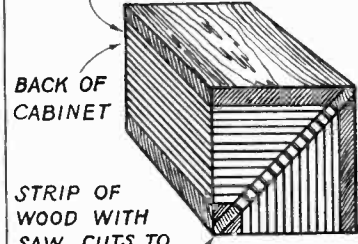

BACK OF CABINET

STRIP OF WOOD WITH SAW CUTS TO HOLD WIRE

Very often the location of a loop aerial to be used in connection with a radio receiving set causes trouble. The usual types of loops are rather cumbersome and take up a lot of room. They can be done away with by winding the loop around the cabinet of the set itself. If the latter is of the type that slides from the cabinet, the loop may be wound around the cabinet as shown in the upper part of the above illustration. Either silk or cotton covered wire can be used for this work. The loop may also be tapped and connections made to switch points. This is of great assistance in tuning. If the top of the cabinet is hinged, the loop may be wound on the bottom and across the back of the cabinet as shown in the lower part of the above illustration. Slotted wooden strips will be necessary in this case to hold the wire in position. In any event, small rubber headed tacks should be placed in the four corners of the bottom of the cabinet so that the wire cannot rub on the table. —Abbott D. Corkum, Reporter No. 5275.

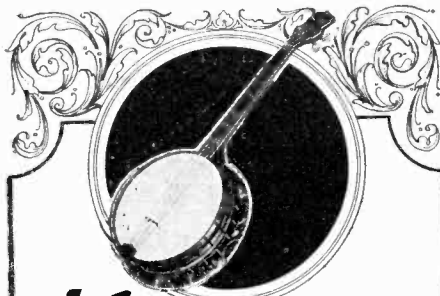

play for profit or just for fun

THE new Gibson Mastertone banjo fills your leisure hours with the pleasure of music you like—as you play it yourself. So easy to learn, you master it quickly, because of exclusive Gibson features. Play professionally, if you choose, whole or part time, and increase your income. Banjo players are in great demand. Write for details of Free Trial; Easy Payments on any Gibson banjo, mandolin, mandola, mando-cello or guitar.



Wm. Crookes, Hartford, Conn. banjoist, uses and endorses the Gibson. Let us tell you of the opportunities opened by the new cycle in music which stresses stringed instruments.

GIBSON, INC. 910 Parsons St., Kalamazoo, Mich. **Gibson** STRINGED INSTRUMENTS World's Leading Manufacturers

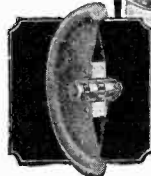
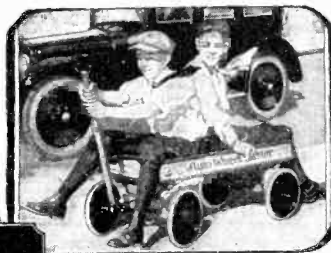

You can have disc wheels, too

You can have steel disc wheels on your coaster wagon, just as Dad has on his car. And with over-sized rubber tires, too—which ride easily and as swiftly as a racer, or with steel-tired disc or wood spoke wheels.

## Auto-Wheel

Exceptionally sturdy because supports under box are hard maple—will not collapse, rust or weaken. Actual tests prove hardwood supports better than steel! Also self contained roller bearings, mortised joints, hound brace, hand brake, and special hub cap and locking pin.

Write for catalog showing all models of the Auto-Wheel and Auto-Cart. A year's subscription to the "Auto-Wheel Spokes-man" FREE if you send names and addresses of three dealers in your town.

AUTO-WHEEL COASTER CO., Inc. North Tonawanda, N. Y.

### PHONOGRAPH ATTACHMENT

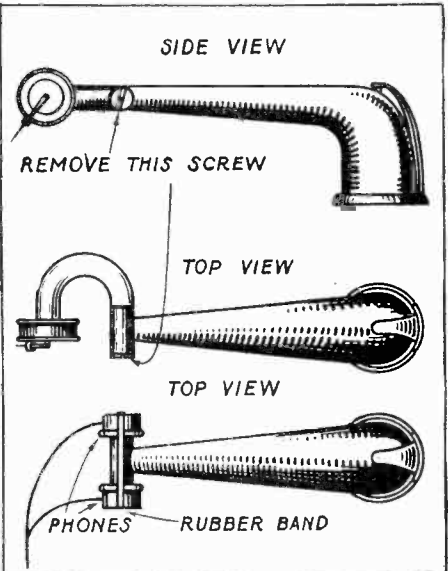

If the radio bug is lucky enough to have a phonograph, the tone arm of which is constructed as shown above, he can attach his phones thereto in a very few seconds. All he will have to do is to remove the screw shown, whereupon the reproducer and the curved arm can be removed. The phones can then be placed one on either side of the resulting tube and fastened thereto by means of a heavy rubber band as shown in the lower part of the above illustration. —Paul F. Bryant.



# How to Finish Your Radio Cabinet



If you have a hobby for making radio cabinets, furniture, porch swings, etc., you will find our Book especially interesting for naturally you want to give your handiwork a beautiful finish. Our book is the work of experts—beautifully illustrated in color. Use coupon below.

## JOHNSON'S WOOD DYE

Johnson's Wood Dye is manufactured in seventeen beautiful shades for the artistic coloring of all wood. It is very easy to apply—dries in four hours and will not rub off or smudge—penetrates deeply, bringing out the beauty of the grain without raising it.

### FREE 25c Book on Wood Finishing



It is an authoritative manual on finishing all wood—hard or soft—old or new. It is the work of experts—profusely illustrated. Gives covering capacities, includes color charts, tells what materials to use, etc.

Ask for a FREE copy of the Johnson Book on Wood finishing at any store displaying the service department sign shown at right. If no store in your community has a Johnson Service Department—fill out and mail coupon and we will promptly send you the book FREE and postpaid.



S. C. JOHNSON & SON, Dept. S. I. 9  
RACINE, WIS. (Canadian Factory—Brantford)

Please send me free and postpaid your Instruction Book on Wood Finishing and Home Beautifying.

My Dealer is .....  
 MY NAME .....  
 MY ADDRESS .....  
 CITY & STATE .....

### ROTOR SUPPORT

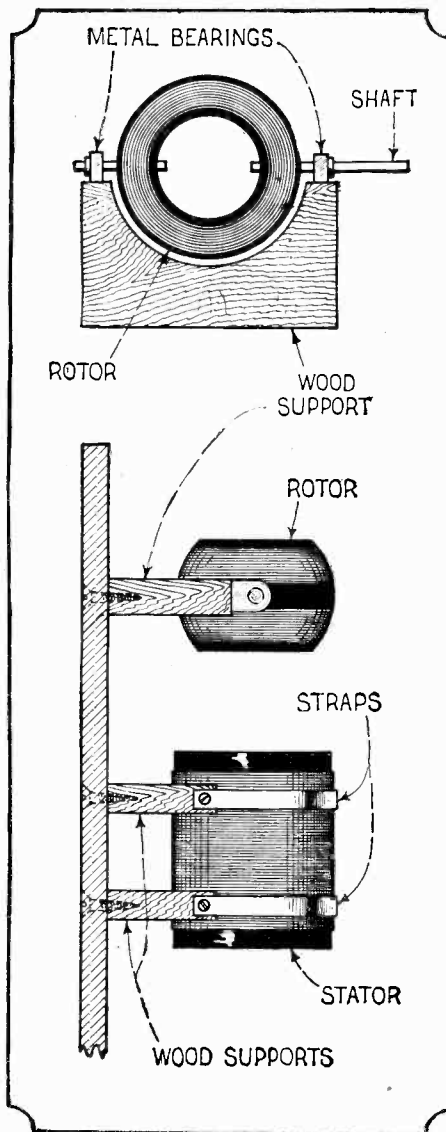

When it is desired to have very loose coupling between the rotor and the stator, trouble is often experienced in mounting the rotor. One of the simplest methods of doing this is to cut a saddle from three-quarter inch wood as shown in the upper part of the above illustration. The rotor is then mounted, any handy type of bearings being used. Saddles of the same style may be used for mounting the stator as illustrated. The rotor mounting could be so arranged that it could be moved nearer to or further from the stator, thereby giving greater flexibility. —Russell Erwin.

### MULTIPLE DETECTOR

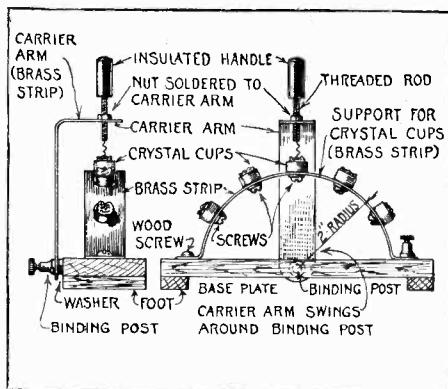

For experimental purposes, an excellent multiple crystal detector may be constructed as shown above. The cups containing the crystals are rigidly fixed on a semi-circular support while the arm carrying the cat whisker may be revolved through a semi-circle. In this way several different types of crystals may be tested out against each other without having separate detector stands. Connections are made to the two binding posts shown. —C. A. Oldroyd.

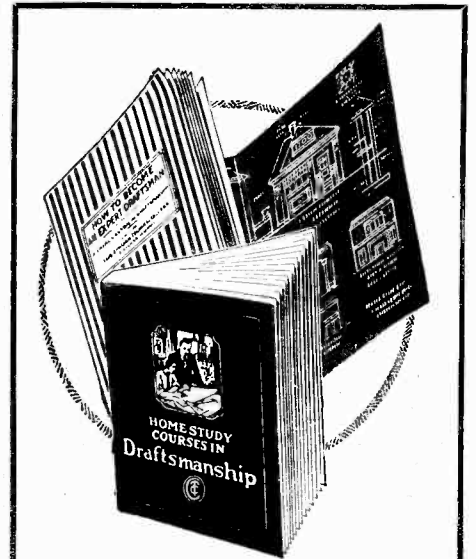

## FREE Trial Lesson DRAFTING

The coupon below brings this Free Trial Lesson, prepared by the Chicago Tech. experts. Learn from it, before you pay out a penny, how well qualified you are to take up Drafting. While other schools require enrollment and payment of fees at once, Chicago Tech. sends you this lesson first and also information on how to get into the high salaried profession of Drafting by utilizing your spare hours.

### Big Jobs Waiting

Become an expert Draftsman and you can "write your own ticket." Chicago Tech. training enabled Rex Cary to make 4 times his former salary; A. S. Ross soon had a salary increase of \$225 a month and J. A. DeCosta who was a laborer became manager through the same training. Your opportunity is as good as theirs. All you need is this training.

### Train at Home

You can get this training without leaving your present position. The Chicago Tech. experts will teach you by mail, giving you the knowledge that will make your services always in demand by big industries. No useless theories, no dry text books to study. You work on practical problems and learn the ways of successful high-salaried Draftsmen.

## FREE Drawing Outfit

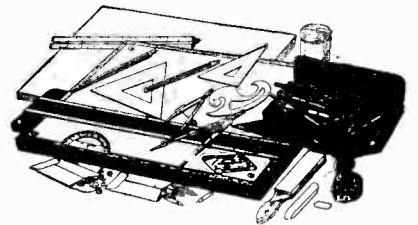

Home study students receive this complete professional Drawing Outfit (retail price \$25) without extra charge—or credit for fees if they have outfits.

### Send the Coupon

Mail the coupon and get the Free Trial Lesson—also catalogs and full information about the Chicago Tech. Method of teaching Drafting by mail. No cost to you—no promise or obligation on your part. Send today.

### CHICAGO TECHNICAL COLLEGE

Dept. 945, Chicago Tech. Bldg.,  
118 East 26th St., Chicago, Ill.

Without cost or obligation on me please send instructive matter about opportunities in line I have marked with "X."

( ) Drafting. (The Big Salary Course.) No experience necessary. Free Lesson sent now.  
 ( ) Building Trade Course. For men in the building lines.

Name .....  
 Address .....  
 City .....  
 State .....



## The only man who could talk to the Superintendent

"SOON after I began studying," a student wrote to us the other day, "we had a change in management at our plant. I certainly was glad then that I had decided to study in my spare time. For, thanks to my I. C. S. course, I was the only man in the organization who could talk to the Superintendent in his own language. As a result, I was promoted over men who had been here from ten to twenty years. My salary has been increased 90 per cent in the last ten months."

THAT'S a true story of what just one I. C. S. student has done. There are thousands of others. Every mail brings letters from men and women telling of promotions and increases in salary due directly to spare-time study.

One hour a day, spent with the I. C. S. in the quiet of your own home, will prepare you for success in the work you like best. Yes, it will! Put it up to us to prove it.

Mail this Coupon To-day

INTERNATIONAL CORRESPONDENCE SCHOOLS  
Box 6162-D, Scranton, Penna.

Without cost or obligation on my part, please tell me how I can qualify for the position or in the subject before which I have marked an X:

### BUSINESS TRAINING COURSES

- |  |   |
|--|---|
| <input type="checkbox"/> Business Management                     | <input type="checkbox"/> Salesmanship           |
| <input type="checkbox"/> Industrial Management                   | <input type="checkbox"/> Advertising            |
| <input type="checkbox"/> Personnel Organization                  | <input type="checkbox"/> Better Letters         |
| <input type="checkbox"/> Traffic Management                      | <input type="checkbox"/> Show Card Lettering    |
| <input type="checkbox"/> Business Law                            | <input type="checkbox"/> Stenography and Typing |
| <input type="checkbox"/> Banking and Banking Law                 | <input type="checkbox"/> Business English       |
| <input type="checkbox"/> Accountancy (including C.P.A.)          | <input type="checkbox"/> Civil Service          |
| <input type="checkbox"/> Nicholson Cost Accounting               | <input type="checkbox"/> Railway Mail Clerk     |
| <input type="checkbox"/> Bookkeeping                             | <input type="checkbox"/> Common School Subjects |
| <input type="checkbox"/> Private Secretary                       | <input type="checkbox"/> High School Subjects   |
| <input type="checkbox"/> Spanish <input type="checkbox"/> French | <input type="checkbox"/> Illustrating           |

### TECHNICAL AND INDUSTRIAL COURSES

- |   |  |
|---|--|
| <input type="checkbox"/> Electrical Engineering                           | <input type="checkbox"/> Architect                                   |
| <input type="checkbox"/> Electric Lighting                                | <input type="checkbox"/> Architects' Blue Prints                     |
| <input type="checkbox"/> Mechanical Engineer                              | <input type="checkbox"/> Contractor and Builder                      |
| <input type="checkbox"/> Mechanical Draftsman                             | <input type="checkbox"/> Architectural Draftsman                     |
| <input type="checkbox"/> Machine Shop Practice                            | <input type="checkbox"/> Concrete Builder                            |
| <input type="checkbox"/> Railroad Positions                               | <input type="checkbox"/> Structural Engineer                         |
| <input type="checkbox"/> Gas Engine Operating                             | <input type="checkbox"/> Chemistry <input type="checkbox"/> Pharmacy |
| <input type="checkbox"/> Civil Engineer                                   | <input type="checkbox"/> Automobile Work                             |
| <input type="checkbox"/> Surveying and Mapping                            | <input type="checkbox"/> Airplane Engines                            |
| <input type="checkbox"/> Metallurgy <input type="checkbox"/> Mining       | <input type="checkbox"/> Agriculture and Poultry                     |
| <input type="checkbox"/> Steam Engineering <input type="checkbox"/> Radio | <input type="checkbox"/> Mathematics                                 |

Name.....  
Street..... 3-6-24  
Address.....  
City..... State.....

Occupation.....  
Persons residing in Canada should send this coupon to the International Correspondence Schools Canadian, Limited, Montreal, Canada



## FORD RUNS 57 MILES ON GAL. of "GAS"

An automobile runs 57 miles on a gallon of gasoline by using an automatic device which was installed in less than five minutes. The inventor, Mr. John A. Stransky, 19-1st St., Pukwana, S. Dak., wants agents and is willing to send samples at his own risk. Write him today

## STAMMER NO MORE

Kill the fear of stammering. Re-education the key. The widely famed Hatfield Method fully outlined in an accurate, dependable, worthwhile book—"HOW TO STOP STAMMERING" in has inspired thousands. Free copy today.

THE HATFIELD INSTITUTE, 109 N. Dearborn, Chicago, Ill.

### NOVEL SWITCH

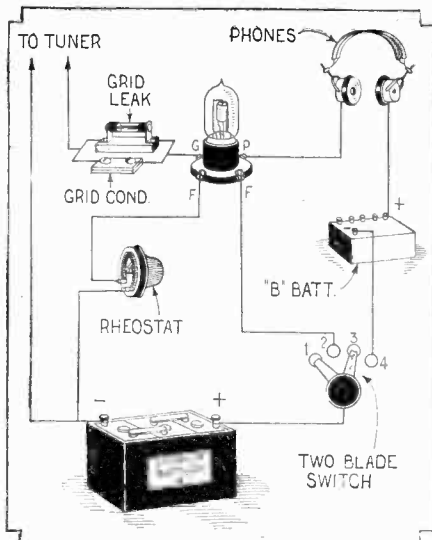

By means of the simple two blade switch shown connected up in the diagram above, the "A" as well as the "B" battery circuits are opened or closed with one movement of the switch knob. —Verl A. LaVaway.

### SIMPLE WAVE TRAP

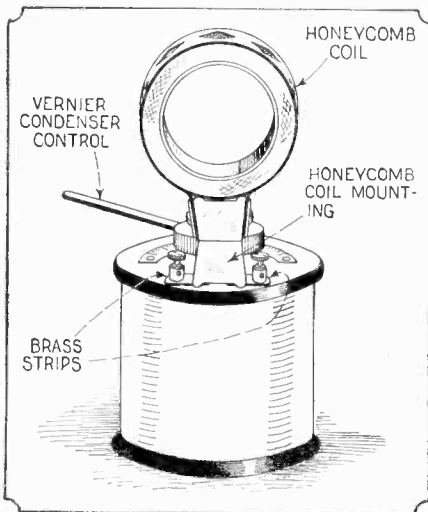

Anyone possessing an old closed type variable condenser and honeycomb coil can readily make this wave trap. A 35-turn honeycomb coil base is secured to the top of the condenser with screws, and each terminal of the H.C. coil connected to the terminals of the condenser. —Nestor Barrett, Reporter No. 6425.

### ANTI-TWIST PHONE CORD

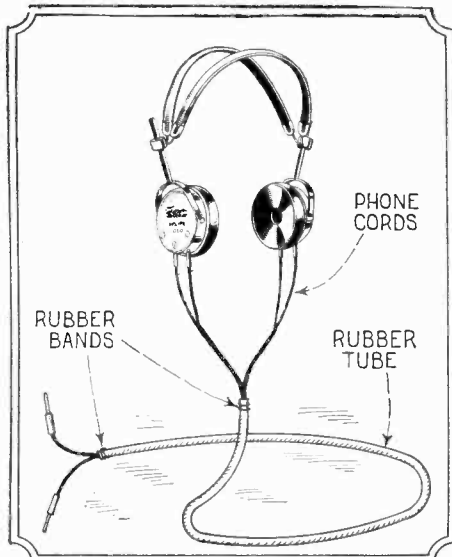

The tendency of phone cords to twist may be overcome by slipping a rubber tube over the cord, as shown. A small rubber band is doubled and slipped over each end of the rubber tube. —B. G. Switzer.

## "ULTRA" Radio Reception



## The ULTRADYNE

The Ultradyne is the "ULTRA," The finest in High Powered 8 Tube Radio Receivers. It is designed by Robert E. Lacault, of the Staff of RADIO NEWS. Using the famous system of Modulation. It is one of the most consistent Receivers in getting signals from coast to coast.

You can build your own ULTRADYNE at home using the CONSRAD Pattern No. 10. This pattern contains a simple four page pamphlet of instruction, that anyone can follow and an extra large blue print 30 x 18 in. showing the complete wiring diagram and panel layout. The entire pattern is enclosed in a handsome 9 x 12 in. two-color folder.

PRICE **25¢** Prepaid  
Pattern No. 10  
How to make the Ultradyne

The Consrad Company  
233 Fulton St., New York City

# Consrad

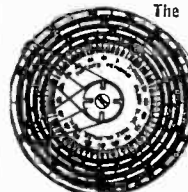

The Midget "FIVE-ONE" Slide Rule a combination Mannheim, Log-Log, Add and Subtract, Polymetric and Binary Slide Rule. Will instantly add, subtract, multiply and divide any combination involving whole numbers, fractions, decimals and mixed numbers. Gives every root and power of every quantity. Graduations printed on metal coated with white celluloid and are grease and waterproof. While the most versatile calculator ever invented, operation is simple and easily understood. Diameter 1 1/2". Price with 16-page Instruction Book, \$1.50. Leatherette carrying case 50c extra. Catalog free. Your money back if you are not satisfied.

GILSON SLIDE RULE COMPANY, NILES, MICH.

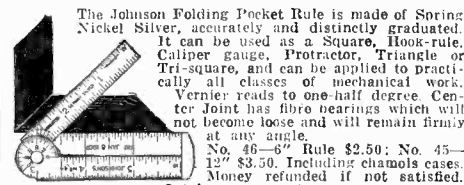

The Johnson Folding Pocket Rule is made of Spring Nickel Silver, accurately and distinctly graduated. It can be used as a Square, Hook-rule, Caliper gauge, Protractor, Triangle or Tri-square, and can be applied to practically all classes of mechanical work. Vernier reads to one-half degree. Center Joint has fibre bearings which will not become loose and will remain firmly at any angle. No. 46-6" Rule \$2.50; No. 45-12" \$3.50. Including chamolux cases. Money refunded if not satisfied. Catalog on request.

E. P. JOHNSON RULE MFG. CO.  
565 W. Washington Blvd., Chicago

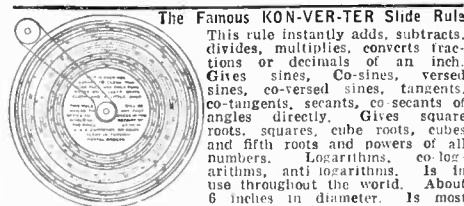

The Famous KON-VER-TER Slide Rule This rule instantly adds, subtracts, divides, multiplies, converts fractions of decimals of an inch. Gives sines, co-sines, versed sines, co-versed sines, tangents, co-tangents, secants, co-secants of angles directly. Gives square roots, squares, cube roots, cubes and fifth roots and powers of all numbers. Logarithms, co-logarithms, anti-logarithms. Is in use throughout the world. About 6 inches in diameter. Is most complete rule of its kind ever made to sell at a popular price. 20 page book of instructions and box for each rule. DELUXE MODEL White Ivory Celluloid, \$3.00 postpaid. We also handle other types of slide rules, engineering handbooks and equipment. J. C. Hamilton, 7 Water St., Boston, Mass. Dept. B.

# YOU CAN LEARN NEWSPAPER WORK

Experienced Editor Will Teach You  
How to Become a  
Reporter

FASCINATING WORK--GOOD PAY

Only a Few Months' Work Required  
To Qualify You for a  
Better Position

Regular reporters earn from \$40 to \$125 a week. Good deskmen on a daily paper are paid from \$60 to \$100 a week. A "Star" Reporter can command his own salary. Hundreds of ambitious men and women enhance their income materially by corresponding for newspapers or writing for magazines in their spare time.

## We Will Teach You at Home

We can develop your talent for writing and lead you into this well paying profession. Our Practical Course in Journalism was personally prepared by Henry J. Brockmeyer, for 13 years on the Editorial Staff of the N. Y. Evening Post. Mr. Brockmeyer has trained hundreds of men and women, many of whom have, under his guidance, developed into front rank reporters.

Mr. Brockmeyer's course will teach you what it would take years of actual newspaper work to learn. It consists of six comprehensive lessons just brimful of everything a reporter must learn. The following are only a few of the subjects covered.

Starting in Journalism. What is a Newspaper? What is News? Start and Finish of a News Story. Technical Terms. The Type Point System. Styles of Type, Proof Reading. Capitalization and Punctuation. A Late Fire Bulletin. Court Stories. Libel Laws, Copyright. Hints to Reporters. Personal Conduct. Re-Writing and Condensing Stories. Paragraphs and Short Items. Good and Bad Styles. Broadening the Vocabulary. Aids to Good Style. Special Stories. Suggestions for Stories. Rhetoric. Preparing Your Story. Don'ts for Writers. Office Organization. Syndicated Matter. Business Office. Mechanical Department. Hints for Headline Writers. The Make-Up. The Country Correspondent, etc., etc.

## Use Coupon—Save 50%

Although the price for the entire course is \$10, entitling the students to full consulting services directed by Mr. Brockmeyer personally, we will accept enrollments, if the coupon below is used before Oct. 20, at \$5—exactly half price.

## Five Days' Trial

Just pin a check, money order or five dollar bill to the coupon below and mail. Then take five days after the course arrives to decide whether you want to keep it. If not, return it at our expense, and your money will be immediately refunded.

THE PRESS GUILD, Inc., 66-S West Broadway, N. Y.

THE PRESS GUILD, Inc. (Expires Oct. 20, 1924)  
66-S West Broadway, New York City.

Enclosed find \$5 for which you are to ship me at once, prepaid, Henry J. Brockmeyer's complete course in Practical Journalism with the distinct understanding that if I return the course in five days my full \$5 will be refunded and no questions asked.

(Name) .....  
(Address) .....  
(City) ..... (State) .....

## "B METAL" DETECTOR

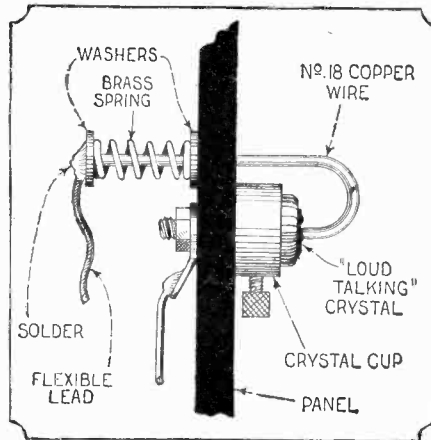

A detector that will stay put and is very efficient for "B metal" and other loud-talking crystals, that require a large contact and heavy pressure, is shown in the drawing. The cat whisker is made of No. 18 hard drawn copper wire and has a blunt contact point. A stiff brass spring is used to supply the proper tension. —Bunnie Chambers, Reporter No. 2254.

## QUICK THROW AERIAL SWITCH

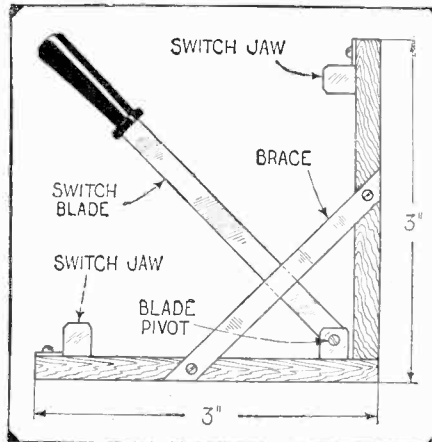

With the ordinary double-pole, double-throw knife switch, such as is frequently used for switching from "send" to "receive," there is too much delay and movement required in manipulating this appliance. The drawing herewith shows how the switch may be rebuilt, so as to be thrown in half the time and with much less physical effort. —W. R. Daniels.

## USING "B" BATTERY AS "C" BATTERY

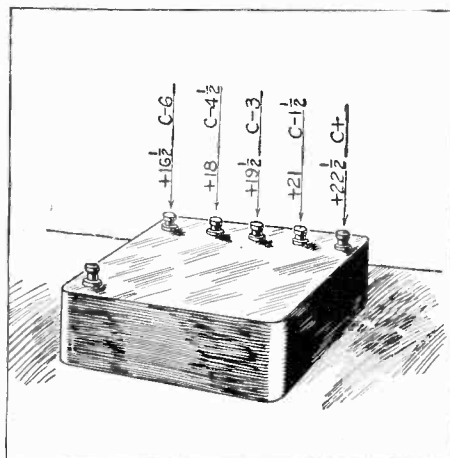

The picture above shows how to connect up wires to an ordinary "B" battery so as to be able to obtain the desired potentials for "C" battery service. The 22 1/2 volt terminal of the "B" battery is used as the positive terminal of the "C" battery. —John Bruen.

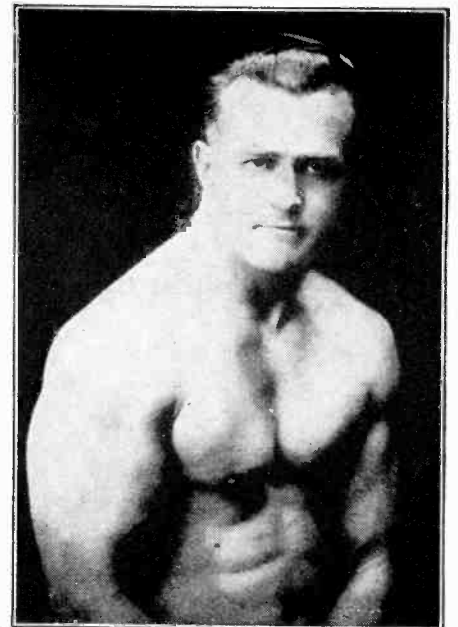

EARLE E. LIEDERMAN  
The Muscle Builder

## If You Had A Face Like A Monkey

you would try to change it. But just because you wear a pair of pants and a coat to cover the rest of your body you don't seem to care a rap what you look like from the neck down. Come on out of it fellows. Get wise. Don't you know you can't keep this up? It's only a few years and ZOWIE it's too late. Your body is clogging up with all kinds of poisons. The only way to get rid of these poisons is to drive them out. Exercise wears off the worthless tissue, the blood carries it to the surface and then you sweat them out through your pores. That's simple enough. But if you don't—your blood will absorb all this poison and soon you're nothing but a human wreck.

## I MAKE STRONG MEN

No one likes to look at a narrow-shouldered, flat-chested dyspeptic. Such a man is no good to himself or anyone else. It's the strong, robust, energetic man who gets ahead. He is admired and sought after in both the business and social world. No matter where you find such a man, he is the whole works. Come on then—snap into it. Right now—this minute. This is your day. This message was meant for you or you wouldn't be reading it. I'm all set and waiting for you, and oh boy! what I do to you will sure open your eyes. I'm going to push out that chest of yours, broaden your shoulders and put a pair of arms on you that will carry the kick of a mule. I'm going to build up your whole body with good, solid muscle. I'm going to strengthen every vital organ and shoot a quiver up your old spine that will make you feel like a jack rabbit.

## I CAN DO IT

Just because a man is built like an ox doesn't mean he can show you how to be the same way. There are plenty of strong men today who couldn't tell you how they ever did it. I made my reputation teaching and building others. And my biggest achievements have been made during the past year—not ten years ago. My instructions are modern and up-to-date. When you come to me your success is assured. I don't promise strength—I guarantee it. Are you ready? Let's go.

Send for my new 64-page book  
"MUSCULAR DEVELOPMENT"  
IT IS FREE

It will show you what I have done for others and what I guarantee to do for you. It contains forty-three full page photographs of myself and some of my many prize-winning pupils I have trained. Some of these came to me as pitiful weaklings, imploring me to help them. Just look at them now and you will marvel at their splendid physiques. This book will prove an impetus and a real inspiration to you. It will thrill you through and through. All I ask is 10 cents to cover the cost of wrapping and mailing and it is yours to keep. This will not obligate you at all but for the sake of your future health and happiness, do not put it off. Send today—right now before you turn this page.

EARLE E. LIEDERMAN  
Dept. 209, 305 Broadway, New York City

EARLE E. LIEDERMAN,  
Dept. 209, 305 Broadway, New York City

Dear Sir: I enclose herewith 10c for which you are to send me, without obligation on my part, whatever copy of your latest book "Muscular Development."

Name .....  
Street .....  
City ..... State .....  
(Please write or print plainly)

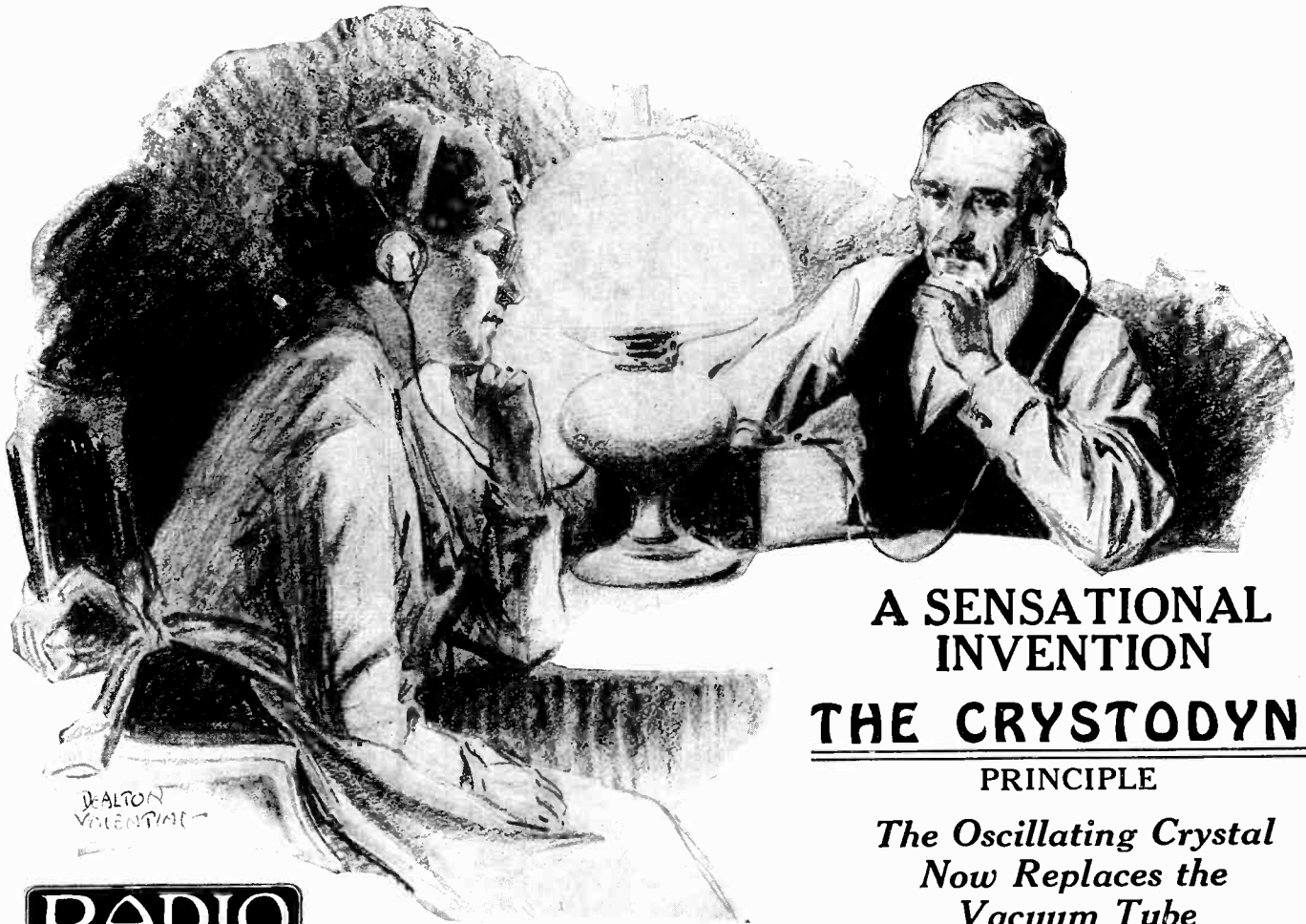

DEALTON  
VOLLENRIE

**A SENSATIONAL  
INVENTION  
THE CRYSTODYNE**

PRINCIPLE

*The Oscillating Crystal  
Now Replaces the  
Vacuum Tube*

SEE

**SEPTEMBER—RADIO NEWS**

**T**HOUSANDS of experimenters, amateur and professional, are daily working on the development of Radio. Every day some new advance is recorded and with it comes new opportunities for further research. No field offers as splendid an opportunity for the amateur designer or experimenter.

RADIO NEWS is the recording agent for the scientific and practical Radio World. Every month in its pages are printed the new developments, the latest successes of the Radio Engineers and all the news of the Industry. Every man interested in the Radio Industry from the scientific, the practical or the amateur viewpoint, reads the pages of RADIO NEWS.

You can have RADIO NEWS delivered to your door for twelve months by filling out the coupon below and enclosing \$2.50. RADIO NEWS is sold on all newsstands for 25c the copy.

*Published by*

**Experimenter Publishing Co., Inc.**  
53 Park Place, New York City

**RADIO  
NEWS**

“RADIO’S GREATEST  
MAGAZINE.”

**The  
Solodyne  
Principle  
Eliminates  
the “B”  
Battery**

These and many  
other articles are  
are featured in  
the September  
issue of  
RADIO NEWS

S.I.-9

EXPERIMENTER PUBLISHING CO., INC.,  
53 Park Place,  
New York City, N. Y.

Enclosed find \$2.50 for my subscription to RADIO NEWS for one year.

Name .....

Address .....

City, State .....

# Build a "PORTABLE" Receiver Too

The high cost of the portable radio receiver can be easily overcome by the "CONSRAD" method of "Building your own receiver" through the use of the "CONSRAD" Pattern No. 12. This pattern is one of the latest of the well known line of "CONSRAD" Patterns designed and written by a staff of expert Radio Engineers. It contains one four-page pamphlet of directions written simply so that anyone can understand it. Two ample blueprints size 16x21 in., with a smaller blueprint for the front panel, altogether they make up a complete set of material for the construction of a practical, highly efficient Portable Receiver that is easy to operate, selective and powerful. The instructions and blueprints are contained in a beautiful, two-color printed envelope size 9x12 in.

PATTERN NO. 12—HOW TO BUILD A PORTABLE RECEIVING SET—PRICE 50c PREPAID. SOLD BY ALL RELIABLE RADIO DEALERS. If your dealer cannot supply you, write direct enclosing 50c and we will send you a copy prepaid.



The Consrad Co.  
233 Fulton Street  
New York City

# Consrad

## 150 Shaves from one Safety Razor Blade

Don't throw away blades. This stropper gets as many as 150 smooth shaves from a blade. Automatically reverses blade, sharpens both edges at once. Guaranteed for life.



**\$1.50 KANNER'S  
Dubeledge Stropper**

Models: For Gillette; Durham Duplex; all single edge blades. Order now—pay when you receive stropper.

**AGENTS WANTED**

Samuel Kanner, 73-K 10<sup>1</sup>/<sub>2</sub> Street, Long Island City, N.Y.

# BACTERIOLOGISTS

make big incomes. Federal, Public Health, City, Hospital, Research and Industrial Positions. Easy for anyone to learn at home. NO EXAMINATIONS. University degrees M. B. and Mb.D. conferred. Also courses in Medicine and Surgery, Chiropraxy and Chiropractic. 18th successful year. Be a SCIENTIST. Complete information Free.

NATIONAL UNIVERSITY OF SCIENCES  
2925 Michigan Blvd. Chicago

## Readers Forum

(Continued from page 476)

Guadalupe Peak in Culberson and Hudspeth Counties is 9,500 feet high.  
Baldy Peak and Mt. Livermore in Jeff Davis County are each 8,382 feet high.  
Mt. Emory in Brewster County, 7,835.  
Sawtooth Mountain in Jeff Davis County, 7,748.  
Chinati Peak in Presidio County, 7,730.  
Black Mountain in Jeff Davis County, 7,550.  
Lost Mine Peak in Brewster County, 7,550.  
Eagle Mountain in Hudspeth County, 7,510.  
Blue Mountain in Jeff Davis County, 7,330.  
Cerro Alto in Hudspeth County, 6,767.

All of these peaks are in Texas. There are few people who know that Texas has eleven mountains which are higher than "the highest peak east of the Rockies."  
Sam J. Helm,  
Grand High Priest, Grand Royal Arch,  
Chapter of Texas,  
Corsicana, Texas.  
(Mount Mitchell is 6,711 ft. and is listed as the "highest peak east of the Rockies." We are pleased to give this correction.—Editor.)

### FROM REPORTER NO. 12627

Editor, *Science and Invention*:  
I received your reporter's card one week ago and have made use of it in going aboard one of the United Fruit Steamers at Boston. This ship, the 'La Marea,' is the most modern of the fleet of beautiful boats. While being shown over the ship, I picked up the material for an article.  
John J. Fisher, Reporter No. 12,627.  
Wollaston, Mass.

(In general, people are glad to co-operate with our reporters if they in turn are courteous. We wish to publicly thank the officials of the United Fruit Steamers for their aid.—Editor.)

### A BRICKBAT

Editor, *Science and Invention*:  
I sent you a manuscript describing a tire and file cleaner. It was returned because the matter was too old. I wish to say that this contest is not fair. Just listen to this. In the July number on page 277 you published an article by A. Blumentfeld wherein he tells how to cut glass under water with a pair of scissors. Now I read how to do this in a "What To Do" book published in 1912.  
Also you published on page 277 an article by Ben Zyl telling how to make a paper ladder that would be of no use whatsoever. I also read how to do this in the same book. Also you told how on page 276 to balance an egg by using sand. (Salt.—Ed.) That is so old that my father, who is sixty years old, knew how to do it when a child.  
Milton White,  
Sacramento, Calif.

(There are times when old material does get into the pages of this journal, but is that any reason why we should expect only old material? Some of the old ideas are practical and are not very well known. Consequently they bear repetition. Some have been published within the past few months and, therefore, will not stand repetition. So don't be discouraged if one or two ideas have been returned. The third may be accepted and pay far more than the effort expended in sending it in. Besides looking for new things is good practice. This is your magazine. If it were full of old material you wouldn't look at it. So let us have the kind of material you would like to read.—Editor.)

### IS THE SUN COLD?

Editor, *Science and Invention*:  
Articles have appeared at different times on the subject of the Mystery of the Sun's Heat, some stating that astronomers believe the sun is at least a billion years old, and a solid ball of coal, the size of the sun would be consumed in 5,000 years. So we must look elsewhere for the source of the sun's heat. I submit a few thoughts on this subject.

There are several reasons for believing that the sun is not a burning mass. Combustion means consumption, and for untold millions of years the sun has been the source of light and heat, with no apparent diminution as far back as man has a record. According to the Mosaic account of the creation, light was the first thing created—naturally the sun. Before the earth was, the sun was established, and it has been giving light ever since—how many million of years we know not. Is it reasonable to suppose that the sun has been a burning mass all this time without being consumed, or at least diminished in power?

Secondly, the sun is approximately 92,000,000 miles from us, and the intervening space is supposed to be occupied by a gaseous (?) body called ether, its estimated temperature to be over 100 degrees below zero. We know that the farther we get away from the earth's surface, toward the

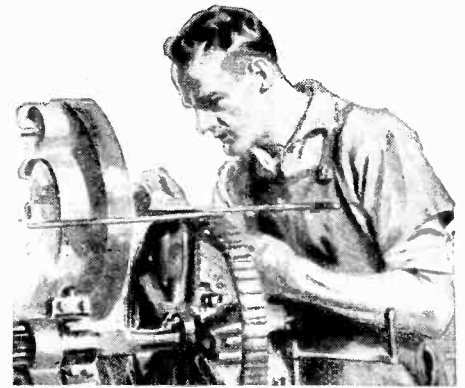

## Expert Toolmakers and Diemakers in Demand

EMPLOYERS everywhere are searching for trained men and are willing to pay them good money.

The manager of one of the largest machine tool works in the world, in a letter requesting us to help him secure the services of technically trained mechanics, wrote—"There is not much difficulty in obtaining average talent—but we must have men of superior ability."

Be one of these trained men. You can do it if you really try. Right at home, in the odds and ends of spare time that now go to waste, the International Correspondence Schools will teach you all you need to know about Toolmaking, Diemaking, Machine Shop Practice or any other subject in which you are interested.

**Mail the Coupon To-day  
for Free Booklet!**

INTERNATIONAL CORRESPONDENCE SCHOOLS  
Box 6164-D, Scranton, Penna.

Without cost or obligation on my part, please tell me how I can qualify for the position or in the subject before which I have marked an X:

#### BUSINESS TRAINING COURSES

- |   |   |
|---|---|
| <input type="checkbox"/> Business Management            | <input type="checkbox"/> Salesmanship           |
| <input type="checkbox"/> Industrial Management          | <input type="checkbox"/> Advertising            |
| <input type="checkbox"/> Personnel Organization         | <input type="checkbox"/> Better Letters         |
| <input type="checkbox"/> Traffic Management             | <input type="checkbox"/> Show Card Lettering    |
| <input type="checkbox"/> Business Law                   | <input type="checkbox"/> Stenography and Typing |
| <input type="checkbox"/> Banking and Banking Law        | <input type="checkbox"/> Business English       |
| <input type="checkbox"/> Accountancy (including C.P.A.) | <input type="checkbox"/> Civil Service          |
| <input type="checkbox"/> Nicholson Cost Accounting      | <input type="checkbox"/> Railway Mail Clerk     |
| <input type="checkbox"/> Bookkeeping                    | <input type="checkbox"/> Common School Subjects |
| <input type="checkbox"/> Private Secretary              | <input type="checkbox"/> High School Subjects   |
| <input type="checkbox"/> Spanish                        | <input type="checkbox"/> French                 |
|   | <input type="checkbox"/> Illustrating           |

#### TECHNICAL AND INDUSTRIAL COURSES

- |   |  |
|---|--|
| <input type="checkbox"/> Electrical Engineering | <input type="checkbox"/> Architect               |
| <input type="checkbox"/> Electric Lighting      | <input type="checkbox"/> Architects' Blue Prints |
| <input type="checkbox"/> Mechanical Engineer    | <input type="checkbox"/> Contractor and Builder  |
| <input type="checkbox"/> Mechanical Draftsman   | <input type="checkbox"/> Architectural Draftsman |
| <input type="checkbox"/> Machine Shop Practice  | <input type="checkbox"/> Concrete Builder        |
| <input type="checkbox"/> Railroad Positions     | <input type="checkbox"/> Structural Engineer     |
| <input type="checkbox"/> Gas Engine Operating   | <input type="checkbox"/> Chemistry               |
| <input type="checkbox"/> Civil Engineer         | <input type="checkbox"/> Pharmacy                |
| <input type="checkbox"/> Surveying and Mapping  | <input type="checkbox"/> Automobile Work         |
| <input type="checkbox"/> Metallurgy             | <input type="checkbox"/> Airplane Engines        |
| <input type="checkbox"/> Steam Engineering      | <input type="checkbox"/> Agriculture and Poultry |
|   | <input type="checkbox"/> Mathematics             |

Name.....  
Street..... 3-6-24  
Address.....  
City..... State.....

Occupation.....  
Persons residing in Canada should send this coupon to the International Correspondence Schools Canadian, Limited, Montreal, Canada

## BLANK CARTRIDGE PISTOL

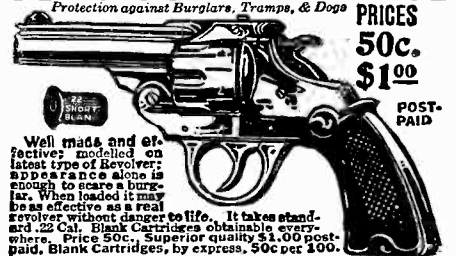

Well made and effective; modeled on latest type of Revolver; appearance alone is enough to scare a burglar. When loaded it may be as effective as a real revolver without danger to life. It takes standard .22 Cal. Blank Cartridges obtainable everywhere. Price 50c. Superior quality \$1.00 post-paid. Blank Cartridges, by express, 50c per 100.

JOHNSON SMITH & CO., Dept. 164 Racine, Wis.

Wonderful, new device, guides your hand; corrects your writing in few days. Big improvement in three hours. No failures. Complete outline FREE. Write C. J. Ozment, Dept. 44 St. Louis, Mo.

# Inventions Wanted!

**YOU** can now learn how to train your mind along scientific inventive lines. No longer need you let your mind wander in unprofitable fields. You can learn how to think of worth-while ideas and make your ideas pay you money. The trouble with most people is that they do not know what to do with their ideas. Millions of dollars go to waste because of these undeveloped ideas. Now for the first time you can learn to harness your thoughts and make them work for you! One little invention, properly developed, may make you independent for life!

**\$112,600**  
in Prizes

The world wants hundreds of new inventions, and will pay big money for them. Even simple inventions—little things like crimped hairpins, the tin bottle-cap, the snap-fastener, the suspenders—have brought fortunes to their inventors. Only recently a magazine published an article which showed that manufacturers had offered \$112,600 in prizes for inventions they want now. You have a glorious opportunity to get one of these prizes—some of them thousands of dollars—if you only learn how to invent.

## You Can Do It At Home

If you have ever had an idea for an invention, or if you would like to become a spare-time or professional inventor, see what this fascinating new course can do for you. Fifteen famous inventors now teach you at home the secrets of invention; show you how to get the information you want, how to perfect your ideas quickly, what to invent, and (just as important) what not to invent. You also learn how to avoid the mistakes which cost many inventors thousands and thousands of dollars. This complete course teaches you everything you want to know—how to get a patent, how to protect your patent rights, how to dispose of your invention to get the greatest possible profits, and hundreds of other facts about invention worth a fortune to you.

### Write For This FREE Book

A wonderful book explaining this fascinating course will be sent to you free. It explains the course in detail, and proves that you can easily train your mind to think inventively so you may become a successful inventor. It shows how this course gives you, in short time, a wealth of information which other inventors learned only after years of hard work and bitter experience. Get the advice of these fifteen famous inventors. Send for this book today. There is no cost or obligation. This bureau is not connected with patent attorneys or manufacturers. Our only work is to teach you how to develop your ideas so they will bring you big money.



**BUREAU OF INVENTIVE SCIENCE**  
Dept. 79  
Wisner Building Rochester, N. Y.

**BUREAU OF INVENTIVE SCIENCE,**  
Dept. 79, Wisner Building, Rochester, N. Y.  
Please send me without cost or obligation your free book "The Science of Invention."

Name .....  
Address .....  
City ..... State .....

sun, the colder it becomes. How can the heat from the sun pass through this extremely cold space without being absorbed? It naturally could not. The heat we experience is evidently generated by the passage of the sun's rays through our atmosphere, and where that atmosphere is most dense (at the earth's surface) the heat is the greatest.

Third, during an eclipse of the sun, when the body of the moon apparently covers its surface, there are seen by the aid of telescopes, scintillations like flames of fire, extending sometimes 100,000 miles from the sun's surface. Is it reasonable to suppose that flames of fire can be extended to such a height?

Fourth, Prof. Sherman, an astronomer of Canada, several years ago discovered the connection between the sun spots and our aurora borealis, or Northern Lights. The latter we know are electrical.

Fifth, the moon receives the light of the sun, but there is no evidence of heat, our satellite having practically no atmosphere.

These facts would seem to prove that no heat comes from the sun, but the heat we experience is the result of the sun's rays passing through our atmosphere.

What, then, is the composition of the sun? No one knows. Some imagine it may be of some substance similar to radium, which has the power to throw off light and heat for a great number of years. But even radium loses its power in time, and its rays are so intense as to burn human flesh.

Did you ever stop to consider that the sun's rays and electricity travel at the same rate of speed—186,000 miles a second? We know there can be no life without electricity, and if the sun's rays are electrical, is it not reasonable to suppose, then, that the sun is an electrical body? Does not this assumption solve many of the questions under consideration?

E. H. Betts,  
Port Angeles, Wash.

(Mr. H. Gernsback has taken up the subject which you have mentioned several times in his Editorials in SCIENCE AND INVENTION Magazine. In one particular Editorial on SCIENTIFIC PARADOXES found in the April, 1921, issue of SCIENCE AND INVENTION Magazine, the following interesting thoughts appear.

"We actually know that all heavenly bodies gravitate in a perfect vacuum. Thus we know that if we were to rise only 500 miles above the surface of the earth, we would find ourselves in an absolute vacuum. We furthermore know that out in space the temperature in this vacuum is—459.4 degrees F., i. e., absolute zero. We can demonstrate by experiment that heat cannot be propagated in a vacuum by conduction or by convection. An ordinary thermos bottle readily proves this. Fill the latter with boiling water, and the outside will stay cold, due to the vacuum separating the inside and the outside of the bottle.

"The case of the sun and the earth is analogous. Heat proper cannot flow between these bodies immersed in a perfect vacuum and besides separated some 92 million miles. So we see that we do not and cannot receive radiant heat rays from the sun.

"Paradoxically enough we know for sure that we get heat somehow in spite of our logic. How? Scientists have a vague notion about it, but they are not too sure. They now think that when the ether waves, devoid of all temperature coming from the sun at a speed of 186,000 miles a second strike our dense atmosphere, the terrific impact results in heat; it is analogous to a meteor, which at a temperature of absolute zero, striking our atmosphere, goes up in metal vapor, due to the enormous friction set up. So we see that after all we do not get heat from the sun at all, merely ether waves, which by shock or impact are turned into heat."—Editor.)

### RAILROAD GATES

Editor, *Science and Invention*:

I notice for some time there have been appearing in your excellent Patent Advice Department, articles regarding safety crossing gates for the railroads. Your Mr. Kraus always advises against patenting such systems.

I wish to give my opinion on such matters. In the first place these gates cost too much and life is cheap to the railroads. The small number of people killed in such accidents does not cost the railroads as much as the cheapest gate installed at every crossing in the country. The roads would rather pay, say twenty-five thousand a year for damages than to pay five or six hundred thousand to install gates. I wish to call to your mind that accident at Porton, Indiana, when the New York Central flyer crashed into the Canadian train. Well I got to work and made a model of my idea to prevent such accidents. It was impossible for one train to hit another even if both engineers were asleep, and do you think they would install it even if I gave it to them? No, life is cheap and it would cost them five hundred dollars to install this at each crossing and two hundred for the attachment on the engine. It is not a question of life with the roads; it is a question of money. The Almighty God of Gold. That is the reason why accidents can come and go, and no attention is paid to them unless they lose someone belonging to themselves.

P. R. George,  
Chicago, Ill.

# The Original Authentic Five Tube Cockaday

Once a Cockaday fan, always a Cockaday fan. The reason is because the Cockaday has a certain clarity and ease of operation that makes a hit with every owner. Here's the new Cockaday, the latest model. The improved 5 tube model with the new system of push-pull amplification that puts this Receiver in a class apart from many receivers of its size and type.

### BUILD IT YOURSELF

With the New "CONSRAC" Pattern No. 11. A complete instruction pattern on the Original, Authentic Improved Cockaday. Pattern contains simple but complete instructions on a four-page pamphlet with large size 18x21 in. blueprint, enclosed in a handsome two-color 9x12 in. folder.

PATTERN NO. 11—Price 50c PREPAID. SOLD BY ALL RELIABLE RADIO DEALERS. If your dealer cannot supply you write direct enclosing 50c and we will mail you the pattern by return mail.



The Consrad Co.  
233 Fulton Street  
New York City

# Consrad

### Agents Wanted! Salesmen—Distributors

to use and introduce attachment that makes Fords run on 94% air. THERMOSTAT on exhaust automatically turns down needle valve as engine warms, exactly as Ford Manual says do by hand.

### Blanche Auto Thermo

An Automatic Carburetor Control Makes Fords start easier winter or summer—saves half gas and oil—cuts repair bills one-half—reduces carbon formation one-half. Sells on sight to every Ford owner as easily as giving him a \$100 bill, because it saves \$100 every 10,000 miles. Cadillac now uses as standard equipment thermostatic carburetor control under Blanche license. You can make Big Money selling this wonderful proven device. Experience not necessary. Blanche plan will start you without capital in a business of your own that makes you from \$250 to \$2,000 a month profit. Write for free circulars Now!

A. C. Blanche & Co. Dept. 421 Chicago 602 W. Lake Street

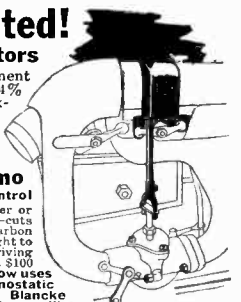

# PIMPLES

Your Skin Can Be Quickly Cleared of Pimples, Blackheads, Acne Eruptions on the face or body, Barbers Itch, Eczema, Enlarged Pores and Oily or Shiny Skin. Write today for my FREE BOOKLET, "A CLEAR-TONE SKIN,"—telling how I cured myself after being afflicted 15 years. E. S. GIVENS, 168 Chemical Bldg., Kansas City, Mo.

C. G. CONN, Ltd., Elkhart, Ind.  
 956 Conn Bldg., Elkhart, Ind.  
 Please send "Success in Music" and details of trial offer on \_\_\_\_\_ instrument

Name \_\_\_\_\_  
 St. or R. F. D. \_\_\_\_\_  
 City, State \_\_\_\_\_  
 County \_\_\_\_\_

## Mail for FREE BOOK

Sousa and other world-famous artists who use and endorse Conn instruments as—  
 —Supreme in tone  
 —Perfect in scale  
 —Most reliable in action  
 —Easiest to play

will help you choose the Conn which suits your talent, in the pages of this book. Free Trial! Easy Payments. Send coupon for details.

C. G. CONN, Ltd., Elkhart, Ind.



**CONN**  
 BAND INSTRUMENTS  
 WORLD LARGEST MANUFACTURERS

### Standard of Spanish Army Genuine Astra

**\$7.75**

Adopted by French During World War



The finest European Pistol—Drop Forged Blue Steel Throughout—uses standard ammunition, an accurate, hard-hitting, brand-new weapon.

Bought before recent tariff raise. Buy now from sole U. S. importers and save about 1/2 on these fine guns.

**\$7.75** 25 cal., 7 shot ASTRA, C.O. Automatic.  
 8.95 25 Cal., 7 shot ASTRA, Automatic  
 9.95 25 cal., 7 shot ASTRA, triple safety.  
 10.95 32 cal., 10 shot ASTRA, extra magazine.

**\$16.95 "The Plainsman" Revolver**



32-20 and 38 long calibers, except for difference in calibre, the same gun in weight, size and appearance. A regular he-man, best blued steel, fully guaranteed, uses standard revolver ammunition. Only \$16.95.

Write for firearms catalogue. We guarantee perfect workmanship and material; every gun brand new; of drop forged steel throughout. Before buying any gun insist on this guarantee. Send no money unless you wish. Pay postman on delivery plus postage. Money cheerfully refunded if not fully satisfied. **ACT NOW to get these SPECIAL LOW PRICES. WRITE TODAY.**

**CALIFORNIA TRADING COMPANY**  
 Dept. 25-9 747 Warehouse St., Los Angeles, Cal.

### A PERFECT NOSE



shaped at home while you sleep. Rapid, painless and safe. The ANITA is the genuine, unique and most comfortable NOSE ADJUSTER absolutely guaranteed. Highly recommended by Physicians. Winner Gold Medal Paris, 1923. Write for FREE booklet, "The ANITA CO.", Dept. 973, Anita Bldg., Newark, N.J.

You can be quickly cured, if you

## STAMMER

Send 10 cents for 284-page book on Stammering and Stuttering, "Its Cause and Cure." It tells how I cured myself after stammering 20 yrs. B. N. Bogue, 8108 Bogue Bldg., 1147 N. III. St., Indianapolis

### ADULTS! SEX KNOWLEDGE BOOKS

Instructive, authoritative, profusely illustrated in natural colors, etc. The worth-while sort. Contains everything one should know both before and after marriage to enjoy health and happiness. Large Catalog, 10c. F. SMETANA & CO. Saginaw, West Side, Mich.

(It is a known fact that the railroads in the United States spend a great deal of money for maintenance, repairs and improvements. The difficulty is that a great many inventors believe that their ideas are practical, when as a matter of fact the systems are entirely unsuited and could never be applied. A device to be approved must work in all kinds of weather, under all conditions, and on all types of track. This includes the sharp curves, the steep grades, long tunnels, narrow bridges, etc. We are quite sure that if you had built a working model of your system, and had demonstrated it to the proper railway concerns and showed them where the system meant a saving in life, as well as in actual money, the officials of the concern would have listened to your plea.—Editor.)

### ELECTRICITY FROM THE SUN

Editor, Science and Invention:

On page 846 of the January, 1922, issue of SCIENCE AND INVENTION, in question No. 1172, you mention having knowledge of five inventors, who claim to derive electricity from the air or by the action of the sun upon certain chemicals. I wish you to give me the names of the inventors and what data you can on the subject, for I am very much interested in locating a certain man, engaged in this work. They say truth is stranger than fiction; and it is, in this case—but the following are absolute facts, that can be vouched for by myself, my father, the superintendent of our lumber camp, and some of the resident mountaineers.

On the morning of July 16th, 1918, three of us left Blairs Mills, Huntingdon County, Penna., to cross the Kineamajig Mt. to New Germantown, Perry County, Penna. We saw a fine tract of timber in the Dead Horse Valley, between the Tuscarora and Kineamajig, and left the car along a back road and tramped up through the valley a mile or more and then started for the summit of the Kineamajig. It was a broiling hot day, and about noon we entered a little clearing, where was built a substantial log cabin with a flat top. Interested in finding such a well-kept place in this section, and wishing to learn all possible about the timber, we struck up a conversation with the elderly man—by his conversation one could tell he was not a native of the mountains. But he proved a veritable encyclopedia for information relative to the surrounding country. We never question mountaineers about their business, so went on in search of various timbers. Driven by an approaching thunderstorm, we hurried back to the shack for shelter—the old man was busy on the roof of the cottage covering something, but gestured for us to enter inside—which we did, and were amazed to find ourselves in a perfectly appointed, ELECTRICALLY LIGHTED library. As we knew there were no large streams near, and we had noticed no wires outside, we were surprised, and naturally asked the man the circumstances, when he finally came down from the roof. Then he explained that for years he had been working on the problem of making the sun produce electricity, and had almost solved the problem to make it commercially possible. After the storm had passed over he took us to the roof of the cabin, and showed us "the production cells," as he called the large number of these jars. He claimed that by exposure of these cells to the sun for two days he could generate and store up sufficient electricity to light his cabin for one week, continuous lighting. Of course, this all seemed like a fake idea, but there was the proof. We had to hurry along back to our car in order to get back to our camp by night, so we asked the man for his name and address in case we could ever use his idea or aid him. He gave his name, but no address, and said we could always find him at the cabin. He did ask us not to mention this to anyone and we, the three of us, never have, until now. I am writing to you. We did go back there again in the spring of 1919, but all we found was a tumbled-down log cabin, falling to pieces, and some mountaineers had told our superintendent of a big truck going up the valley early in the preceding Fall and returning the following day with a big load, all covered with tarpaulins.

I hope you can give me the names and addresses of the inventors who claim they can produce electricity by this means, and I shall try to find out if any of them are the one I am seeking.

Of course there is considerable I have not told; should I not find the name among the list you send me, I should be glad to write you an article and giving the data as I remember it. It would serve as feature material for your magazine.

As a clue to your search; several years ago, before a meeting of an Engineering Society in New York City, on the same program with Dr. Geo. Spratt, the man who is the possessor of all the papers of the late Octave Chanute, there was a lecturer who spoke on this subject—of making the sun produce electricity. This was about two years ago.

R. C. Templin,  
 Coatesville, Pa.

(Has any one of our readers heard of this particular method of obtaining electricity from the sun? We will appreciate hearing from you on this point. There are several experiments which have been made along this particular line in a smaller way, but none to the extent mentioned in the above letter.—Editor.)

## 2 1/2 Tons Heats 5 Rooms!

"There is no heater to compare with the Bulldog. I burned 2 1/2 tons of coal last winter and heated five rooms and bath."  
 —Walter Geary, Gloucester, Mass.

That's what the Bulldog does with coal! Here's what it does with about the lowest grade fuel you can think of!

"I can run my Bulldog furnace steady for fourteen days in normal weather conditions on the actual cost of fifty cents." So writes F. R. Redetzke, of Cleveland, North Dakota, and he adds: "Hard to believe, is it? That's what some of my neighbors thought until I showed them! We have an unlimited amount of grain screenings in this country. That's the fuel I am using."

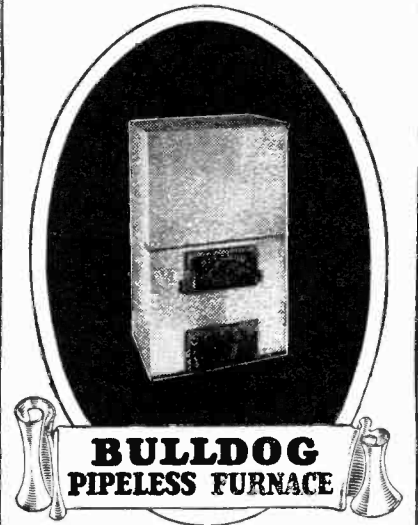

**BULLDOG PIPELESS FURNACE**

Comes Completely Erected!  
 Fits Any Height of Basement  
 Goes Through Any Door  
 You Install It Yourself!

If you are even thinking of a pipeless furnace, or any furnace, write for our free catalog. The Bulldog is one furnace you MUST investigate. Comes completely erected, fits any height of basement, goes through any door, and you install it yourself! A really extraordinary development in heating.

## No Money Down!

The Bulldog is sent you for free inspection. Then, if satisfied, you make only small monthly payments, at our amazingly low price! Factory connections in both East and West. We ship from nearest point. Don't consider buying any furnace until you find out about the Bulldog. Write at once for our special offer and our free catalog, together with the wonderful record of Bulldog success. Get ready for winter NOW! Mail this coupon TODAY!

**Babson Bros.**  
 19th & California Ave., Dept. 14-26 Chicago

Without obligating me in any way please send me your free catalog and special offer on the Bulldog Pipeless Furnace.  
 Print name and address plainly.

Name \_\_\_\_\_  
 Address \_\_\_\_\_

Insure your copy reaching you each month. Subscribe to Science and Invention—\$2.50 a year. Experimenter Publishing Co., 53 Park Place, N. Y. C.

# Opportunity Ad-lets

**YOU** will find many remarkable opportunities and real bargains in these columns. It will pay you to read and investigate the offerings made every month by reliable firms, dealers and amateurs from all over the country. No matter what you may be seeking, whether supplies, automobile accessories, the opportunity to make money, or anything else, you will find listed here the best and most attractive specials of the month.

Advertisements in this section twelve cents a word for each insertion. Name and address must be included at the above rate. Cash should accompany all classified advertisements unless placed by an accredited advertising agency. No advertisement for less than 10 words accepted. Ten per cent. discount for 6 issues, 20 per cent. discount for 12 issues. Objectionable or misleading advertisements not accepted. Advertisements for the November issue must reach us not later than September 15th.

## The Circulation of Science and Invention is over 150,000 and climbing every month

EXPERIMENTER PUBLISHING CO., INC., 53 Park Place, New York City, N. Y.

### Agents Wanted

**Salesmen: Sell tailoring.** It's a great staple that sells the year around. You don't have to look for prospects; every man is a possible customer, and with a good line at the right price you sell him again and again. Our line is a good line. It offers an assortment of almost 150 Virgin Wool fabrics of the finest quality, made up in suit or overcoat to special order, for only \$31.75. This price is \$25 lower than store prices. It is this that enables our men to make the big money they do. Earnings of from \$75 to \$125 a week are common with our men and in season many of them make even more. Our selling outfit is a winner; the fabric assortment is powerful and impressive and the advertising helps contained are tremendously effective. Write at once for the full facts about what we believe to be the greatest selling opportunity in the field today. When you write, tell us about yourself. It will help us to give you action. But write at once. Now's the time to get started. Address Dept. 215, Goodwear, Chicago, Inc., 814 West Adams St., Chicago.

**Agents—Best seller; Jem Rubber Repair for tires and tubes; supersedes vulcanization at a saving of over 800 per cent; put it on cold. It vulcanizes itself in two minutes and is guaranteed to last the life of the tire or tube; sells to every auto owner and accessory dealer. For particulars how to make big money and free sample, address Amazon Rubber Co., Dept. 601, Philadelphia, Pa.**

**Big money and fast sales.** Every owner buys gold initials for his auto. You charge \$1.50; make \$1.35. Ten orders daily easy. Write for particulars and free samples. American Monogram Co. Dept. 17, East Orange, N. J.

**We start you without a dollar.** Soaps, Extracts, Perfumes, Toilet Goods. Experience unnecessary. Carnation Co., Dept. 232, St. Louis.

**Make \$25 to \$50 week representing Clows' Famous Philadelphia Hosiery,** direct from mill—for men, women, children. Every pair guaranteed. Prices that win. Free book "How to Start" tells the story. George Clows Company, Desk 27, Philadelphia, Pa.

**Only one sale a day means \$200 per month.** Five sales, \$1,000 per month. Mergakon new adding machine. Retail \$15. Work equals \$350 machine. Adds, subtracts, multiples, divides automatically. Speedy, accurate, durable, handsome. Five-year guarantee. Offices, stores, factories, garages buy one to dozen. A fortune for live agents. Write quick for protected territory and free trial offer. Lightning Calculator Co., Dept. W., Grand Rapids, Mich.

**Earn big money fast applying gold initials to autos.** Every owner buys—\$1.35 profit on \$1.50 sale—particulars and samples free. Write quick. Lithogram Co., Dept. 19, East Orange, N. J.

**Write and learn how to start profitable business without capital or experience.** Silvering mirrors, refinishing auto headlights, tableware plating. Outfit furnished. International Laboratories, Dept. 25, 809 Fifth Ave., New York.

**We want Salesmen and Agents,** either whole or side line, to sell our low priced radio books to the trade. Excellent proposition for live wires. The E. I. Company, Publishers, 333 Fulton Street, New York City.

**Earn \$10 daily silvering mirrors, plating and refinishing metalware, chandeliers, bedsteads, headlights.** Outfit furnished. N. Decte Laboratories, 1133 Broadway, New York.

**\$60—\$200 a week.** Genuine Gold Letters for store windows. Easily applied. Free samples. Liberal offer to general agents. Metallic Letter Co., 411 B., North Clark, Chicago.

**Agents—Big returns, fast office seller; particulars and samples free.** One Dip Pen Co., 12 Daily Record Bldg., Baltimore, Md.

**Make \$120 Weekly in Spare Time—Sell what the public wants—long distance radio receiving sets.** Two sales weekly pays \$120 profit. No big investment, no canvassing. Sharpe of Colorado made \$955 in one month. Representatives wanted at once. This plan is sweeping the country—write today giving name of your county. Ozarka, 825 Washington Blvd., Chicago.

**Big money and fast sales.** Every owner buys gold initials for his auto. You charge \$1.50, make \$1.44. 10 orders daily easy. Samples and information free. World Monogram Co., Dept. 32, Newark, N. J.

**Rummage sales make \$50.00 daily.** Offer wonderful value. We start you. "Wholesale Distributors." Dept. 32, 609 Division Street, Chicago.

**Best proposition in the Specialty Field.** Perry Lykoll Paintings, Photo Medallions, and Novelties have no equal. Every interview means a sale. 600% profit. Write for details. Perry Photo Novelty Corporation, Sect. 817, 360 Bowers, New York.

**Agents, both sexes, we manufacture and control new household article.** Fast seller. Big profits. Exclusive territory. Write now. Connolly, 123 Liberty St., New York.

**Men's Shirts.** Easy to sell. Big demand everywhere. Make \$15.00 daily. Undersell stores. Complete lines. Exclusive patterns. Free samples. Chicago Shirt Manufacturers, 229 W. Van Buren, Factory 212, Chicago.

**Agents: Make \$5.00—\$25.00 daily—all or spare time selling new sensational novelty wanted every home.** Wonderful gift. Pay advanced. We deliver and collect. Art Craft Home Products Co., 357B West 63rd, Chicago.

**Agents—90c an hour to advertise and distribute samples to consumer.** Write quick for territory and particulars. American Products Co., 1834, American Building, Cincinnati, O.

**Big Money selling New Household cleaner.** Washes and dries windows, Sweeps, scrubs, mops. Complete outfit less than brooms. Over 100 per cent profit. Harper Brush Works, 152—2nd St., Fairfield, Iowa.

### Agents Wanted (Continued)

**Tailoring Agents! \$90 week and steady job taking orders** for Longworth All-wool suits and overcoats \$23.75. Boys' suits \$11.75. Special offer \$15 cash and free suit for 3 days' spare-time work. Postal brings big outfit free—no waiting, no deposit. John G. Longworth & Sons, Dept. 50V, Address—1301-11 West Congress St., Chicago.

**Agents—Write for Free Samples.** Sell Madison "Better-Made" Shirts for large Manufacturer direct to wearer. No capital or experience required. Many earn \$100 weekly and bonus. Madison Mills, 561 Broadway, New York.

**Radiolite system of battery charging fastest, best method.** Real chance to own paying business. Saves batteries and money for auto owners. Write for free demonstration offer. Radiolite Co., St. Paul, Minn.

**Agents—Make \$25.00—\$100.00 weekly selling Comet Sprayers and Autowashers to farmers and Autoists.** All brass. Throws continuous stream. Established 30 years. Particulars free. Rusler Co., Johnstown, Ohio, Box C17.

**Agents Coining Money! \$1.40 profit on every \$1.50 sale.** Monogramming Automobiles. Free Samples. Worcester Monogram Co., Worcester, Mass.

**Succeed With Your Own Products—Formulas, Processes.** Different, Dependable, Profitable. Catalog Free. D. Thaxly Co., Washington, D. C.

**Agents—Pick up \$5.40 for few minutes work.** Then, if you like, become "regular" representative making \$10-\$15 daily. Write quick for particulars. Pitkin Company, 694 Pitkin Building, Newark, New York.

**Agents—Write for Free samples 35 Hosiery and Neckwear as high as 120 percent commission.** Free Ties and Hosiery to Customers. The Lexington Co., Dept. 1410, Lexington, Kentucky.

### American Made Toys

**Opportunity to start Manufacturing Metal Toys and Novelties.** No experience necessary. Enormous demand exceeds supply. We furnish, at cost, casting forms for production and buy entire output, also place yearly contract orders. Casting forms made to order. Catalog, advice and information free. Metal Cast Products Co., 1695 Boston Road, New York.

### Battle Photos and War Relics

**For Dens: Relics Collected from Europe's Battlefields.** Firearms, medals, helmets, etc. Illustrated catalogue and sample War photographs 25c. Lieut. Welsh, 2117 Regent Place, Brooklyn, N. Y.

### Books

**Perpetual Motion, by Percy Verance.** A history of the efforts to discover same from earliest days to the present together with a scientific discussion regarding the possibility of its ultimate achievement. Profusely illustrated. 357 pages. Price postpaid, \$2.00. The Enlightenment Specialty Co., 305 Fourth St., Edwardsville, Ill.

**"Nature's Finer Forces," Vibrations; Lights; Color tones; Electromagnets; Odicuras; Radio; Coldlights; Inventions; Wonderful Opportunities; Fifty Lessons; Marvelous Cures; Illustrated 270 pages. \$2.00. Deluxe \$3.00. Stevens Research Laboratories, 242 Powell, San Francisco.**

**Hypnotism—Astounding controls. Wants gratified. Disease eliminated. 25 Easy Lessons \$1.00 "Mindreading" (Any distance) wonderful. Success guaranteed. 60c "How to Win in Business, Love and Society" 400 pages \$3.00. Catalog free. Science Institute, SE 1014 Belmont, Chicago.**

**Free—Upon request will send you my literature illustrating the following books.** Astrology, Character, Clairvoyance, Concentration, Healing, Hypnotism, Magnetism, Mediumship, Personal Magnetism, Personality, Physiology, Salesmanship, Seership, Success, Sex, Will, Your Philosophy, Gazing Crystals, etc. A. W. Martens, E. E. 6, Burlington, Iowa.

### Business Opportunities

**If you have adaptability to selling specialties, exclusive territory is available on the Hush-A-Phone.** This device is generally recognized by the largest concerns in the country as superior to a phone booth for voice privacy, office quiet, and telephoning in noisy places. Over a thousand banks have adopted it. It is without competition. Energetic men can make a life occupation of selling the Hush-A-Phone in their section. Office appliance, and telephone men particularly adapted. Write for proposition. Hush-A-Phone Corp., Room 1311, 19 Madison Avenue, New York City.

**Dollars yearly in your backyard.** No mushroom dope. Particulars free. Metz, 313 East 89th, New York.

**You can have a business-profession of your own and earn big income in service fees.** A new system of foot correction; readily learned by anyone at home in a few weeks. Easy terms for training, openings everywhere with all the trade you can attend to. No capital required or goods to buy, no agency or soliciting. Address Stephenson Laboratory, 18 Back Bay, Boston, Mass.

**\$10 daily silvering mirrors, plating and refinishing lamps, reflectors, autos, beds, chandeliers by new method.** Outfit furnished. Write Gunmetal Co., Ave. D, Decatur, Ill.

### Business Opportunities (Continued)

**Learn Automobile Painting: Big money; own boss.** Success Guaranteed. Particulars free. D. H. Miller, Avoca, N. Y.

**Establish Yourself—at Home—As a Photographic Expert.** Make \$75 a week while learning. Write at once for Temporary offer. International Studios, Dept. 14-26, 3601 Michigan Ave., Chicago.

**\$10 daily silvering mirrors, plating and refinishing lamps, reflectors, autos, beds, chandeliers by new method.** Outfit furnished. Write Gunmetal Co., Ave. D, Decatur, Ill.

**Stop Plodding! Be Successful. Operate a Tire Repair Shop.** Make big profits in your locality. We teach you and furnish complete equipments \$100 up. Book of Opportunity free. Haywood's, 1312 South Oakley Avenue, Chicago.

**Free Advice. How to be Successful in Real Estate, particulars.** Macdonald Cooperative Realty, San Diego.

**I Made \$100,000 as Real Estate Specialist.** Free information tell how. American Business Builders, Dept. A-359, 1133 Broadway, New York.

**Patent applications filed guarding priority \$20; drawings deferred \$15; caveat advantages; basic protection. Inventors' Service, 11 Broadway, N. Y.**

### Chemistry

**Learn Chemistry at Home.** Dr. T. O'Connor Sloane noted educator and scientific authority, will teach you. Our home study correspondence course fits you to take a position as chemist. See our ad on page 595 of this issue. Chemical Institute of New York, 66 W. Broadway, New York City.

### Correspondence Courses

**Used correspondence courses of all schools sold, rented and exchanged.** New 1924 catalogue free. (Courses bought). Lee Mountain, Pisgah, Alabama.

**Used correspondence courses bought and sold.** Bargain catalogue 1,000 courses free. Students' Exchange, Dept. 4, 47 West 42nd St., New York.

### Films Developed

**Amazing Trial Offer! Your Kodak Films developed; 6 fine glossy prints; only 15c.** Associated Photo, Box 1463-P, Cincinnati, Ohio.

### For Advertisers

**24 words—355 Rural Weeklies \$14.20.** Ad-Meyer, 4112 St. Hartford, St. Louis, Mo.

**Advertising in all magazines and newspapers at publisher's lowest rates.** Sales letters, booklets, folders, planned written, illustrated. Taylor's Advertising Service, Dept. Y, Freeport, Illinois.

### For Inventors

**We Develop Your Ideas into commercial shape for presentation to purchasers making working models, drawings, experiments or tests.** Courtesy, efficiency, secrecy and ample equipment; 30 years' experience. Duconor-Rich Engineering Co., 504 Pacific Mutual Bldg., Los Angeles, Cal.

**Unpatented Ideas Can Be Sold.** I tell you how and help you make the sale. Free particulars (Copyrighted). Write W. T. Greene, 808 Jenifer Bldg., Washington, D. C.

**Classified Advertising will sell your patent.** Write for rates leading newspapers and magazines. Taylor's Advertising Service, Dept. T, Freeport, Illinois.

**Your Chemical problems solved and working process furnished for Five Dollars.** Write inc. W. Sredman Richards, Consulting Chemist, Box 2402, Boston, Mass.

**Cashing In—If you have a practical, useful invention to sell (patented or pending), write us promptly.** American Patents Corporation, Barrister Building, Washington, D.C.

### Formulas

**Money-making Books, Plans, Formulas.** Catalogue Free. Ideal Book Shop, 5501-E, North Robey, Chicago.

### For the Photographer

**Have you a Camera? Write for free sample of our big magazine, showing how to make better pictures and earn money.** American Photography, 118 Camera House, Boston, 17, Mass.

### For Sale

**For Sale or Trade.** Concrete Culvert. Particulars on request. Smith Caldwell, Castague, Mont.



**For Sale (Continued)**

For Sale—Patent on alarm clock. Variable sound. Jack Moore, 131 Circle Drive, Wichita, Kansas.

**Games and Entertainment**

Tricks, Puzzles, Jokes, Magical Apparatus, Plays, Stage Supplies, Mind-Reading Acts and Sensational Escapes. Send 10c for 160-page illustrated 1922 professional catalogue. Oaks Magical Co., Dept. 549, Oshkosh, Wis.

**Health**

Free to men—Information of a scientific nature that has brought physical vigor and happiness to thousands. No charge; no obligation. Enclose stamp for reply. C. I. Wood & Co., Colorado Springs, Colorado.

Booklets on healing. Particulars for stamp. Arthur Stevens, Vauseon, O.

Free—Stop using tobacco. We will give free information how to conquer habit easily and permanently. Results guaranteed. Anti-Tobacco League Box M, Omaha, Neb.

**Help Wanted**

We want Salesmen and Agents, either whole or side line to sell our low priced radio books to the trade. Excellent proposition for live wires. The E. I. Company, Publishers, 233 Fulton Street, New York City.

Detectives Needed Everywhere. Work home or travel. Experience unnecessary. Write, George Wagner, former Government Detective, 1968 Broadway, N. Y.

Silvering Mirrors, French plate. Easily learned. Immense profits. Plans free. Wear Mirror Works, Excelsior Springs, Mo.

Earn \$25 Weekly, spare time, writing for newspapers, magazines. Experience unnecessary; details free. Press Syndicate, 986 St. Louis, Mo.

All men, women, boys, girls, 17 to 65, willing to accept Government positions, \$117-\$250, traveling or stationary, write Mr. Ozmont, 293 St. Louis, Mo., immediately.

Detectives Earn Big Money. Travel. Excellent opportunity. Great demand everywhere. Experience unnecessary. Particulars free. Write, American Detective System, 1974 Broadway, N. Y.

Railway Postal Clerks—Start \$133 month. Railroad pass; expenses paid; questions free. Columbus Institute, H-4, Columbus, Ohio.

Earn \$1.20 an hour cutting blanks at home; anywhere; spare time. Men only. Send addressed reply envelope. Goodyear Sy., 147 W. 23d St., New York.

Get U. S. Government Life Jobs. Men-women-18 up. \$95 to \$250 month. Steady work. Paid vacation. Short hours. Common education usually sufficient. Pull unnecessary. List positions obtainable and specimen examination questions—free. Write immediately. Franklin Institute, Dept. N23, Rochester, N. Y.

**Instruction**

Learn Chemistry at Home. Dr. T. O'Connor Sloane, noted educator and scientific authority, will teach you. Our home study correspondence course fits you to take a position as chemist. See our ad on page 507 of this issue. Chemical Institute of New York, 66 W. Broadway, New York City.

Learn Ventri-louism. Book of Instruction, 30c. J. Tillberg, Proctor, Vermont.

Correspondence Courses sold complete: one-third usual prices because slightly used; easy terms; money back guarantee. All schools and subjects. Write for special Free catalog. Courses bought for cash. Economy Educator Service, H202, West 49th St., New York.

**Machinery and Tools**

Concrete Building Block Machines and Molds. Catalogue free. Concrete Machine Co., 305 South Third St., St. Louis, Mo.

Perfect Working Models, Instruments mechanical or Electric, Automatic special Machinery, Tools, Dies, built by capable Master Mechanic. Otto Berner, 453 East 160 St., New York.

**Manufacturing**

To order: Metal articles, simple, or complicated machinery. Models, tools, patterns. Experimenting. Parma Engineering Works, Brooklyn Station, Cleveland, Ohio.

Let Me Write your sales letters, booklets, folders. Long experience, fair prices, quick service. L. Taylor, Box 44X, Freeport, Illinois.

**Miscellaneous**

Hindu Psychology, Yogi, Personal Magnetism. The Secret Sciences, Books and Courses. Large Illustrated Private Catalogue, with "How Realize Any Desire," 25c. Adaras, 116 South Michigan, Chicago.

Camera—Hospital: Expert Repairing a specialty; Send your broken camera. Turner, 1679 Avenue A, New York.

Consulting engineer in mechanical design and development. Clifford H. McClain, 1300 Darby Road, Brookline, Penna.

Where to Buy 250,000 Articles at wholesale prices. 50c, 500 Gummed Labels, 20 words, 35c. Peter DeKort, 355 Clay Street, Paterson, New Jersey.

**Models and Model Supplies**

Models, Dies, Metal Stampings, Light Manufacturing, Modern Shop. Reasonable Prices. Osborne Register Company, Pearl at Elm, Cincinnati.

**Motorcycles—Bicycles**

Don't buy a Bicycle Motor Attachment until you get our catalogue and prices. Shaw Mfg. Co., Dept. 6, Galesburg, Kansas.

**Patent Attorneys**

Patents. Send for free booklet. Highest references. Best results. Promptness assured. Send model or drawing for examination and opinion. Watson E. Coleman, Patent Attorney, 614 G Street, N. W., Washington, D. C.

Get your own patents. Application blanks, complete instructions \$1. Cutting Bros., Campbell, Calif.

Inventors write me about patents. My fees payable monthly. Booklet free. Frank Fuller, Washington, D. C.

Unpatented Ideas Can Be Sold. I tell you how and help you make the sale. Free particulars (Copyrighted 1923). Write W. T. Greene, 809 Jenifer Bldg., Washington, D. C.

"Inventor's Advisor," the valuable Patentbook with 139 Mechanical movements and illustrations, sent free upon request. M. I. Labiner, Patent Attorney, 3 Park Row, New York.

Lacey Patent-Sense. "The book the inventor keeps." Free. See page 510.

"Inventors' Guide" free on request; gives valuable information and advice for all who have original ideas or improvements. Frank Ledermann, Registered Attorney and Engineer, 15-E Park Row, New York.

Herbert Jenner, Patent Attorney and Mechanical Expert, 824 F Street, Washington, D. C. I report if patent obtainable and exact cost. Send for circular.

M. P. Laughlin, Patents, Engineer-Attorney, 47 West 42nd Street, New York.

Patents—Write for our Guide Books and "Record of Invention Blank" before disclosing inventions. Send model or sketch of your invention for Examination and Instructions. No charge for the above information. See advertisement on page 511. Victor J. Evans & Co., 194 Ninth, Washington, D. C.

Inventors: Send sketch or model for free opinion concerning patentable nature and exact cost of patent. Book "How to Obtain a Patent" sent free. Tells what every inventor should know. Established twenty-eight years. Highest references. Prompt service. Reasonable charges. Chandice & Chandice, 176 Seventh, Washington, D. C.

Patents Procured, Trade-Marks Registered—A comprehensive, experienced, prompt service for the protection and development of your ideas. Preliminary advice gladly furnished without charge. Booklet of information and form for disclosing idea free on request. Richard B. Owen, 130 Owen Bldg., Washington, D. C., or 2278-T Woolworth Bldg., New York.

Patents Procured. Send sketch or model today for examination, prompt report and advice. No charge for preliminary advice. Write for free booklets "How to Obtain a Patent" and "Invention and Industry" and blank form on which to disclose your idea. Highest references. Promptness assured. Clarence A. O'Brien, Registered Patent Lawyer, 926 Security Bank Building, Directly across the street from Patent Office, Washington, D. C.

Monroe Miller, Ouray Bldg., Washington, D. C. Patent Attorney, Mechanical, Electrical Expert, Free Blue Book gives candid advice.

Inventors—Send for form "Evidence of Conception" to be signed and witnessed. Form, fee schedule, information free. Lancaster and Allwine, 242 Ouray Bldg., Washington, D. C.

Millions spent annually for ideas! Hundreds now wanted! Patent yours and profit! Write today for free books—tell how to protect yourself, how to invent, ideas wanted, how we help you sell, etc. American Industries, Inc., 212 Kresge Bldg., Washington, D. C.

The Patentome Impartial advice to Inventors and manufacturers. Mailed on request. Anderson & Son, Patent and Trade Mark Lawyers, Established 1865. 637 F St., Washington, D. C.

**Patents**

M. P. Laughlin, Patents, Engineer-Attorney, 47 West 42nd Street, New York.

Inventions commercialized. Patented or unpatented. Write Adam Fisher Mfg. Co., 278, St. Louis, Mo.

**Patents For Sale**

For Sale—Patent on combination cigarette and book match case—metal—attractive novelty—should prove big seller. Patented May, 1924. L. N. O., P.O. Box 72, Franklin Square, L. I.

**Personal**

Exchange interesting letters with new friends. Write Dolly Gray Club, Box 186K, Denver, Colorado. Stamp appreciated.

Exchange Cheery Letters with new friends. Write Betty Lee, Inc., Box 820, City Hall Station, New York City. Stamp appreciated.

Lonely—Join our club, make friends everywhere. Particulars Free. Write Frances Mathews, Box 26, Oakland, Calif.

**Phonographic Supplies**

Build Your Phonograph. Quality phonographs, Famous Serenado Motors. Also original Perfection Motors. Electric Motors, tonearms, reproducers, amplifiers, case material, accessories. Free blueprints and building instructions. Big saving. Wonderful results. Prompt delivery. Catalogue mailed for ten cents. Hoosier Mfg. & Supply Company, 321 Baldwin Block, Indianapolis, Indiana.

**Photoplays, Stories, Etc.**

Big money writing photoplays, stories, poems, song. Send for free copy America's greatest magazine for writers. Tells you how to write and sell. Writer's Digest, 637 Butler Bldg., Cincinnati, Ohio.

\$ \$ \$ For Ideas. Photoplay Plots Accepted any form: revised, criticized, copyrighted, marketed. Advice free. Universal Scenario Corporation, 223 Security Bldg., Santa Monica & Western, Hollywood, California.

**Radio**

Attention! 50 Vacuum Tube Hook-Ups. The greatest collection of Vacuum Tube Circuits ever brought under two covers at such insignificant cost. These diagrams will be found in the great "Rasco" catalogue which contains raw materials and parts in a greater profusion than any other catalogue. 15c in stamps or coin will bring the catalogue to you. Radio Specialty Company, 100 Park Place, New York City.

Boys, don't overlook this! The "Rasco" Baby Detector. Greatest detector ever brought out with molded base. Fully adjustable. See former advertisements in this publication or our catalogue. Detector with Galena Crystal complete, 50c; the same Detector with Radiocite Crystal, 75c, prepaid. Send for yours today. Radio Specialty Co., 100 Park Place, New York City.

68 Stations on Crystal without tubes or batteries. You fellows who haven't tried my hook-up don't know what you are missing. Write. Leon Lambert, 535 Volusia, Wichita, Kansas.

Wanted: A Telephonaphone: home made or otherwise, will pay good price; send description and if possible, a photograph. Eugene Dwyer, 191 Linden Avenue, Brooklyn, N. Y.

**Salesmen Wanted**

A Salesman wanted in every town or city within 25 miles of a broadcasting station to sell Radiogram, the complete radio receiving set that retails for \$2.50. With Radiogram there is nothing else to buy—the outfit includes the Radiogram receiving apparatus, 1,000-ohm phone, and aerial outfit. The cheapest radio outfit on the market—yet as practical as the most expensive. Big money to the right men. Send \$2.00 for sample outfit. The Radiogram Corp., 68B West Broadway, N. Y. City.

Salesmen Earn \$50.00 weekly selling custom-made shirts at ready-made shirt prices. 100 latest patterns; prices \$2.95 up. Shirts individually cut. Unconditional guarantee. Custom Built Shirt Company, 538 Broadway, New York.

**Short Stories, Manuscripts Wanted**

Earn \$25 Weekly Spare Time writing for newspapers, magazines. Experience unnecessary; details free. Press Syndicate, 987 St. Louis, Mo.

Stories, Poems, Descriptive Articles, Plays, etc., are wanted for publication. Submit Mss. or write Literary Bureau, 105 Hannibal, Mo.

**Song Poems Wanted**

Write the words for a song. We compose music. Our Chief of Staff wrote many big song-hits. Submit your song-poem to us at once. New York Melody Corp., 4121 Romax Bldg., New York.

**Stammering**

St-Stu-t-t-tering and Stammering cured at home. Instruction booklet free. Walter McDonnell, 105 Potomac Bank Bldg., Washington, D. C.

**Stamps and Coins**

California Gold, quarter size, 27c; half-dollar size, 53c. Columbian nickel and catalogue, 10c. Norman Shultz, Box 146, Colorado Spring, Colo.

Stamps 100 All Different 3 cents. S. I. Quaker Stamp Company, Toledo, O.

158 Genuine Foreign Stamps. Mexico War Issues, Venezuela, Salvador and India Service, Guatemala, China, etc., only 5c. Finest approval sheets 50 to 60%. Agents Wanted. Big 72-p Lists Free. We buy stamps. Established 20 years. Hussman Stamp Co., Dept. 156, St. Louis, Mo.

**Printing**

Personal Stationery, 200 sheets, 100 envelopes, name address, printed in blue ink, \$1.00 postpaid. Beyond 3rd zone, \$1.15. 100 calling cards, 75c. National Print Shop, Box 1182, Dept. S.I., Washington, D. C.

**Technical Schools**

Chicago Technical College offers short, intensely practical courses in Drafting and Engineering—civil, mechanical, electrical, structural—Architecture, Building Construction, Plan Reading, etc. Courses fitted to your needs. No time wasted. Instructors are experts. Graduates in demand at big salaries. Opportunities for part-time work while studying. Day and evening classes. 21st year. Enter any time. No special preliminary training required. Low tuition—easy terms. Write for 52-page illustrated Blue Book, describing opportunities open to our graduates. Chicago Technical College, 24 Chicago Tech. Building, Chicago.

**Trade Schools**

\$10 to \$20 per day. Practical courses in Sign—Pictorial—Auto—Painting—Decorating—Graining—Marbling, Paperhanging—Low Cost—Catalog Free. Chicago Painting School, 132 E. Austin Ave., Chicago, Ill.

**Typewriters**

All standard makes, \$10 up. Fully guaranteed. Free trial. Write for complete illustrated lists. Northwestern Exchange, 121 N. Francisco Ave., Chicago.

**Wanted**

Detectives Earn Big Money. Work home or travel. Experience unnecessary. Particulars free. American Detective System, 1974 Broadway, N. Y.

# Be a Certificated Electrical Expert

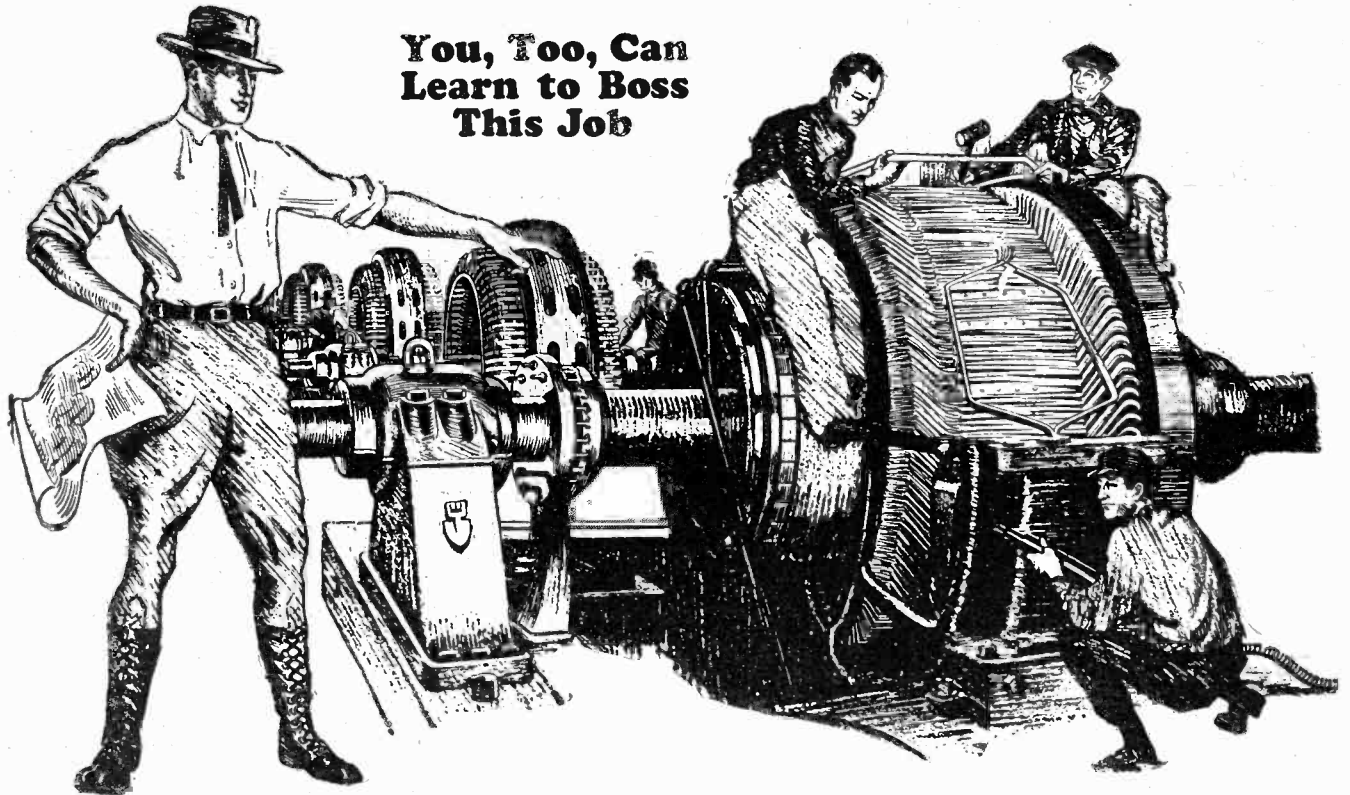

**You, Too, Can Learn to Boss This Job**

## EARN \$3500 to \$10000 a Year

Trained "Electrical Experts" are in great demand at the highest salaries, and the opportunities for advancement and a big success in this line are the greatest ever known. "Electrical Experts" earn \$70 to \$200 a week.

Fit yourself for one of these big paying positions. In my twenty years of Electrical Engineering I have gathered some wonderful and interesting facts about this great industry — "Vital Facts." I will send them to you free.

**Learn at Home to Earn \$12.00 to \$30.00 a Day**

Today even the ordinary Electrician — the "screw driver" kind — is making money — big money. But it's the trained man — the man who knows the whys and wherefores of Electricity — the "Electrical Expert" — who is picked out to "boss" ordinary Electricians — to boss Big Jobs — the jobs that pay. You, too, can learn to fill one of these jobs — spare-time only is needed. Be an "Electrical Expert" — Earn \$70 to \$200 a week.

**Age or Lack of Experience No Drawback**

You don't have to be a College Man; you don't have to be a High School graduate. If you can read and write English, my course will make you a big success. It is

the most simple, thorough, and successful Electrical Course in existence, and offers every man, regardless of age, education, or previous experience, the chance to become, in a very short time, an "Electrical Expert," able to make from \$70 to \$200 a week.

Materials and Measuring Instruments absolutely FREE. I also furnish them with all supplies, including examination paper, and many other things that other schools don't furnish. You do PRACTICAL work — AT HOME with this Outfit. You start right in after the first few lessons to WORK AT YOUR PROFESSION in a practical way.

**Some Features of My Course That Make SUCCESS Certain**

1. Practical Money-Making Instruction — no useless, high-sounding theory.
2. Free Electrical Outfit. — Finest outfit ever sent out for home experiment and practical use.
3. Free Employment Service. (Helps you get a good job.)
4. Free Consulting Service. (No chance to get stuck on anything, while studying or afterward.)
5. Free Engineering Magazine.
6. Free use of my Electrical Laboratory.
7. Extra Courses Free — Radio — Electrical Drafting.
8. Spare Time Work — Special earn-while-you-learn lessons.
9. Reduced prices on all Electrical Supplies.
10. Cash Refund Guarantee Bond.

These features are all explained in my big Free Book.

**I Give You a Real Training**

As Chief Engineer of the Chicago Engineering Works, I know exactly the kind of training a man needs to get the best positions at the highest salaries. Hundreds of my students are now earning \$3,500 to \$10,000 a year. Many are successful ELECTRICAL CONTRACTORS.

**Your Satisfaction Guaranteed**

So sure am I that you can learn Electricity — so sure am I that after studying with me, you too, can get into the "big money" class in electrical work, that I will guarantee under bond to return every single penny paid me in tuition if, when you have finished my course, you are not satisfied it was the best investment you ever made.

**FREE — Electrical Working Outfit — FREE**

I give each student a Splendid Outfit of Electrical Tools,

**Get Started Now — Mail Coupon**

I want to send you the "Vital Facts" of the Electrical Industry including my Electrical Book, Proof Lessons, and a sample of my guarantee bond all FREE. These cost you nothing and you'll enjoy them. Make the start today for a bright future in Electricity. Send in the coupon — NOW.

**L. L. COOKE, Chief Engineer  
Chicago Engineering Works  
Dept. 526 2150 Lawrence Ave., Chicago**

**Use this Free Outfit Coupon!**

L. L. COOKE, Chief Engineer,  
Chicago Engineering Works, Dept. 526,  
2150 Lawrence Ave., Chicago, Ill.

Dear Sir: — Send at once the "Vital Facts" containing Sample Lessons, your Big Book, and full particulars of your Free Outfit and Home Study Course — all fully prepaid, without obligation on my part.

Name.....  
Address.....  
City and State.....  
Occupation..... Age.....

**The "Cooke" Trained Man is the "Big Pay" Man**

# CARPENTRY SELF TAUGHT!!



## Spare Time Reading Teaches Profitable Trade—Solves Problems

Over a hundred million dollars worth of building is being done every month! The biggest building boom in the history of the country. Men that know carpentry are in great demand. The quickest way to learn carpentry and get your share of the building money is by spare time reading of Audel's Guides. Learn the fundamentals, then keep the volume you need handy as a practical working guide. Carpenters everywhere will tell you that Audel's New Guides are a Good Set.

### Condensed Contents of Audel's New Guides

- Guide No. 1—Over 431 pages—1200 illustrations**
- How to know the different kinds of wood.
  - How to use the different kinds of wood.
  - Complete detailed information on nails and screws.
  - How circular and band saws are handled.
  - How to use the steel square.
  - How to sharpen tools.
  - How to file and set saws.
  - How to make wood joints.
  - Complete information regarding joints and joinery.
  - How to build furniture.
  - How to make a work bench.
  - How to make a mitre box.
  - How to make a mitre shooting board.
  - How to plumb and level work.
  - How to use the chalk line.
  - How to lay out work.
  - How to use rules and scales.
  - How to use all of the carpenter's tools, with over 900 illustrations showing specifically how.
- Guide No. 2—Over 455 pages—400 illustrations**
- How to understand carpenter's arithmetic.
  - How to understand geometry.
  - How to understand trigonometry.
  - How to solve mensuration problems.
  - How to estimate the strength of timbers.
  - How to proportion beams.
  - How to use drawing instruments.
  - How to read plans.
  - How to survey.
  - How to draw up specifications.
  - How to estimate cost.
  - How to build houses, barns, garages, bungalows, etc.
- Guide No. 3—Over 255 pages—400 illustrations**
- How to excavate foundations.
  - How to build foundations.
  - How to make water-proof.
  - How to erect post foundations.
  - How to build forms for concrete.
  - How to proportion foundation footings.
  - How to frame houses.
  - How to set girders and sills.
  - How to frame joists.
  - How to construct a well hole.
  - How to frame a studding.
  - How to frame corner posts.
  - How to lay out and cut braces.
  - How to attach lath to corner posts.
  - How to frame temporary and permanent braces.
  - How to frame girts and ribbands.
  - How to set window frames.
  - How to frame partitions.
  - How to distinguish various types of roofs.
  - How to use the settings 12, 13 and 17 on the steel square.
  - How to lay out mitre cuts.
  - How to use tangents, and full detailed information covering sky lights, scaffold and hoisting.
- Guide No. 4—Over 448 pages—400 illustrations**
- How to put on wood, fibre and metal shingles.
  - How to lay gravel roofs.
  - How to lay tin roofs.
  - How to hang doors.
  - How to frame windows.
  - How to put on siding.
  - How to put on exterior trim.
  - How to do cornice work.
  - How to build stairs.
  - How to lath.
  - How to lay floors.
  - How to put on interior trim.
  - How to paint.
  - How to give first aid to the injured.

## New Ideas - Modern Methods - Short Cuts

This course "Audel's Guides for Carpenters and Builders" consists of 4 handy volumes of over 1500 pages with thoroughly illustrated charts, diagrams, graphs, pictures with calculations for every job from making the excavation to constructing the entire building. You will find these new Guides most complete and comprehensive in addition to being both timely and practical. There are 3700 actual examples of efficient construction work with new methods, ideas, solutions, plans, systems,

short cuts, time and labor saving suggestions, new ways that cover the entire theory and practice of the subject illustrated by sketches and forms all specific and practical. Audel's Guides give you the short cut, professional information you want. No need to guess or take chances. Every day you have before you in this set the exact, practical, useful information that will help you with every job that comes up in your daily work.

## Thousands Say Guides Are Carpenter's Best Friend

**"Reasonable Price"**  
I find the Guides very satisfactory. The knowledge in them is much greater than I anticipated. A very convenient size and price is so reasonable that every carpenter should possess a set. —Ralph M. Collemer, Lowell, Mass.

**"Valuable for Beginners of Old Timers"**  
I have looked over my Audel Guides and find a wealth of information. Their size makes them very handy to carry right onto the job. I have put my books in my tool kit and have them

for ready reference. The arrangement of subjects and the simple way it is explained make the books very valuable for the beginner. The rules and formulas are mighty handy for the old timers. —Ross Smith, Sommers Point, N. J.

**"Good For Professional Carpenters"**  
It is the most handy reference work that I ever came in contact with. It is the very thing that the building mechanic needs every day for reference. I wish to state further there is not a

foreman or superintendent who can afford to be without this valuable work. I wish you unbounded success. —George H. Watson, 136 Munson St., Long Island City, N. Y.

**"Guides Save Hard Knocks"**  
The Guides are truly wonderful and should be in the hands of all young carpenters as well as a lot of the older heads. If I had such information 20 years ago they would have saved me many a hard knock and also sleepless nights trying to

figure out the next day's work. —G. M. McJohnston, R. R. 1, Hammond, Ind.

**"Save Money"**  
The Guides have met with my complete satisfaction. Anyone expecting to build a home can well save \$150 or more by using the information given in your books. W. E. Frantz, Box 77, Tuscarawas, Ohio.

**"Good For Amateurs"**  
The books are surely worth more than the purchase price; especially as they serve as a guide to the non-

professional like myself who is trying to build himself a home at the least expense. —Otto F. Schulze, P. O. Box 143, Westmont, Ill.

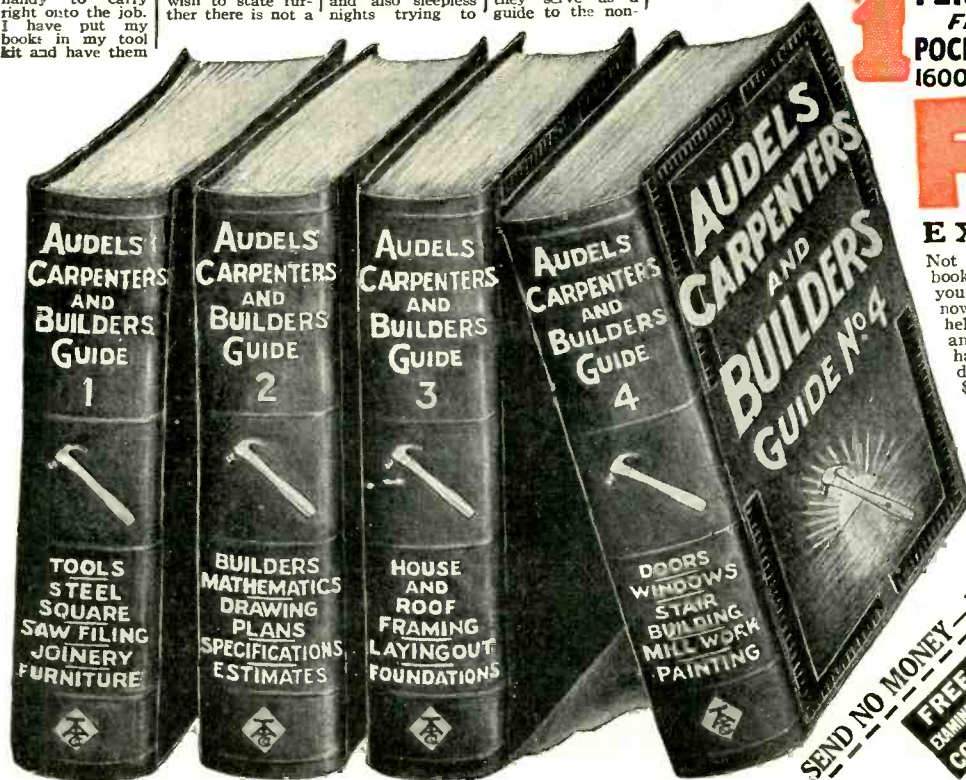

**\$1 PER MONTH—ENTIRE SET \$6**  
FREE EXAMINATION  
POCKET SIZE—FLEXIBLE COVERS  
1600 PAGES—3700 ILLUSTRATIONS

**FREE EXAMINATION**

Not a cent to pay until you see the books. No obligation to pay until you are satisfied. Send coupon now—today and get this fine, helpful new set for Carpenters and Builders. After you have looked them over 5 days send only \$1, then \$1 a month until \$6 is paid—if you want to keep them.

**SEND NO MONEY—NOTHING TO POSTMAN—MAIL COUPON NOW!**  
THEO. AUDEL & CO., 72 Fifth Avenue, New York City.  
Please submit me for approval and free examination: —  
AUDEL'S CARPENTERS AND BUILDERS GUIDES. Ship at once, prepaid, the 4 numbers. If satisfactory I agree to send you \$1 with the first five days and to further mail you \$1 monthly until \$6 is paid.

NAME.....  
ADDRESS.....  
OCCUPATION.....  
EMPLOYED BY.....  
S-I-SEPT.

*Your dealer has something  
really new and unusual*

## MAGNAVOX M4

CALL at your dealer's today and ask him to show you a Magnavox M4 Reproducer.

Try out the instrument critically; satisfy yourself that its clear tone and natural volume are sustained throughout the entire musical range; examine each essential detail of convenient size, handsome finish and sturdy construction; note that its operation requires no battery.

M4 is a definite contribution to the radio art—and one particularly welcome to the moderate income.

### There is a Magnavox for every receiving set

#### Reproducers

- M4—the latest Magnavox achievement: requires no battery \$25.00
- M1—also constructed on the semi-dynamic principle, requiring no battery \$30.00
- R3—famous electro-dynamic type: new model with Volume Control \$35.00
- R2—same as R3 but larger size: new model with Volume Control. \$50.00

#### Combination Sets

- A1-R and A2-R—the only instruments combining electro-dynamic Reproducer and Power Amplifier in one unit \$59.00, \$85.00

#### Power Amplifiers

- A1, AC-2-C, AC-3-C—the most efficient audio-frequency Amplifiers: one, two & three stage \$27.50 to \$60.00

To obtain the fullest enjoyment from your receiving set, equip it with the Magnavox—for sale at good dealers everywhere.

**THE MAGNAVOX CO.**  
OAKLAND, CALIFORNIA  
New York Office:  
350 WEST 31st STREET

Canadian Distributors:  
Perkins Electric Limited, Toronto.  
Montreal, Winnipeg

8R

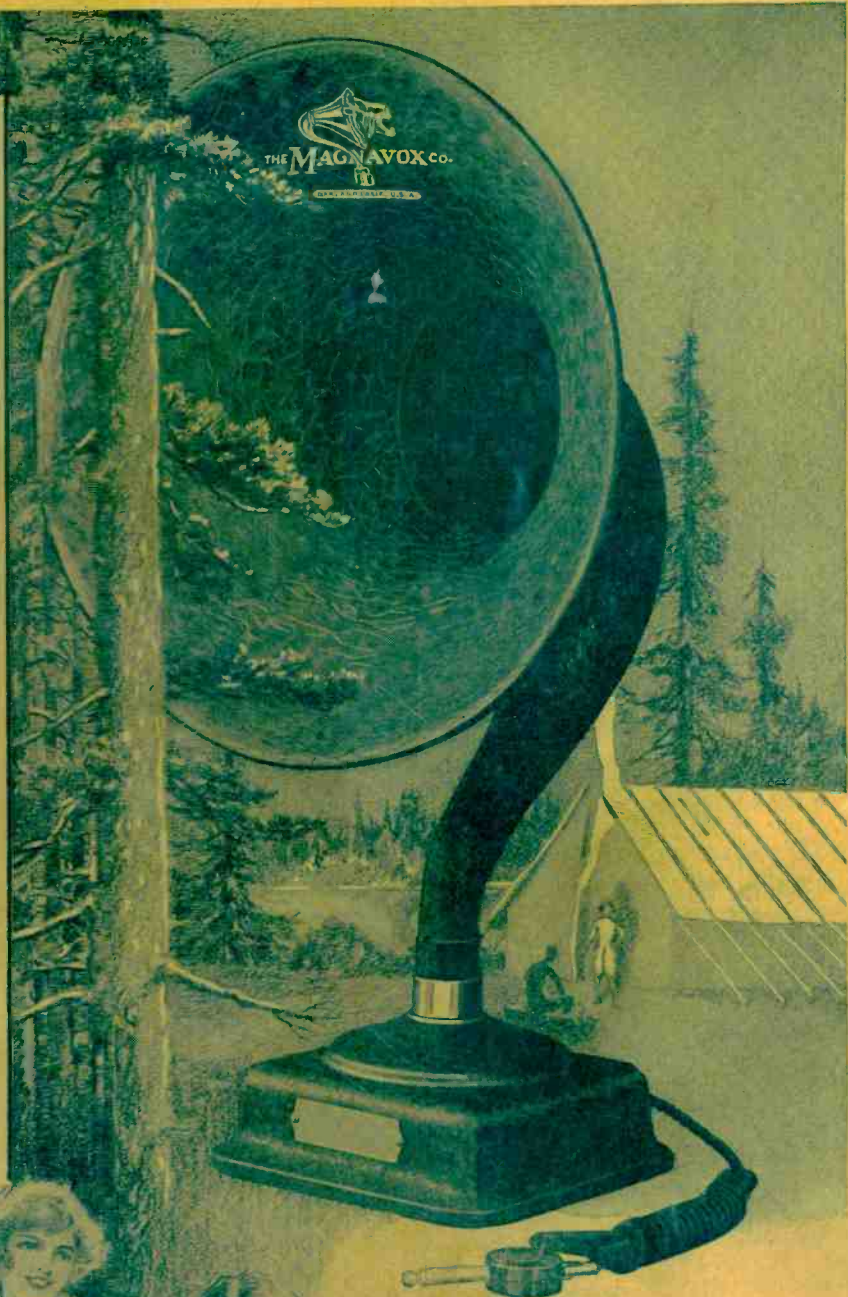

M4  
\$25.00

# MAGNAVOX

MAGNAVOX Radio

